



US00D367840S

# United States Patent [19]

[11] Patent Number: **Des. 367,840**

VanHoose et al.

[45] Date of Patent: **\*\*Mar. 12, 1996**

[54] **VEHICLE CARGO AREA PROTECTIVE DEVICE**

*Assistant Examiner*—Cathron B. Matta  
*Attorney, Agent, or Firm*—Robert Treece

[75] Inventors: **Jeffery J. VanHoose**, Edmond; **James M. Clanton**, Ardmore, both of Okla.

[57] **CLAIM**

The ornamental design for a vehicle cargo area protective device, as shown and described.

[73] Assignee: **Vehicle Protection, Inc.**, Edmond, Okla.

**DESCRIPTION**

[\*\*] Term: **14 Years**

FIG. 1 is a front perspective view of a vehicle cargo area protective device;

[21] Appl. No.: **28,924**

FIG. 2 is a cutaway view of an inside front corner of the vehicle cargo area protective device of FIG. 1;

[22] Filed: **Sep. 26, 1994**

FIG. 3 is a top plan view of the vehicle cargo area protective device of FIG. 1;

[52] U.S. Cl. .... **D12/221**

[58] Field of Search ..... D12/221; D9/502; D32/55; 296/39.1, 39.2, 39.3

FIG. 4 is a left elevational view of the vehicle cargo area protective device of FIG. 1;

[56] **References Cited**

**U.S. PATENT DOCUMENTS**

D. 249,494	9/1978	Lambitz	.....	D12/221
D. 271,009	10/1983	Fishler	.....	D12/221 X
D. 293,226	12/1987	Whitson	.....	D12/221 X
D. 298,112	10/1988	Hall	.....	D12/221
D. 333,112	2/1993	Diaco et al.	.....	D12/221
D. 336,062	6/1993	Austin	.....	D12/221
4,991,899	2/1991	Scott	.....	296/39.2
5,154,478	10/1992	Erickson et al.	.....	296/39.2

FIG. 5 is a bottom plan view of the vehicle cargo area protective device of FIG. 1;

FIG. 6 is a right elevational view of the vehicle cargo area protective device of FIG. 1;

FIG. 7 is a front elevational view of the vehicle cargo area protective device of FIG. 1;

FIG. 8 is a rear elevational view of the vehicle cargo area protective device of FIG. 1; and,

FIG. 9 is a cross sectional view of the vehicle cargo area protective device along line 9—9 of FIG. 3.

*Primary Examiner*—Alan P. Douglas

**1 Claim, 4 Drawing Sheets**

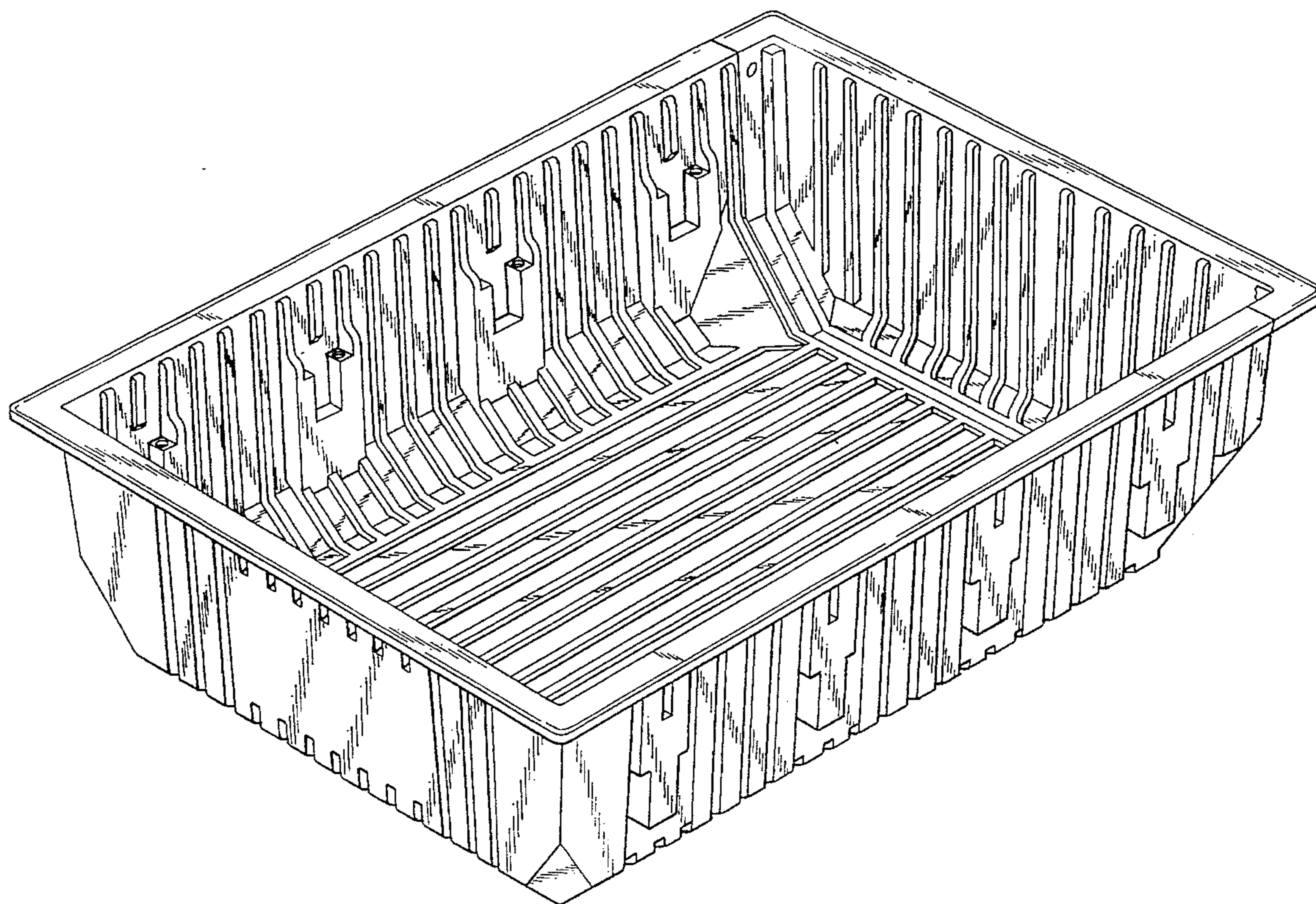

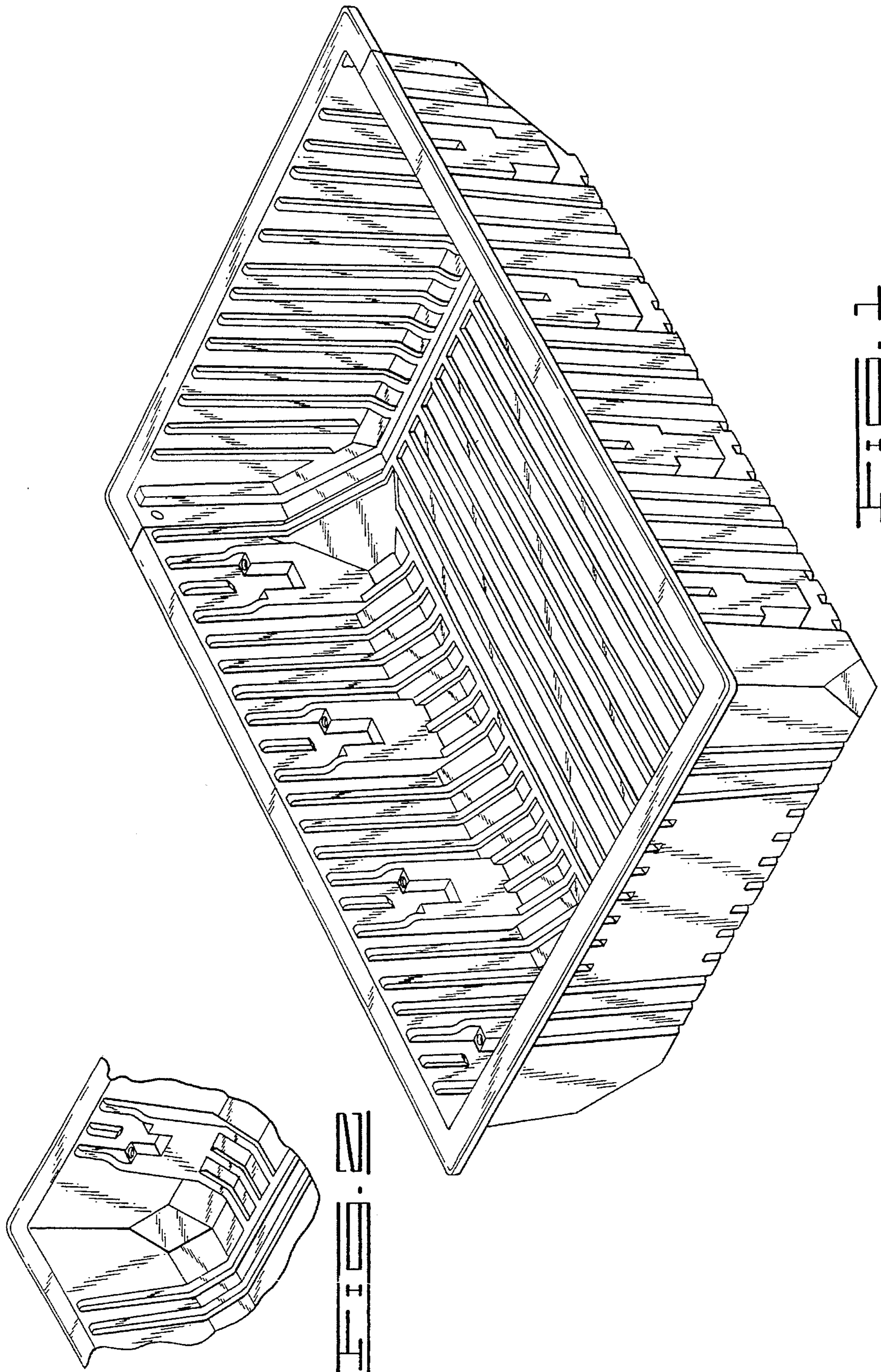

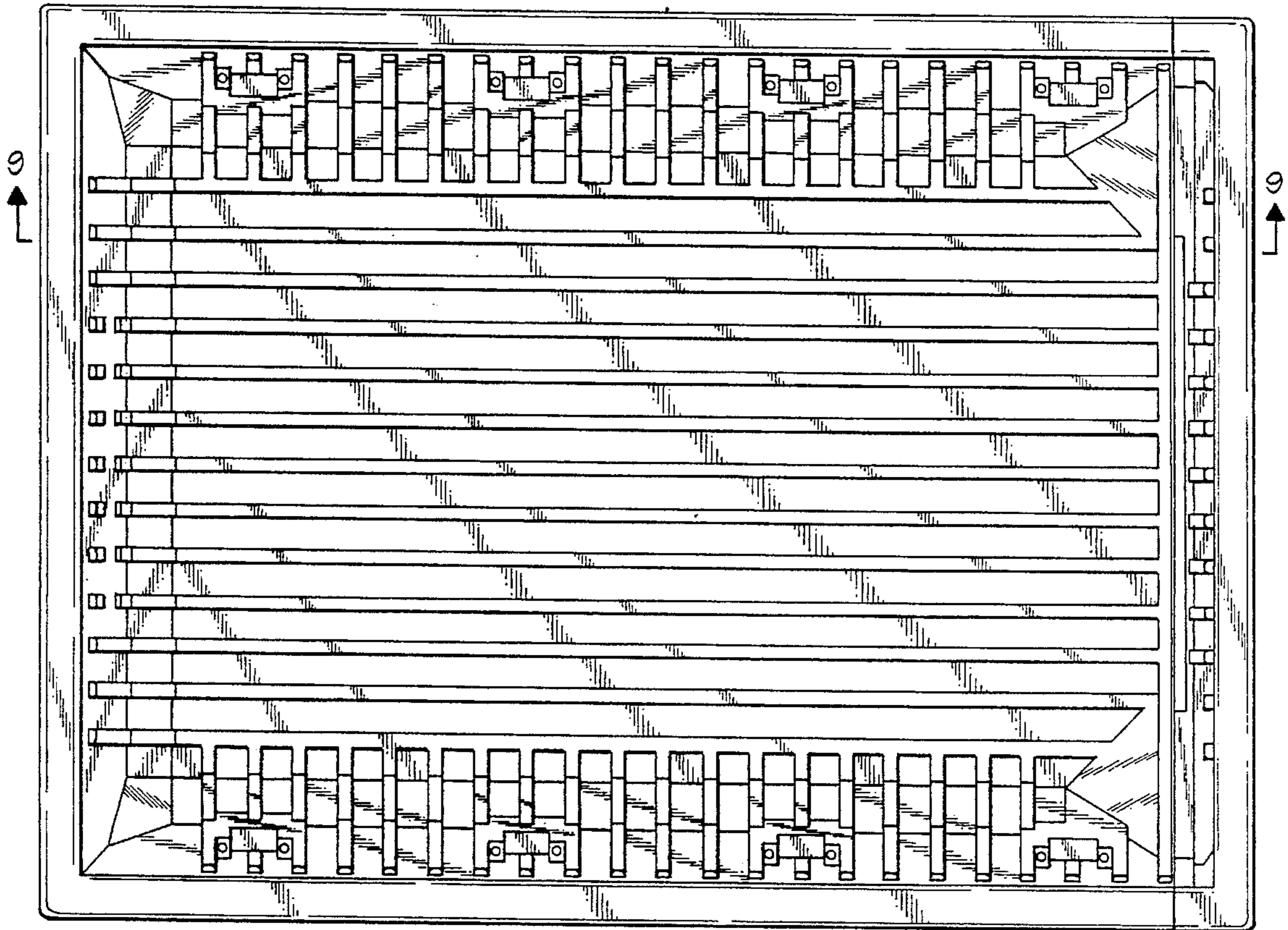

FIG. 3

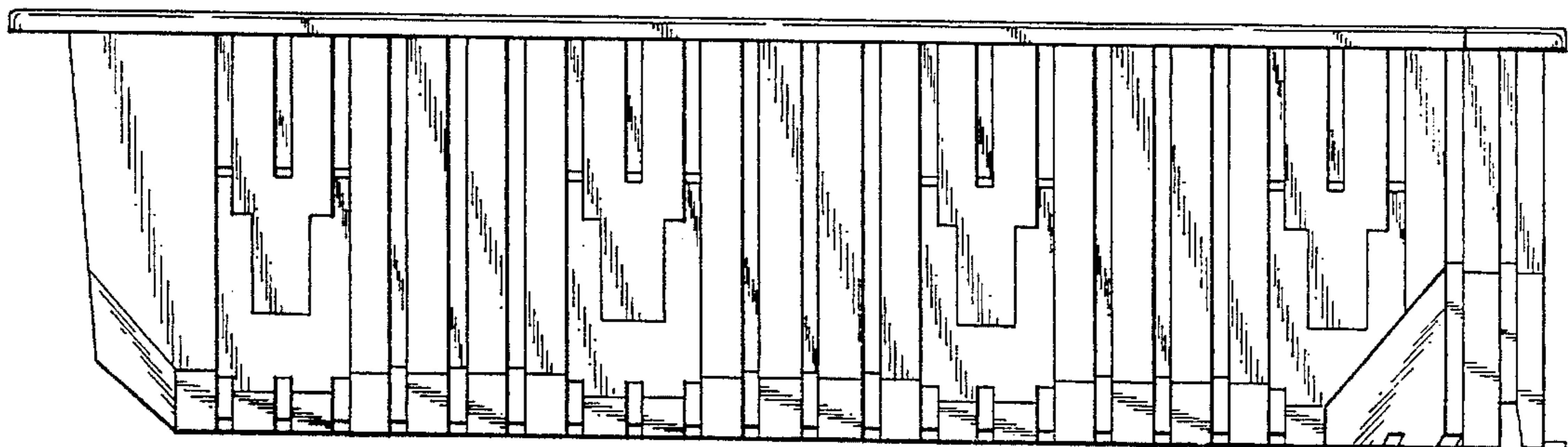
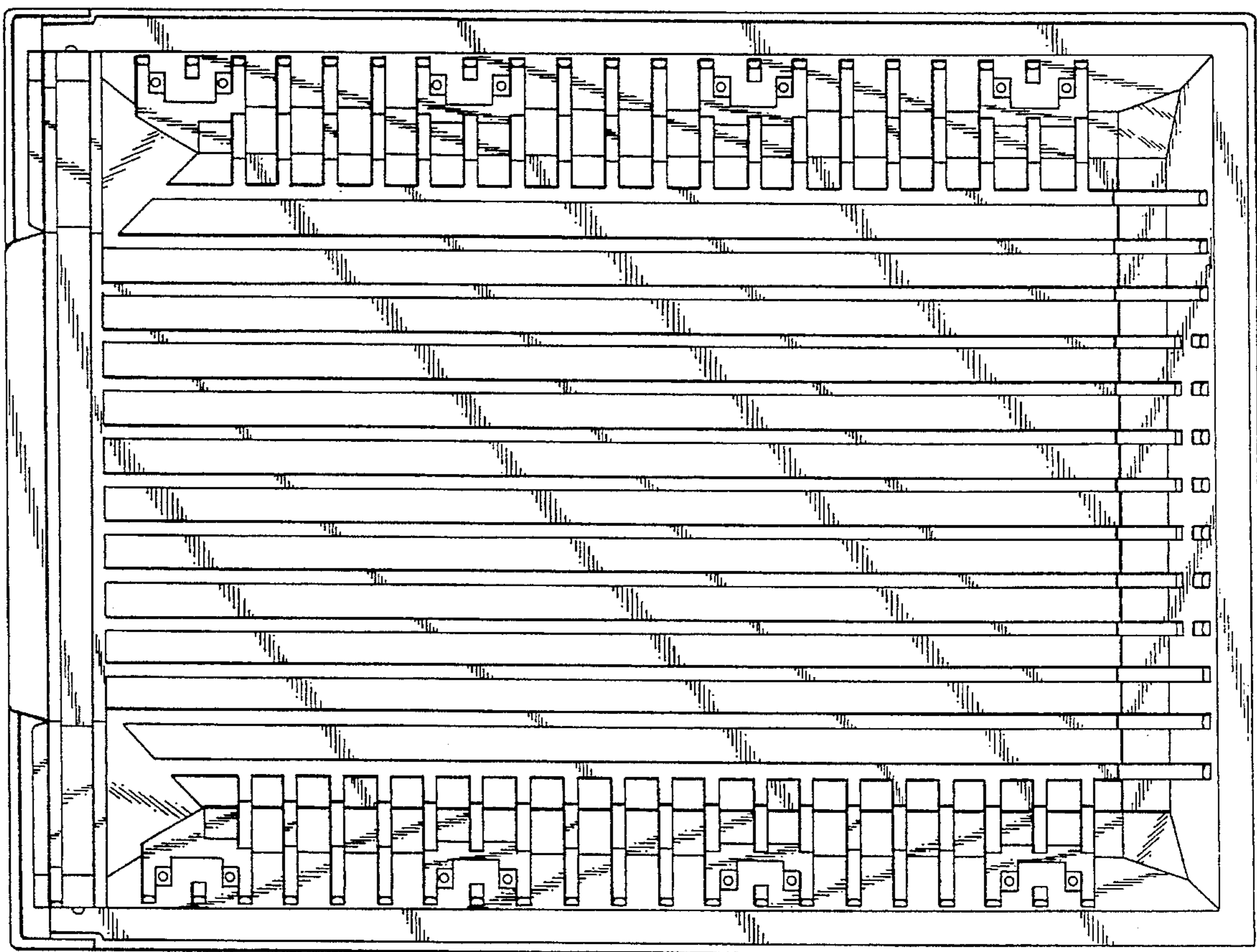

FIG. 4



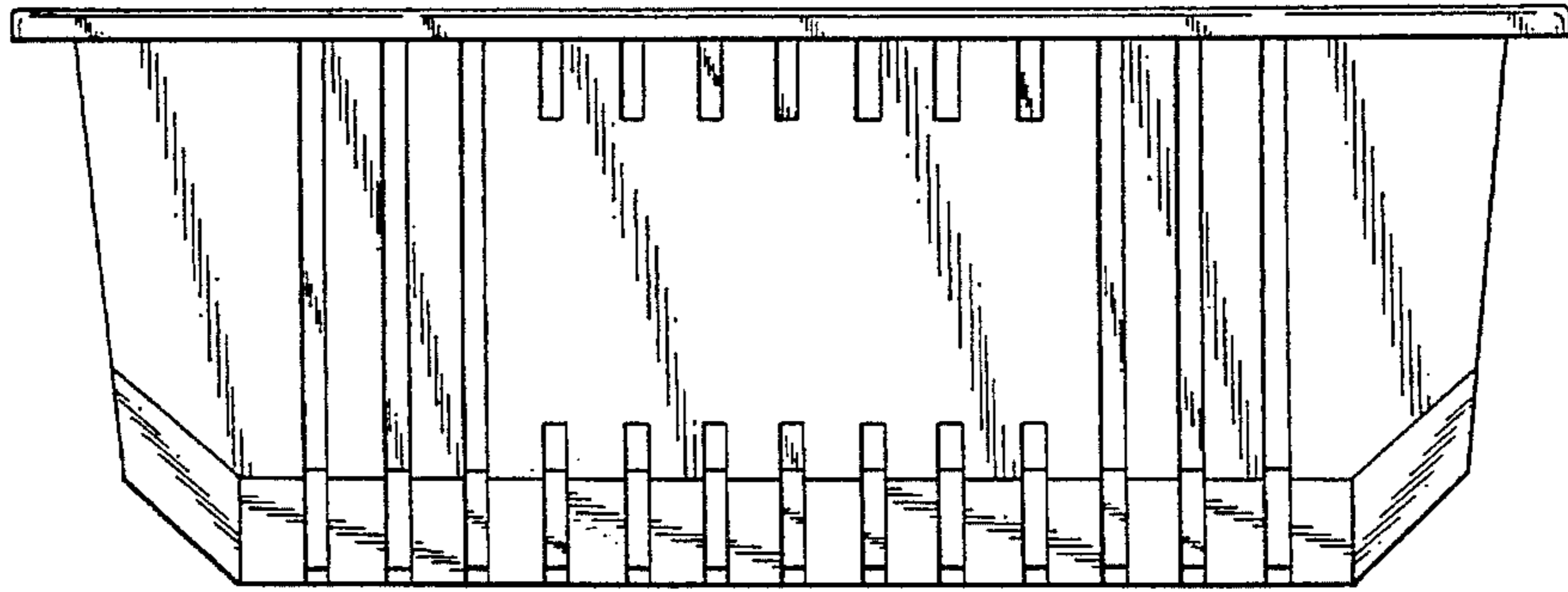

FIG. 2

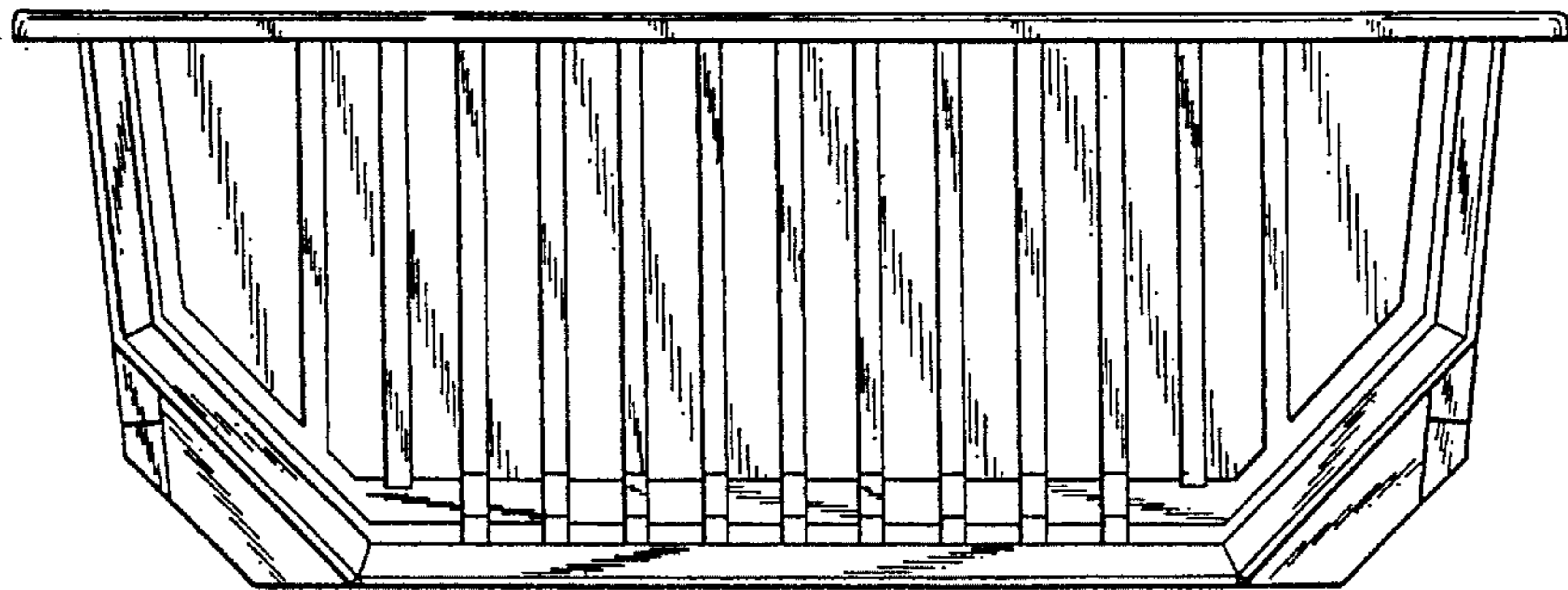

FIG. 3

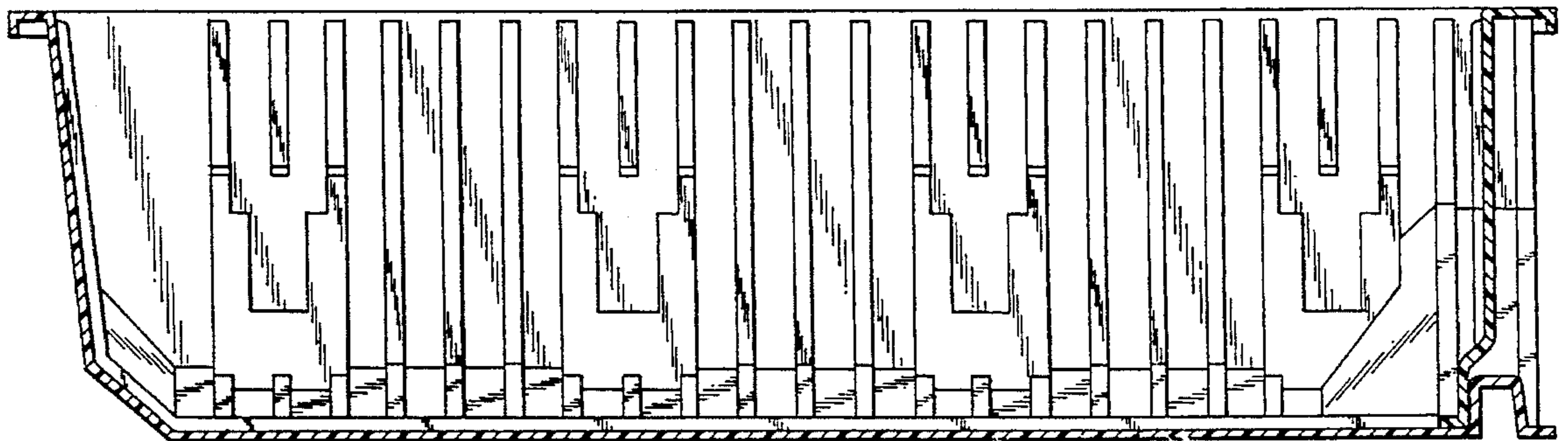

FIG. 4