



US00D367678S

United States Patent [19]
Hart

[11] **Patent Number:** **Des. 367,678**
[45] **Date of Patent:** ****Mar. 5, 1996**

[54] **ADVERTISING DISPLAY FOR STACKED PRODUCTS**

[76] Inventor: **Kevin A. Hart**, Vent House, Charxing, Ashford, Kent TN27 0HH, England

[**] Term: **14 Years**

[21] Appl. No.: **32,382**

[22] Filed: **Nov. 18, 1994**

[30] **Foreign Application Priority Data**

Sep. 17, 1993 [GB] United Kingdom 2033955

[52] U.S. Cl. **D20/40**

[58] **Field of Search** D20/10, 37, 39, D20/40, 42; 40/1, 124, 124.1, 124.4, 584, 624; D6/396, 329

[56] **References Cited**

U.S. PATENT DOCUMENTS

- Re. 32,668 5/1988 Smith .
- D. 243,560 3/1977 Vogelheim .
- D. 306,614 3/1990 Kodner et al. .
- D. 324,701 3/1992 Capps D20/19
- 1,938,919 12/1933 Marsh .

- 1,984,559 12/1934 Wilcox .
- 2,108,096 2/1938 Barsi .
- 2,801,754 8/1957 Dorfman .
- 3,380,181 4/1968 Karel .
- 4,582,195 4/1986 Carstens .
- 5,259,578 11/1993 Jones et al. .

Primary Examiner—A. Hugo Word
Assistant Examiner—Marcus Jackson
Attorney, Agent, or Firm—William Brinks Hofer Gilson & Lione

[57] **CLAIM**

The ornamental design for an advertising display for stacked products, as shown and described.

DESCRIPTION

FIG. 1 is a perspective view of an advertising display for stacked products;
FIG. 2 is a front elevational view thereof;
FIG. 3 is a right side elevational view thereof, the left side elevational view being a mirror image thereof;
FIG. 4 is a back elevational view thereof;
FIG. 5 is a top plan view thereof; and,
FIG. 6 is a bottom plan view thereof.

1 Claim, 2 Drawing Sheets

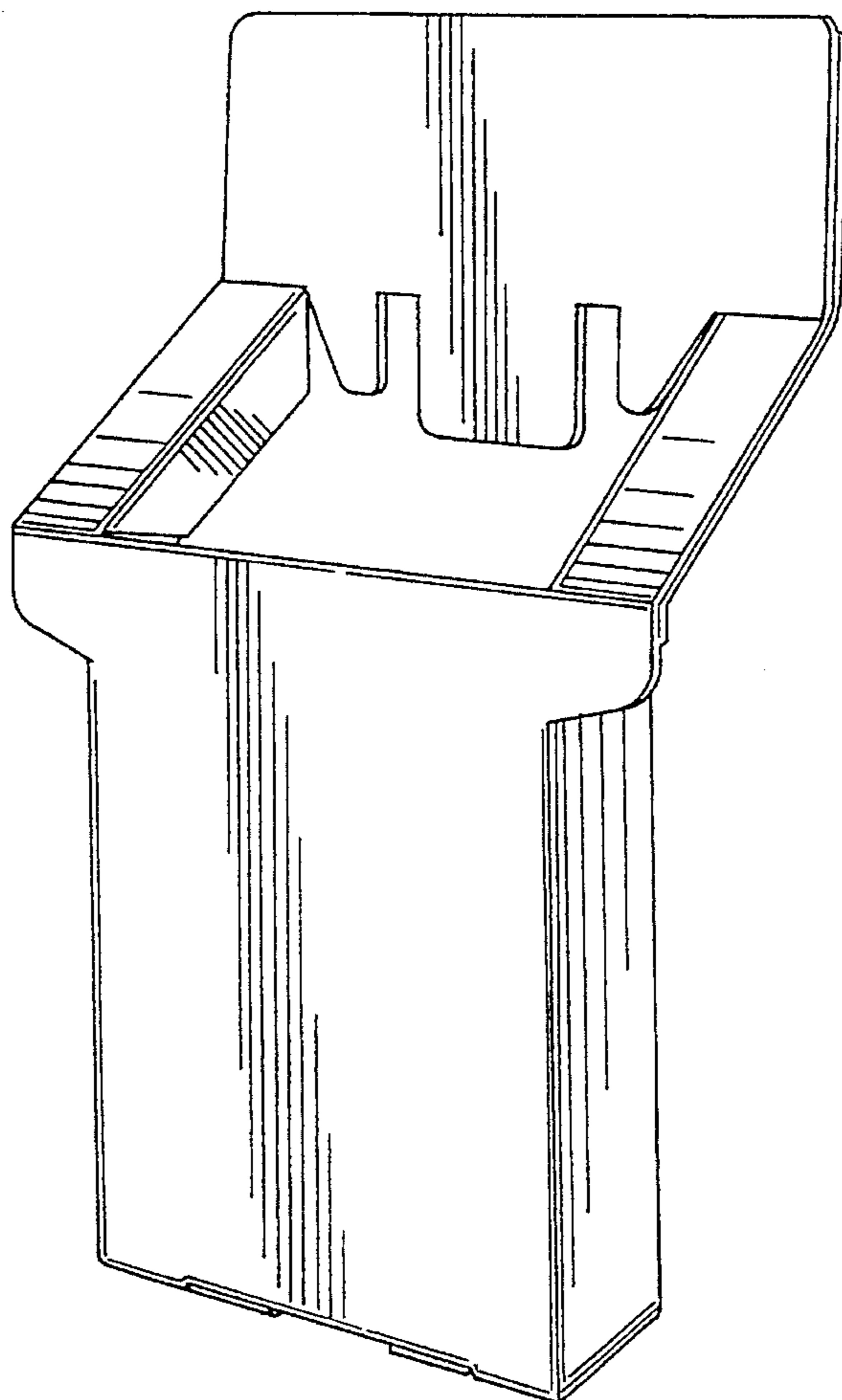

FIG. 1

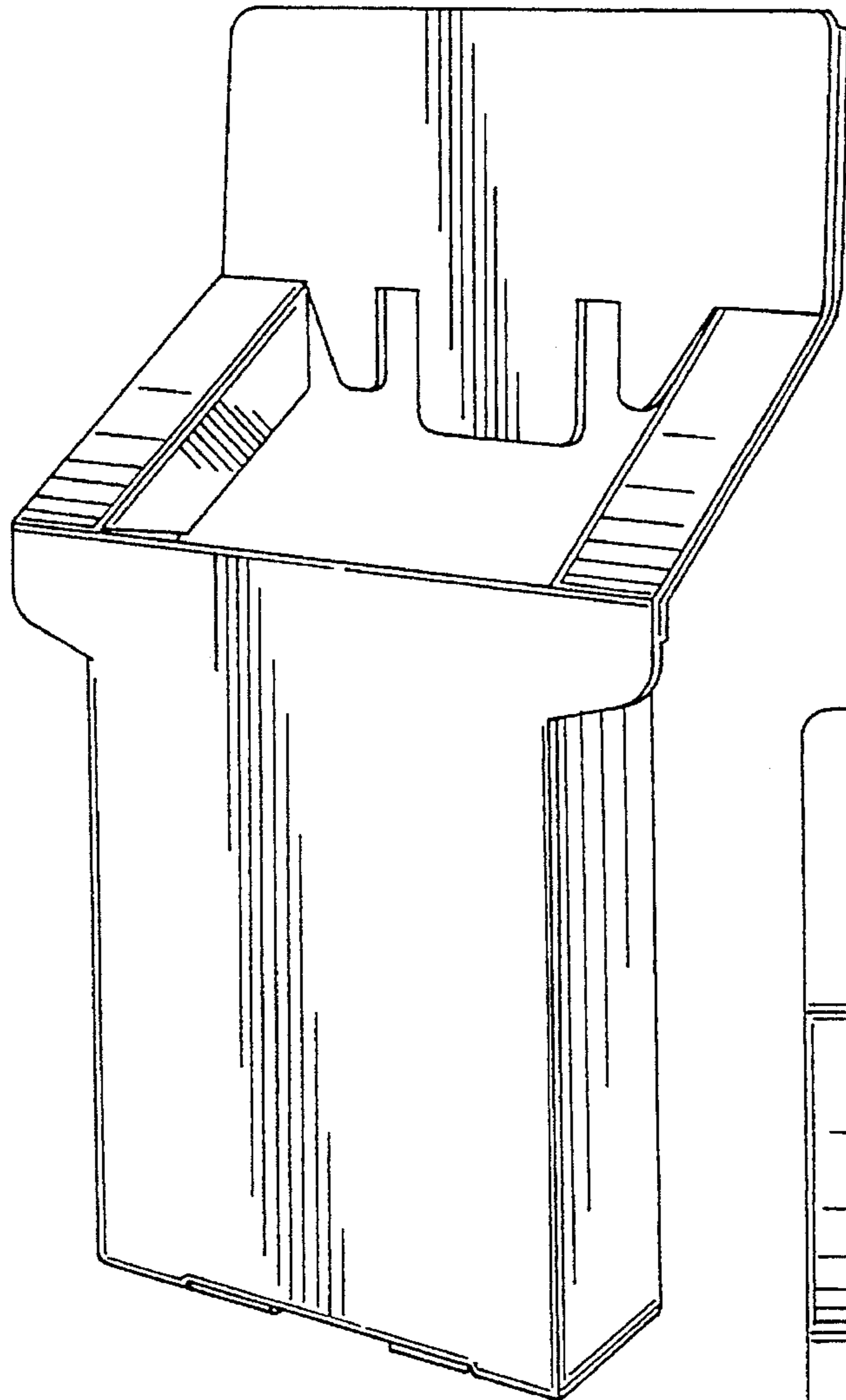

FIG. 2

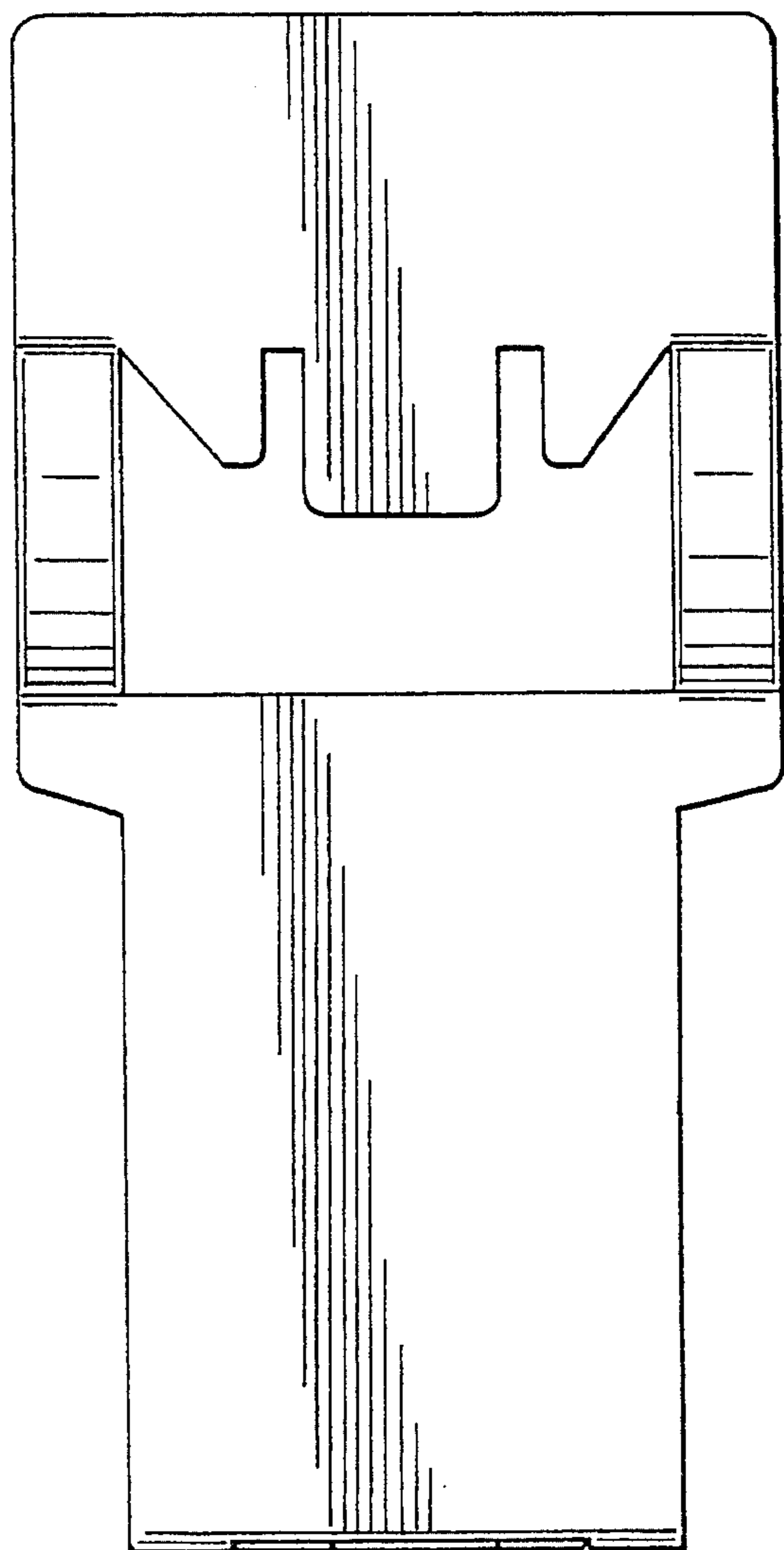

FIG. 3

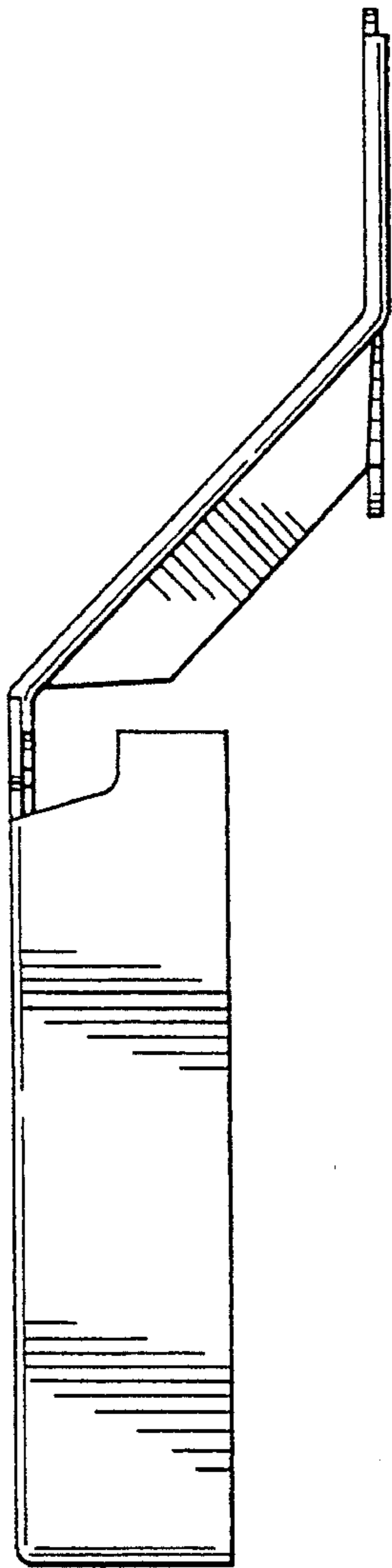

FIG. 4

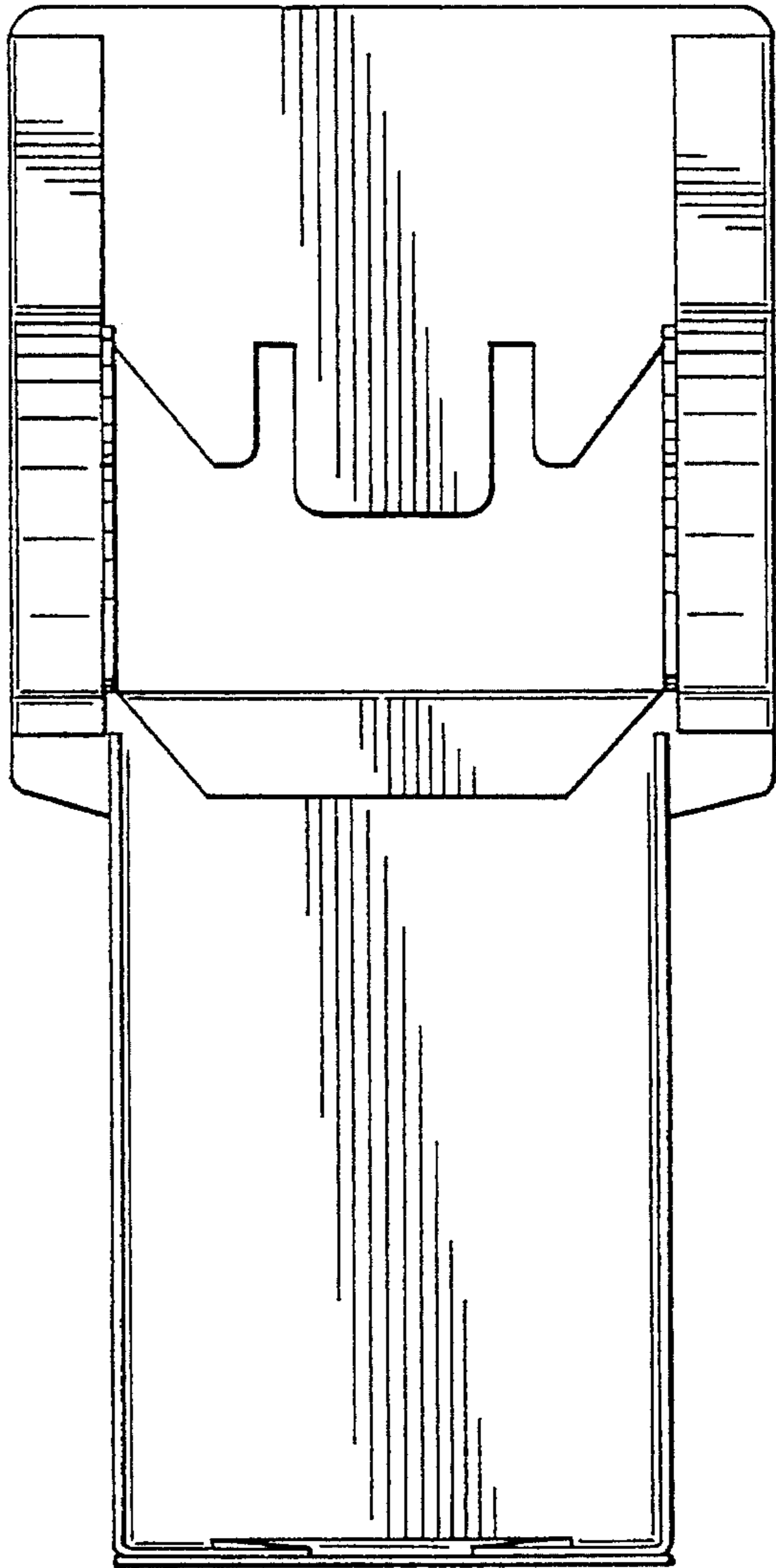

FIG. 5

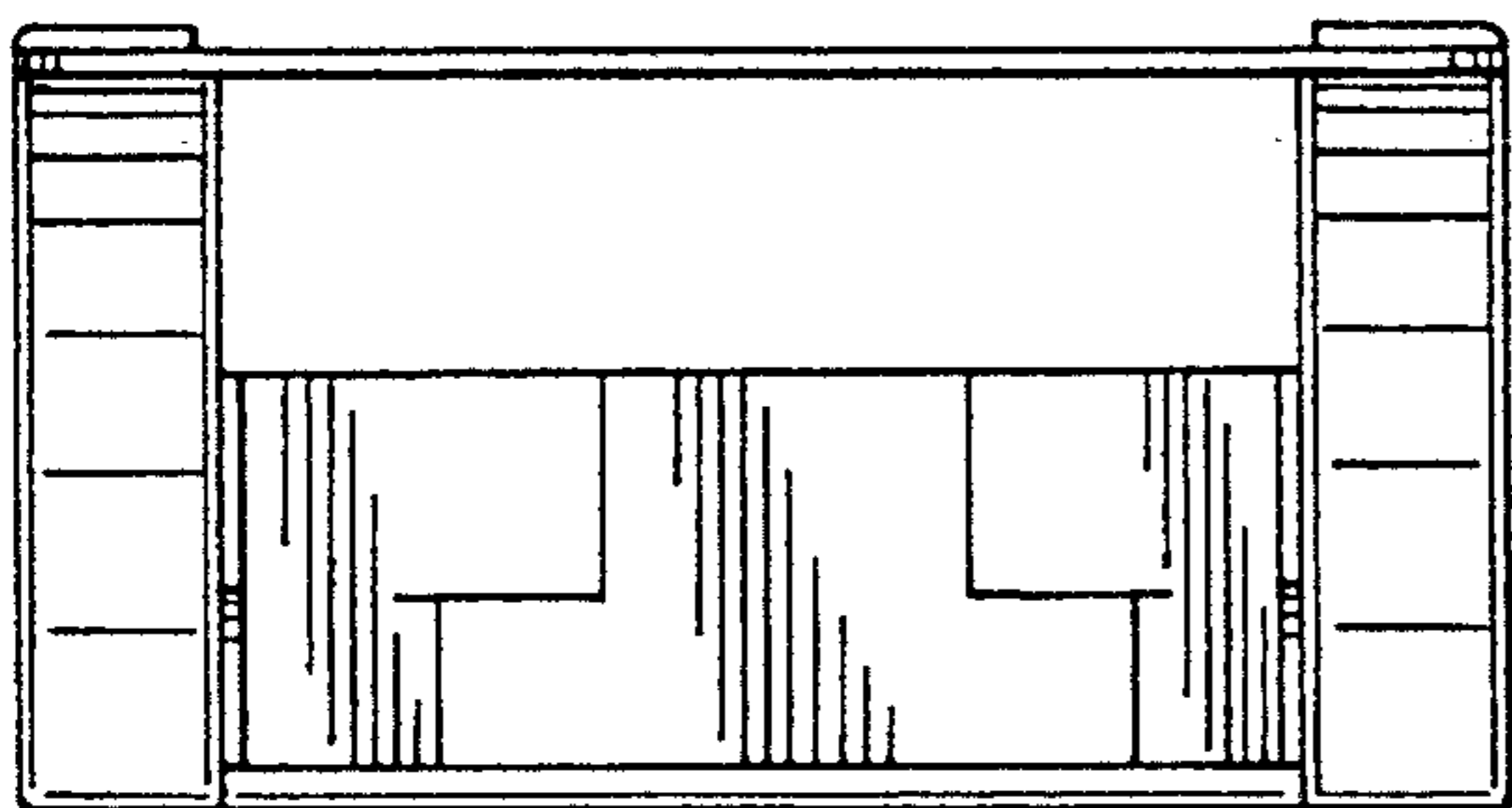

FIG. 6

