



US00D367463S

United States Patent [19]
Reiland

[11] **Patent Number: Des. 367,463**

[45] **Date of Patent: **Feb. 27, 1996**

[54] **EXTENDED TOPPER-SHELL FOR PICK-UP TRUCK BED**

[76] Inventor: **Peter M. Reiland**, Rte. 5, Box 5286, Athens, Tex. 75751

[**] Term: **14 Years**

[21] Appl. No.: **27,308**

[22] Filed: **Aug. 18, 1994**

[52] U.S. Cl. **D12/404**

[58] Field of Search D12/401, 403-405; 296/10, 99.1, 100, 102, 156, 164

[56] **References Cited**

U.S. PATENT DOCUMENTS

- D. 271,757 12/1983 Miller D12/404
- D. 325,551 4/1992 Quiniones D12/404
- D. 328,049 7/1992 Sturtevant D12/404

Primary Examiner—A. Hugo Word

Assistant Examiner—Lavone D. Tabor
Attorney, Agent, or Firm—Crutsinger & Booth

[57] **CLAIM**

The ornamental design for an extended topper-shell for pick-up truck bed, as shown and described.

DESCRIPTION

FIG. 1 is a perspective view from the left rear of the extended truck bed topper showing my design; FIG. 2 is a rear elevation view thereof; FIG. 3 is a right side elevation view, the left side being a mirror image of the right side; FIG. 4 is a front elevation view thereof; FIG. 5 is a top plan view thereof; FIG. 6 is a bottom plan view thereof; and, FIG. 7 is a perspective view from the left rear thereof with the access hatch open.

The broken lines shown in FIGS. 1-4 and 7 are for illustrative purposes only and form no part of the claimed design.

1 Claim, 4 Drawing Sheets

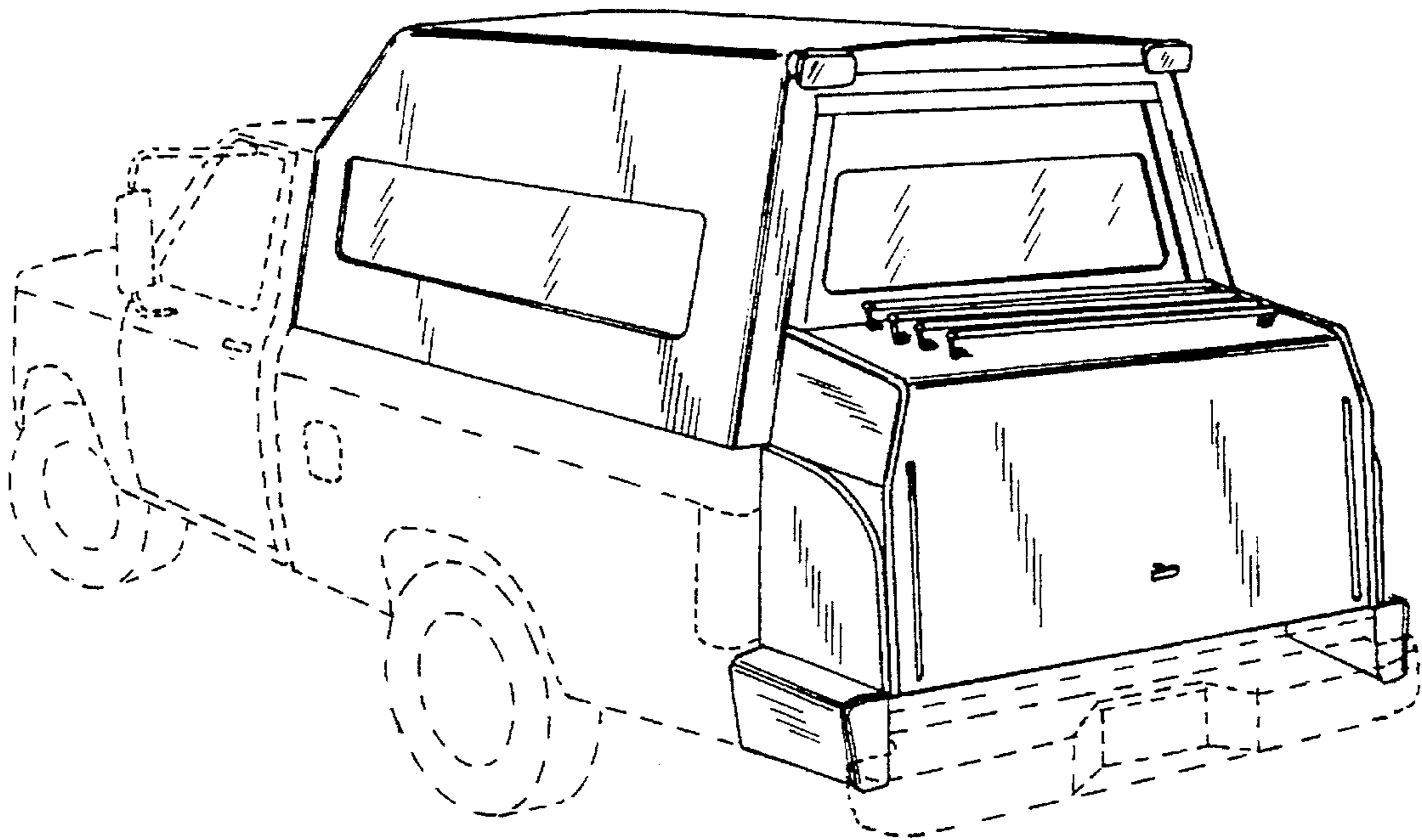

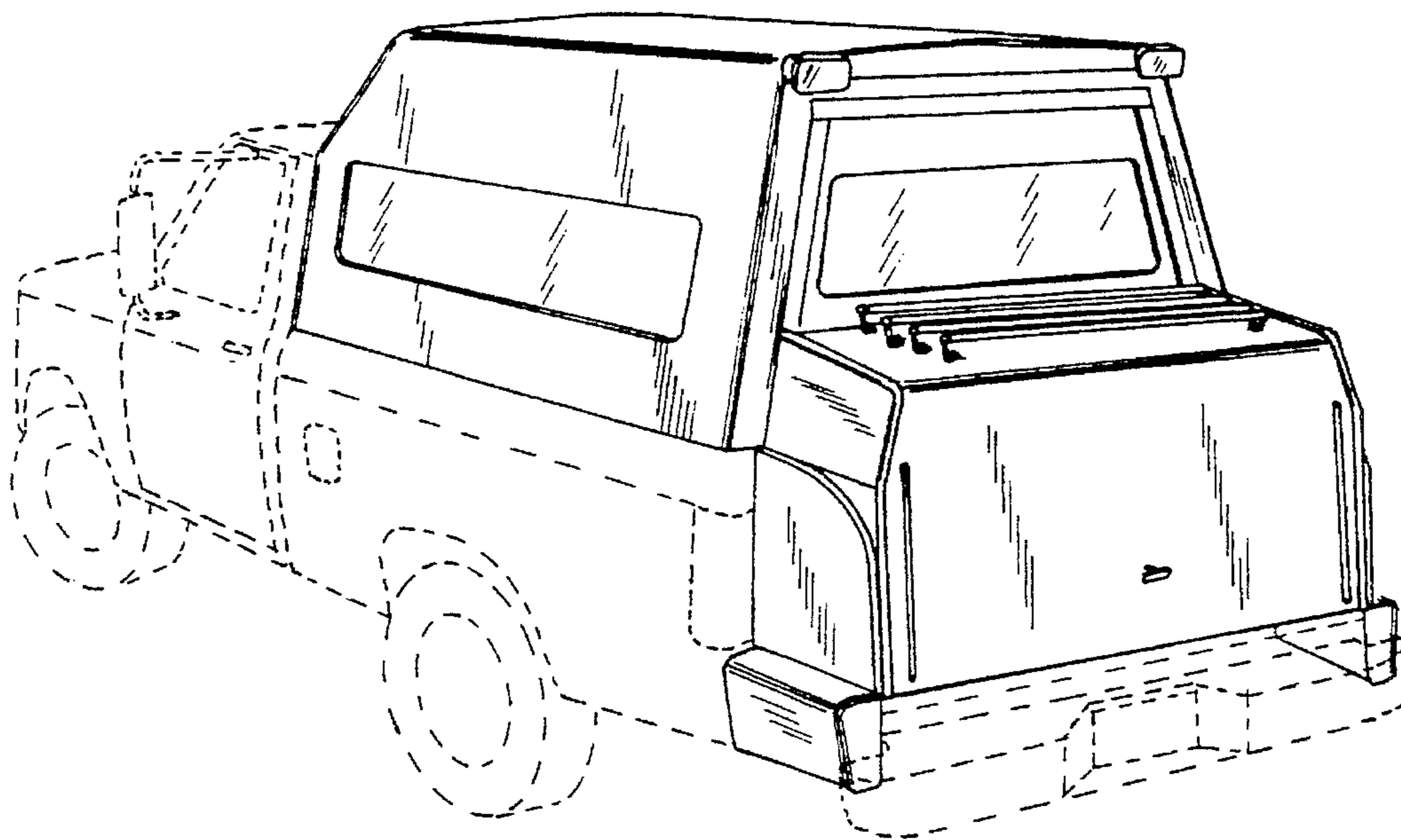

Figure 1

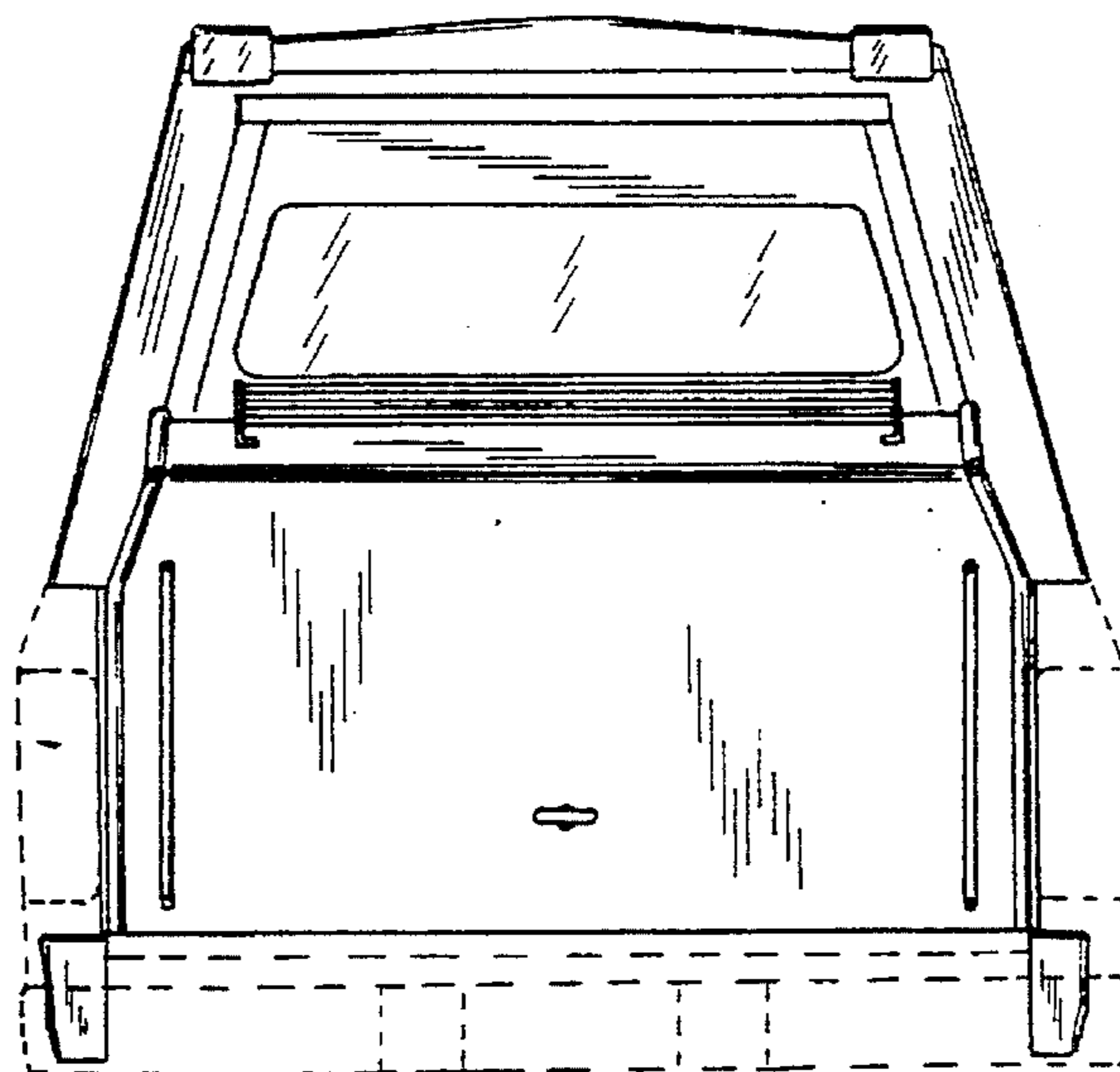

Figure 2

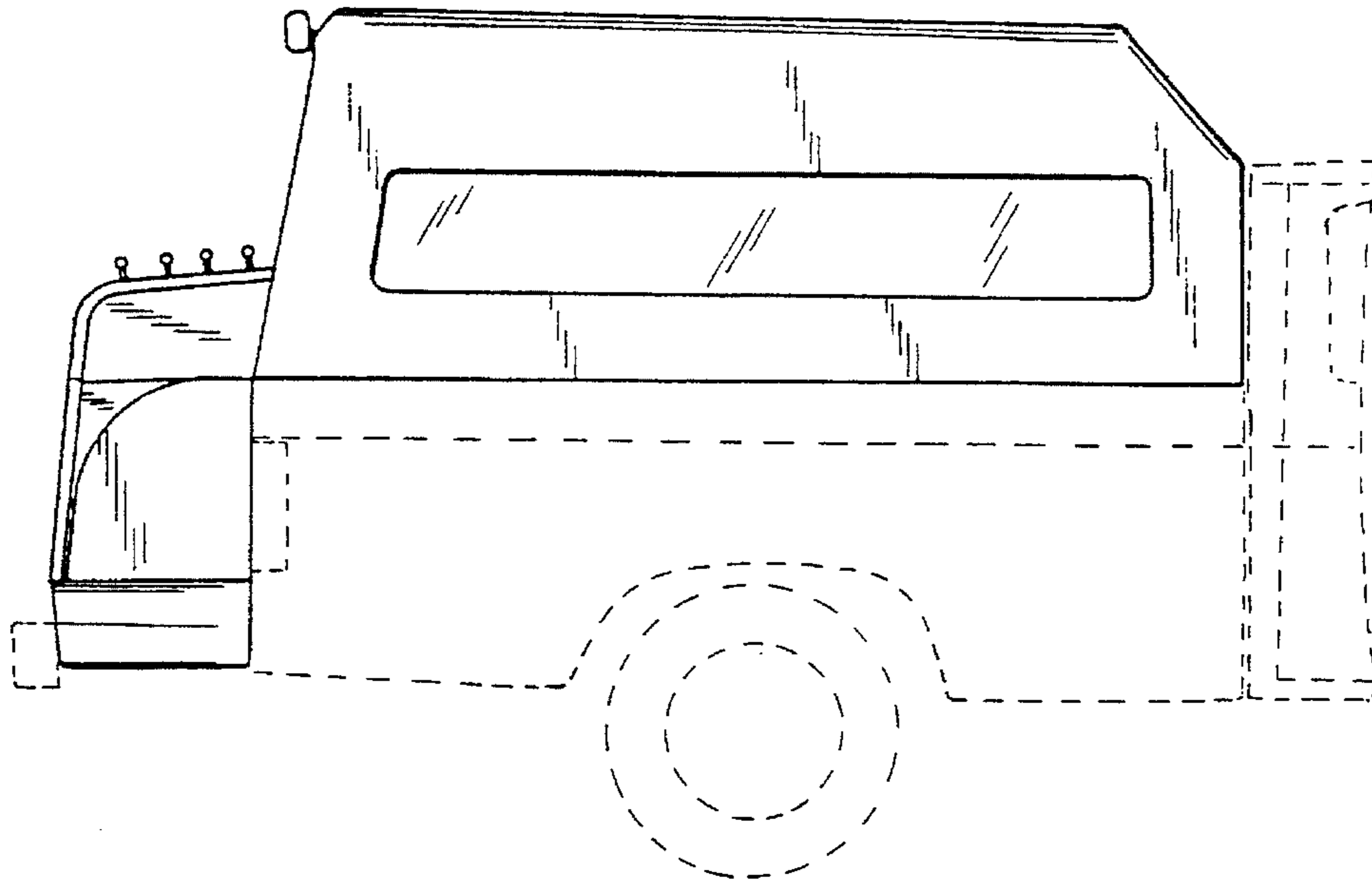

Figure 3

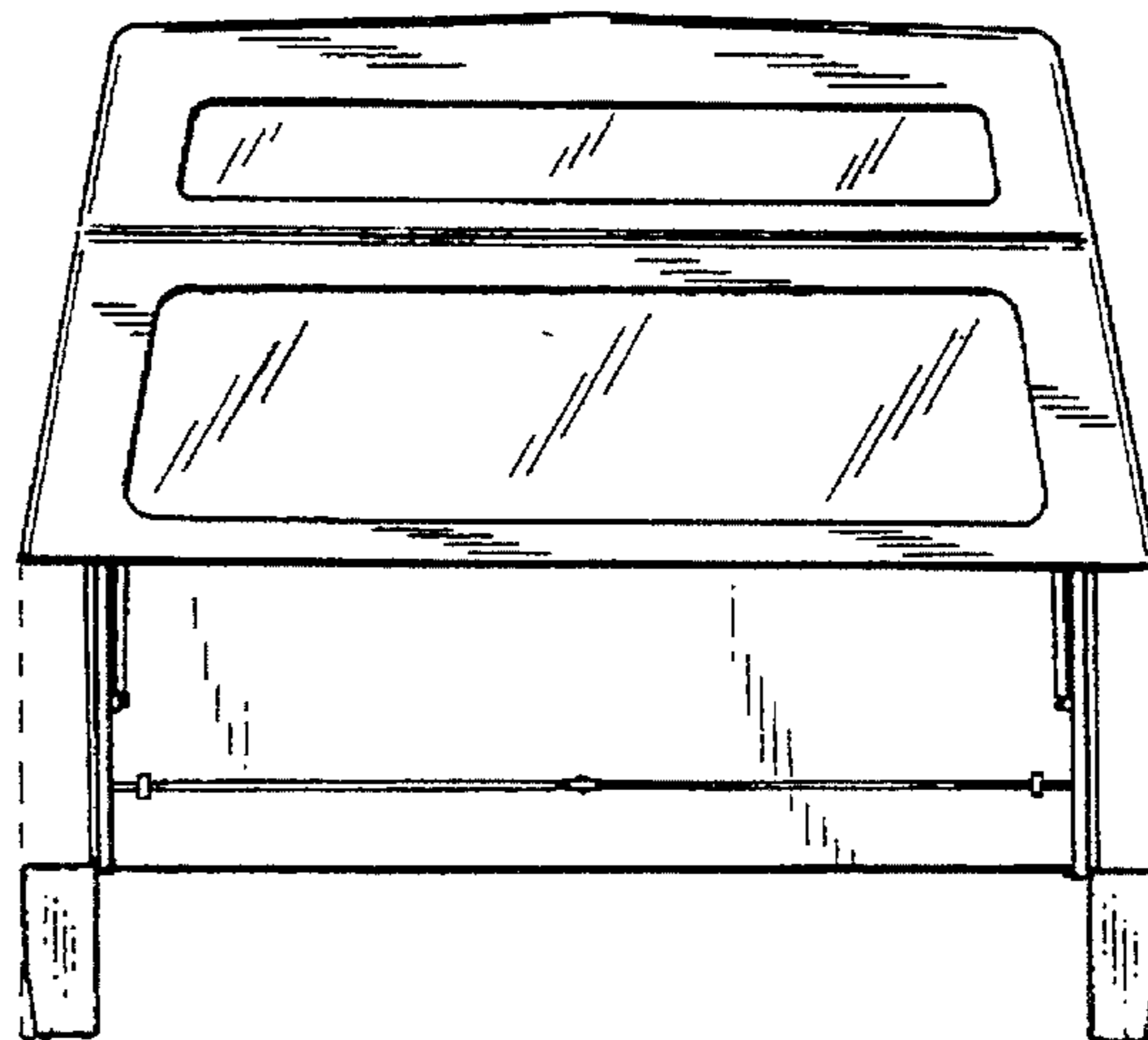

Figure 4

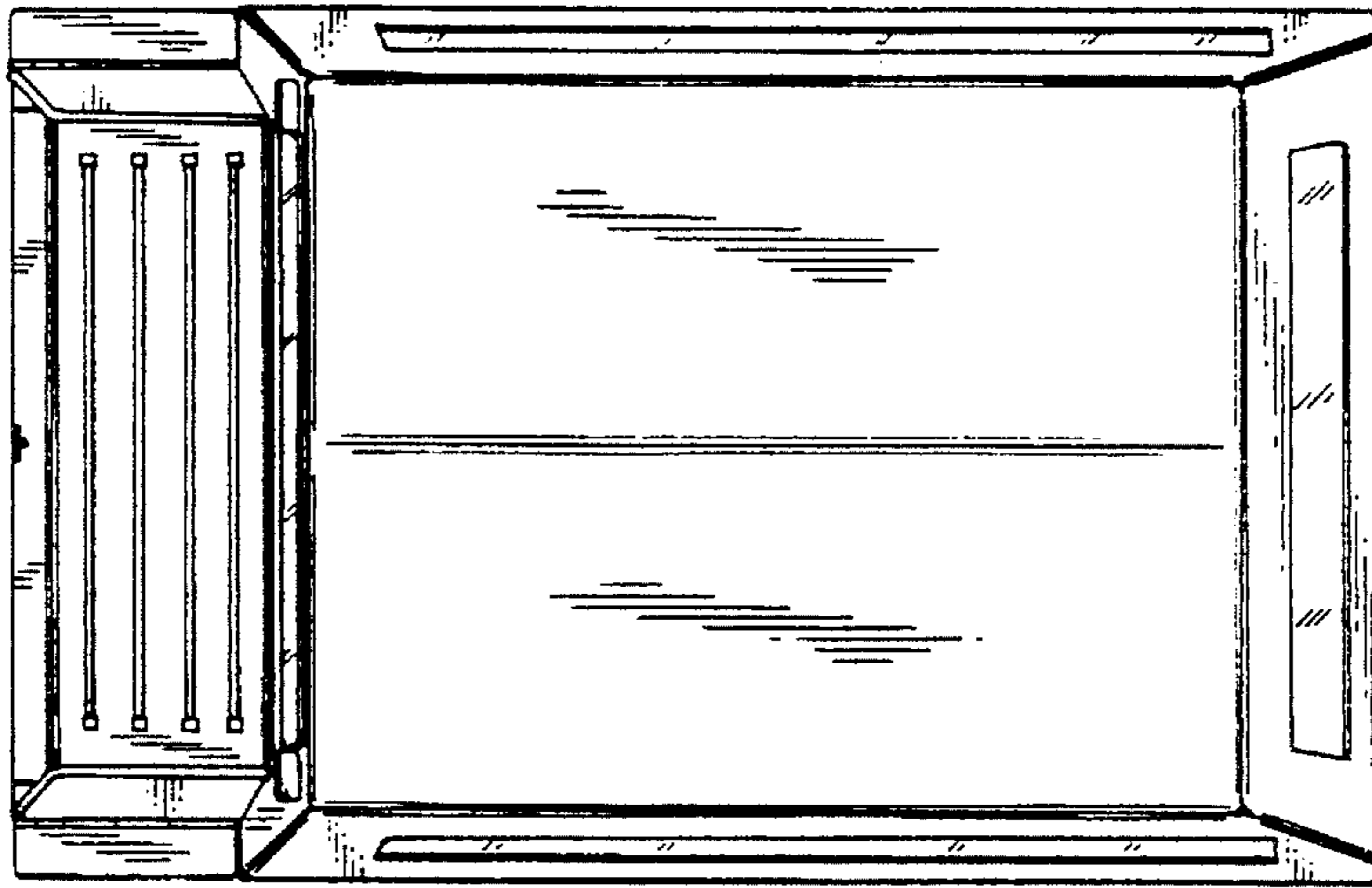

Figure 5

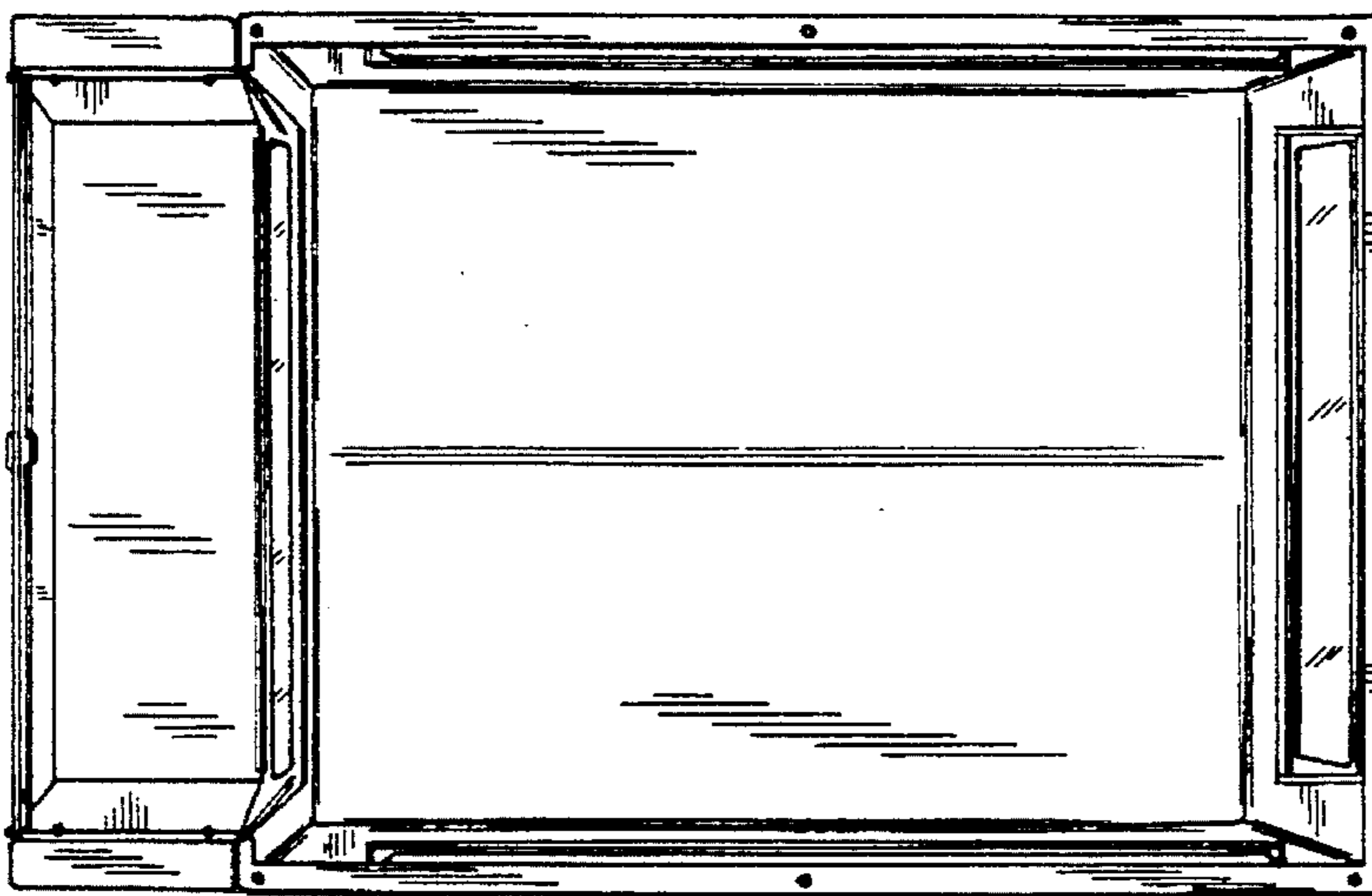

Figure 6

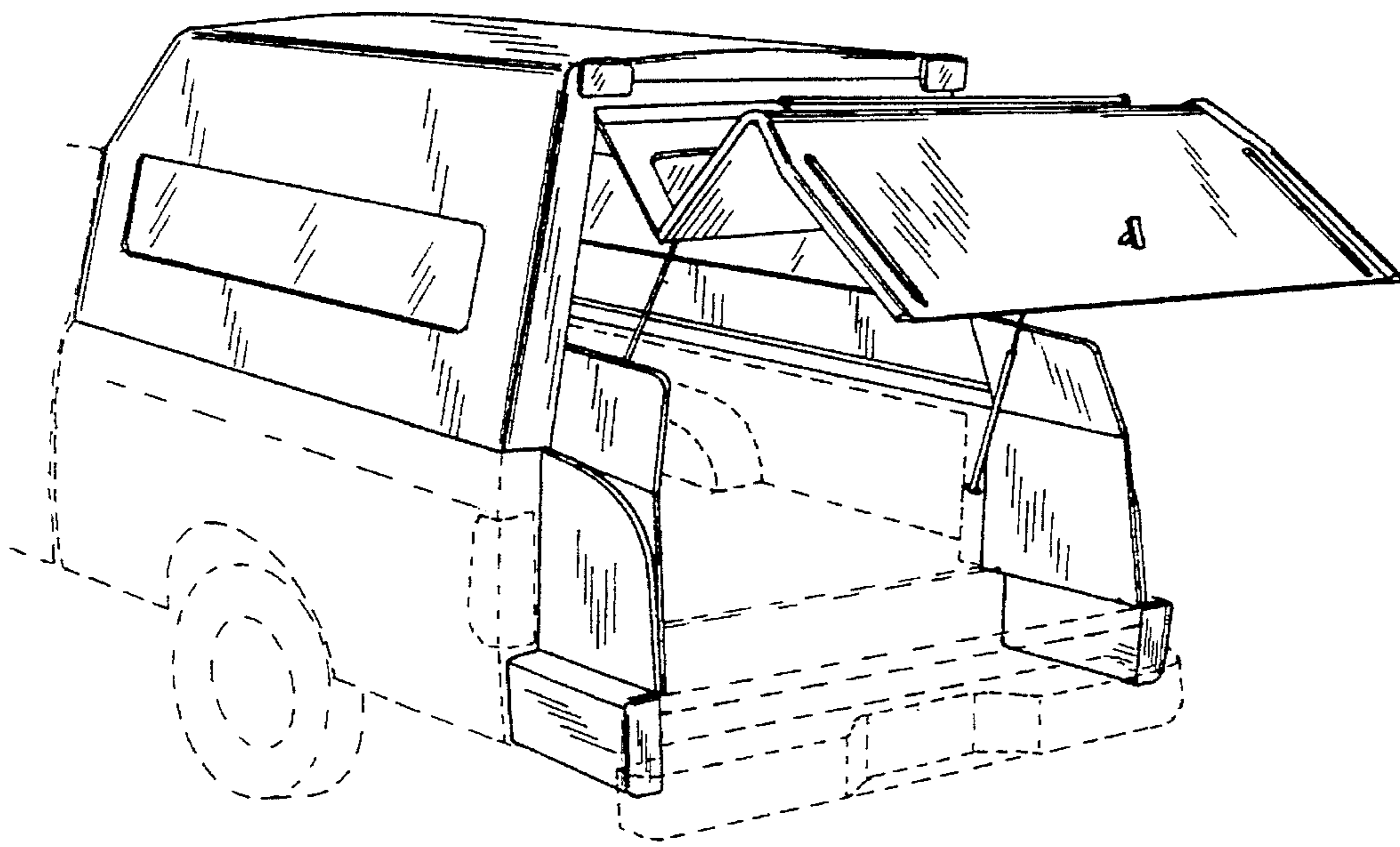

Figure 7