



US00D367441S

# United States Patent [19]

[11] Patent Number: **Des. 367,441**

Taylor et al.

[45] Date of Patent: **\*\*Feb. 27, 1996**

[54] PASSENGER VEHICLE BODY

Primary Examiner—James M. Gandy

Attorney, Agent, or Firm—Thomas A. Gallagher

[75] Inventors: **Charles F. Taylor**, Newport Beach;  
**Christopher V. Chapman**, Garden Grove, both of Calif.

[57] CLAIM

The ornamental design for a passenger vehicle body, as shown and described.

[73] Assignee: **Isuzu Motors Limited**, Tokyo, Japan

[\*\*] Term: **14 Years**

### DESCRIPTION

[21] Appl. No.: **14,120**

FIG. 1 is a front, right side perspective view of a passenger vehicle body showing our new design;

FIG. 2 is a rear, right side perspective view thereof;

[22] Filed: **Oct. 13, 1993**

FIG. 3 is a top plan view thereof;

[52] U.S. Cl. .... **D12/91**

FIG. 4 is a left side elevation view thereof;

[58] Field of Search ..... D12/91, 92; 296/185

FIG. 5 is a front elevation view thereof; and,

FIG. 6 is a rear elevation view thereof.

[56] **References Cited**

The broken line showing of environmental structure in the drawing is for illustrative purposes only and forms no part of the claimed design.

### U.S. PATENT DOCUMENTS

D. 318,827 8/1991 Wada et al. .... D12/91

D. 318,828 8/1991 Wada et al. .... D12/91

**1 Claim, 5 Drawing Sheets**

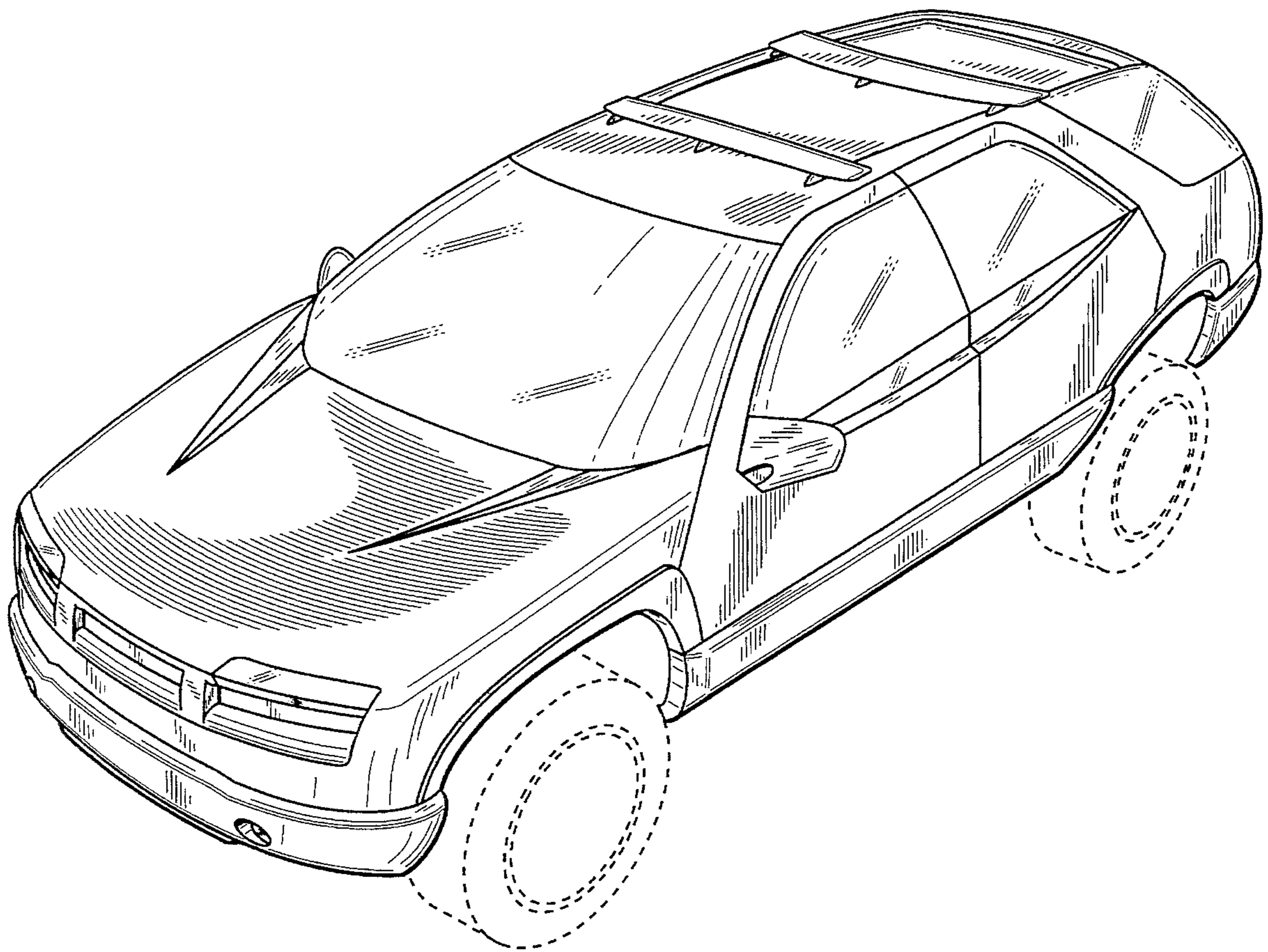

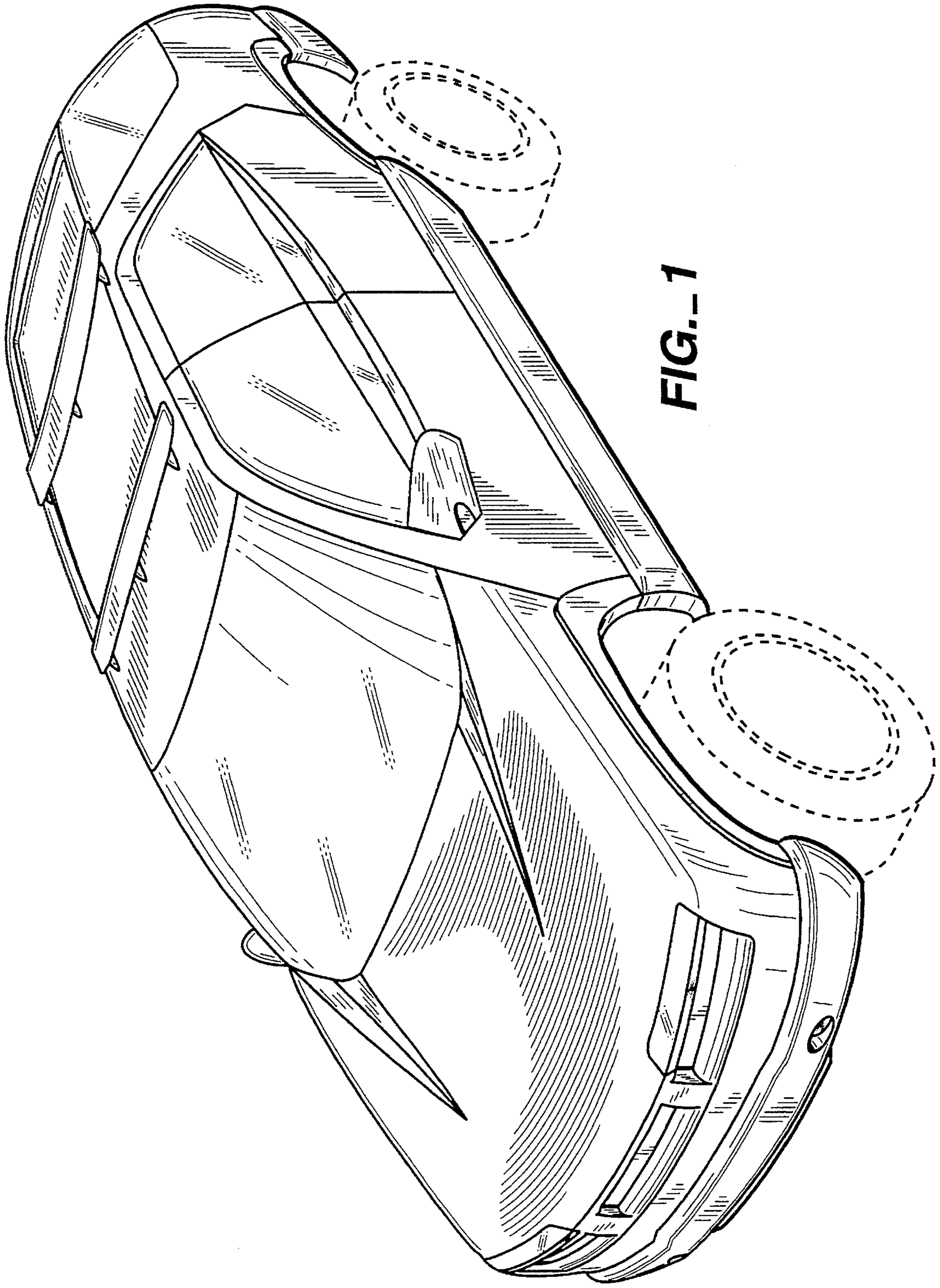

FIG.-1



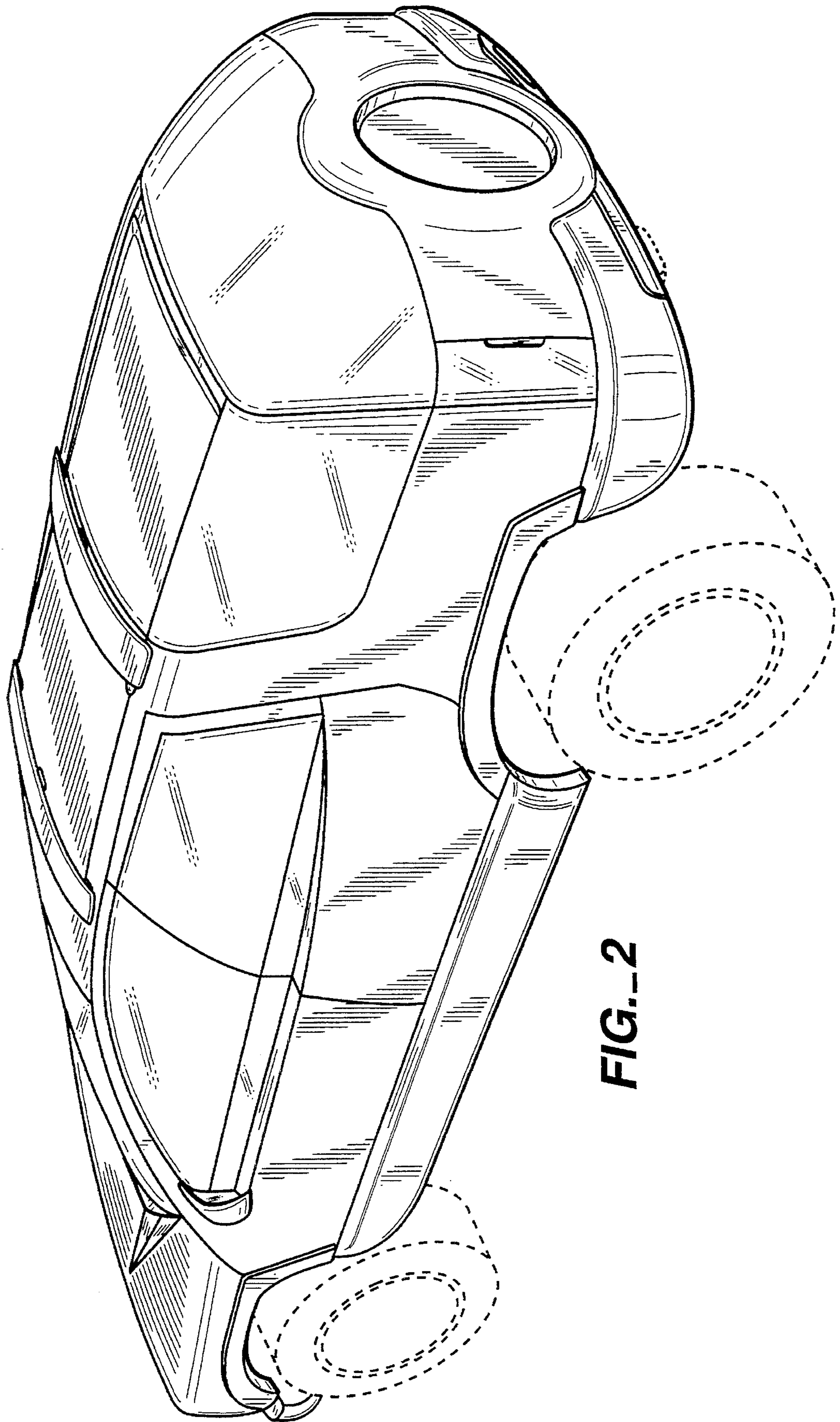
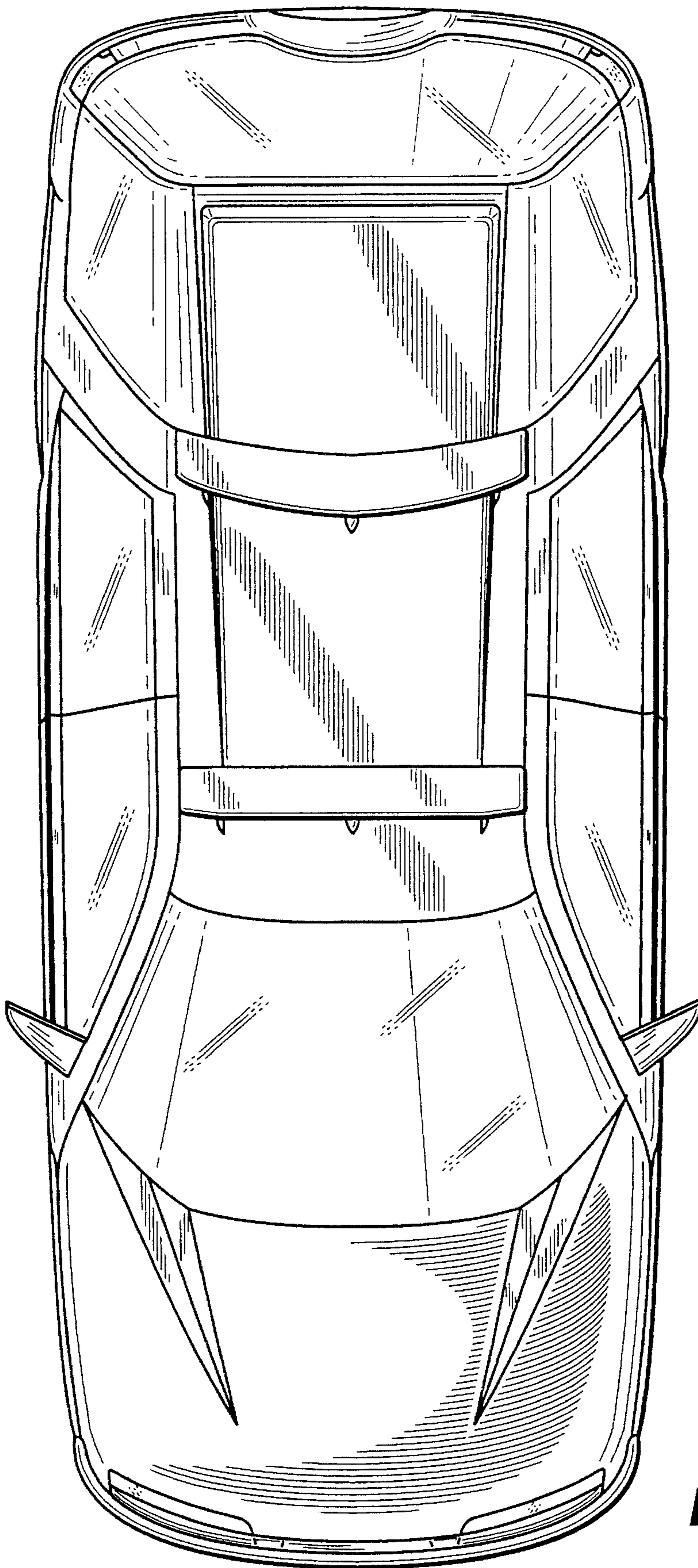
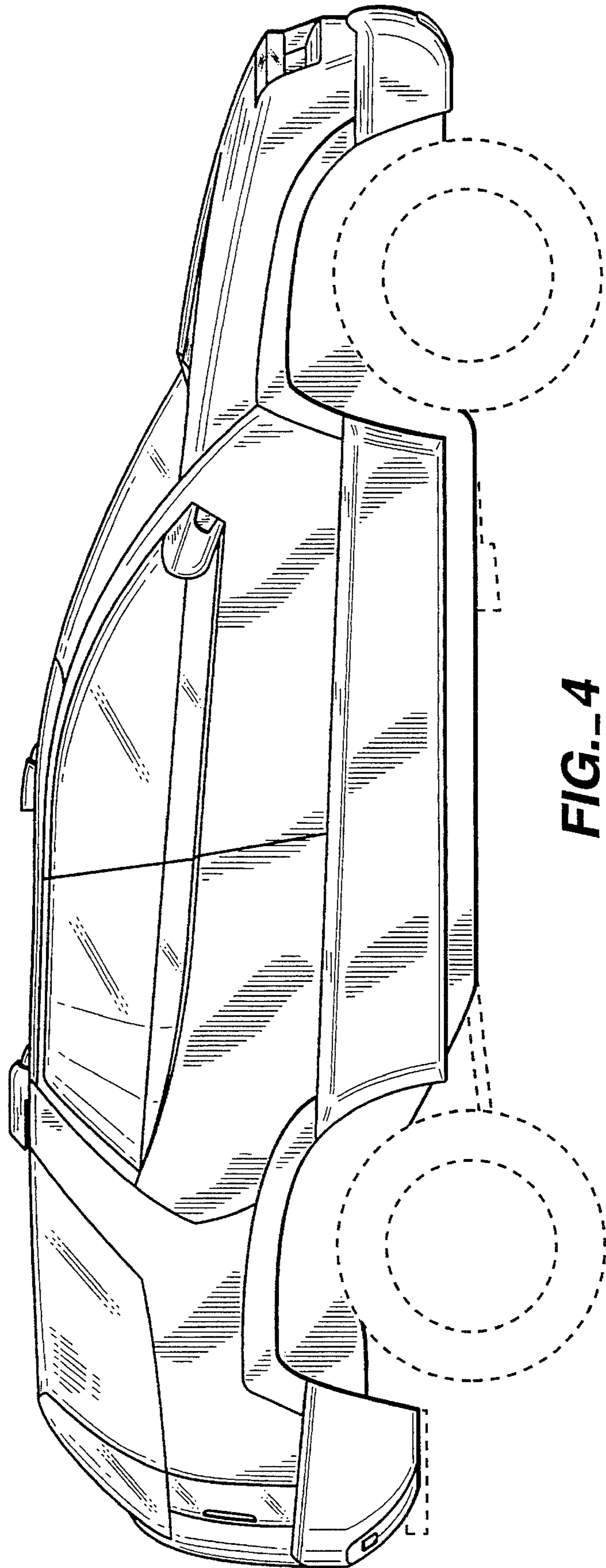

FIG.-2

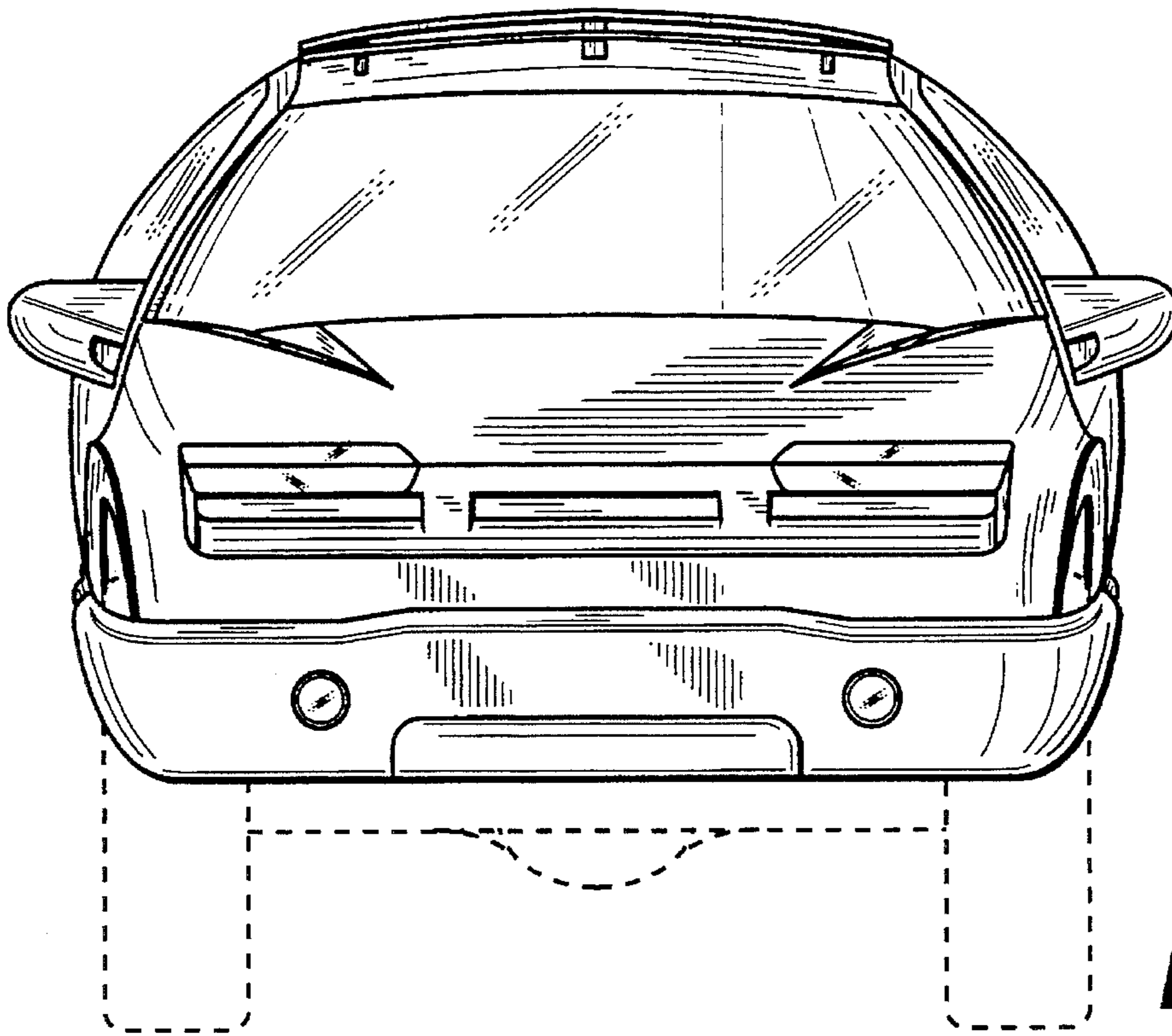

**FIG. 3**

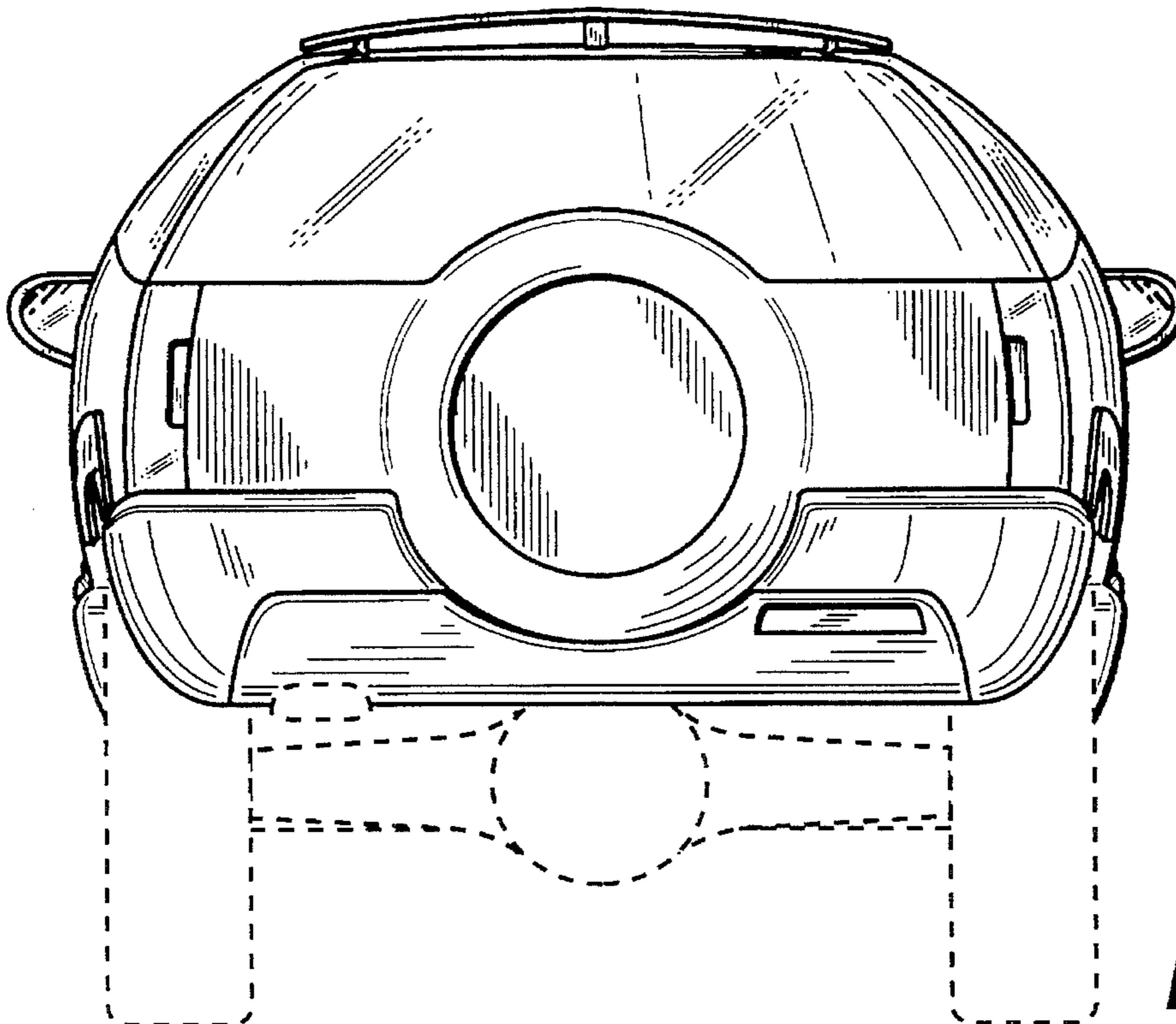

**FIG. 4**





**FIG. 5**



**FIG. 6**