



US00D367440S

United States Patent [19]

Mays

[11] Patent Number: **Des. 367,440**

[45] Date of Patent: ****Feb. 27, 1996**

[54] **AUTOMOBILE**

[75] Inventor: **Jay C. Mays**, Woodland Hills, Calif.

[73] Assignee: **Volkswagen AG**, Wolfsburg, Germany

[**] Term: **14 Years**

[21] Appl. No.: **23,405**

[22] Filed: **May 24, 1994**

[52] U.S. Cl. **D12/90**

[58] Field of Search **D12/82-100; 296/185**

[56] References Cited

U.S. PATENT DOCUMENTS

D. 172,249	5/1954	Rivolta	D12/90
D. 273,098	3/1984	Ohhashi	D12/90
D. 336,868	6/1993	Dehner et al.	D12/92
D. 352,482	11/1994	Cannara et al.	D12/90

OTHER PUBLICATIONS

Modern Plastics Meinkel Car, top of page, Mar. 1960.
Design News Ford Concept Car Shusher, Sep. 7, 1981.

Primary Examiner—M. H. Tung
Attorney, Agent, or Firm—Watson, Cole, Grindle & Watson

[57] CLAIM

The ornamental design for an automobile, as shown and described.

DESCRIPTION

FIG. 1 is a front, left perspective view of an automobile according to the present invention;

FIG. 2 is a rear, left perspective view;

FIG. 3 is a front elevational view;

FIG. 4 is a top plan view thereof, on a reduced scale;

FIG. 5 is a rear elevational view;

FIG. 6 is a left side elevational view, on a reduced scale, the right side is a mirror image.

The broken line drawings of wheels in FIGS. 1-3 and 5-6 are for illustrative purposes only and form no part of the claim design.

1 Claim, 6 Drawing Sheets

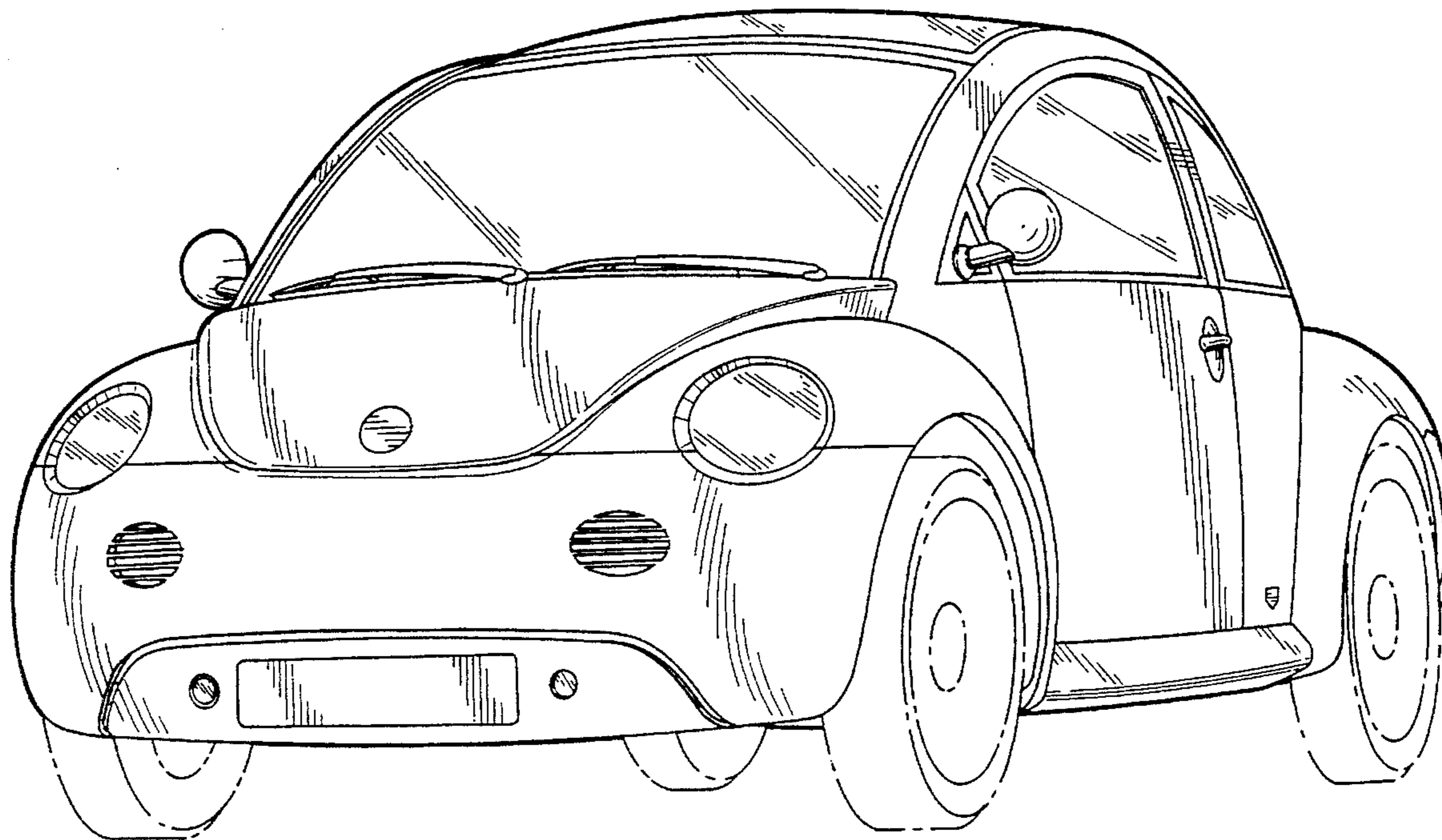

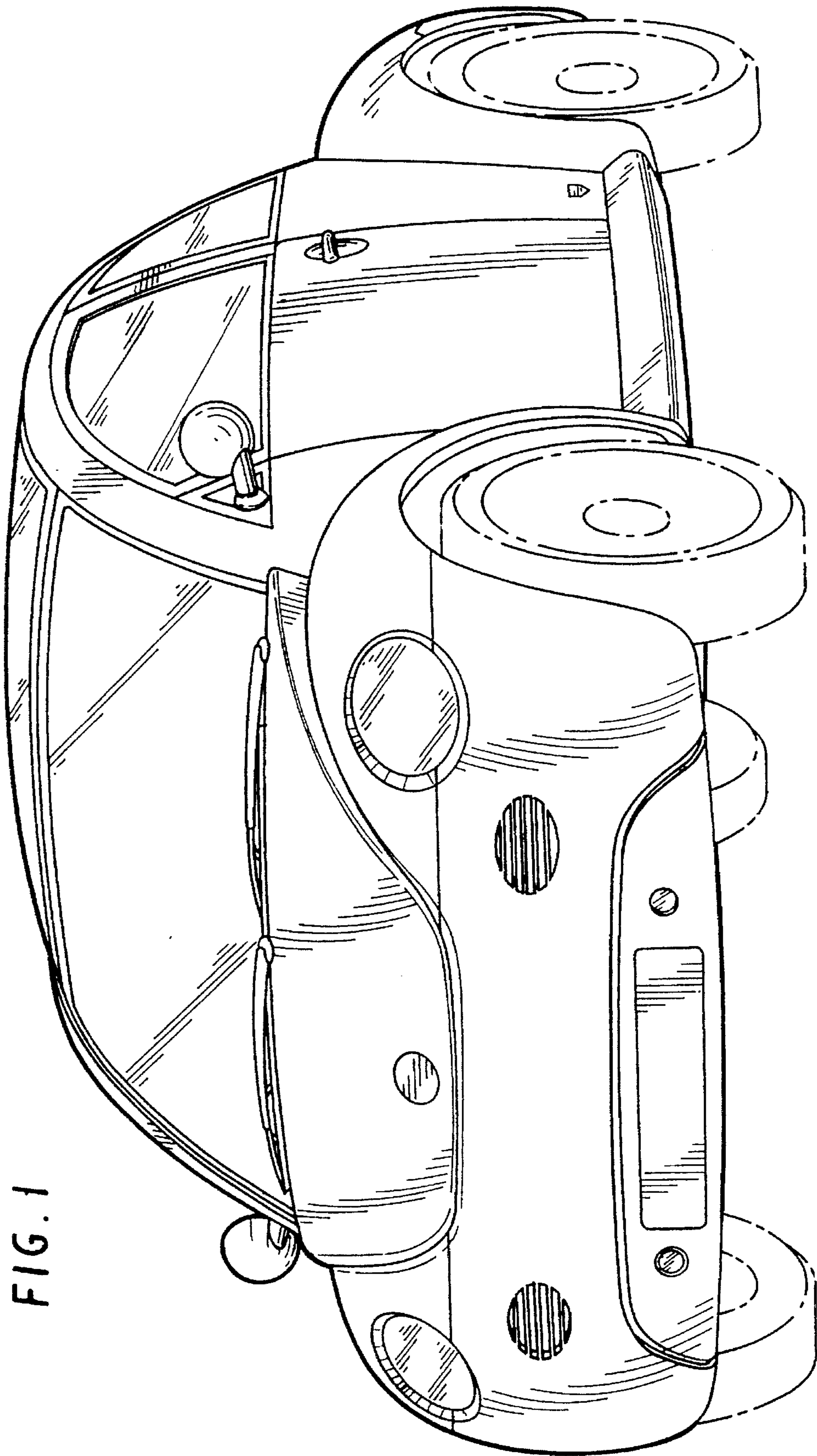

FIG. 1

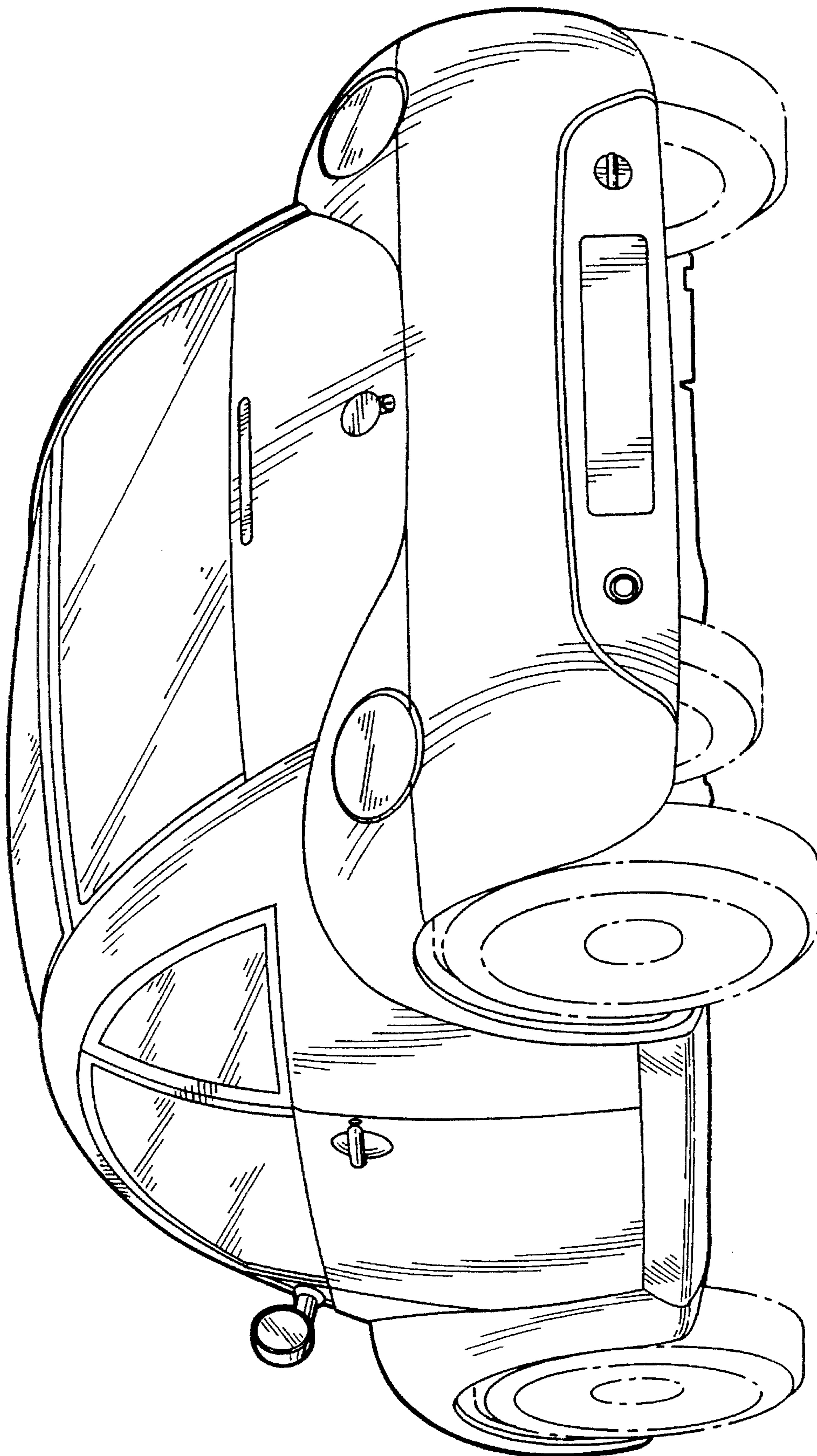

FIG. 2

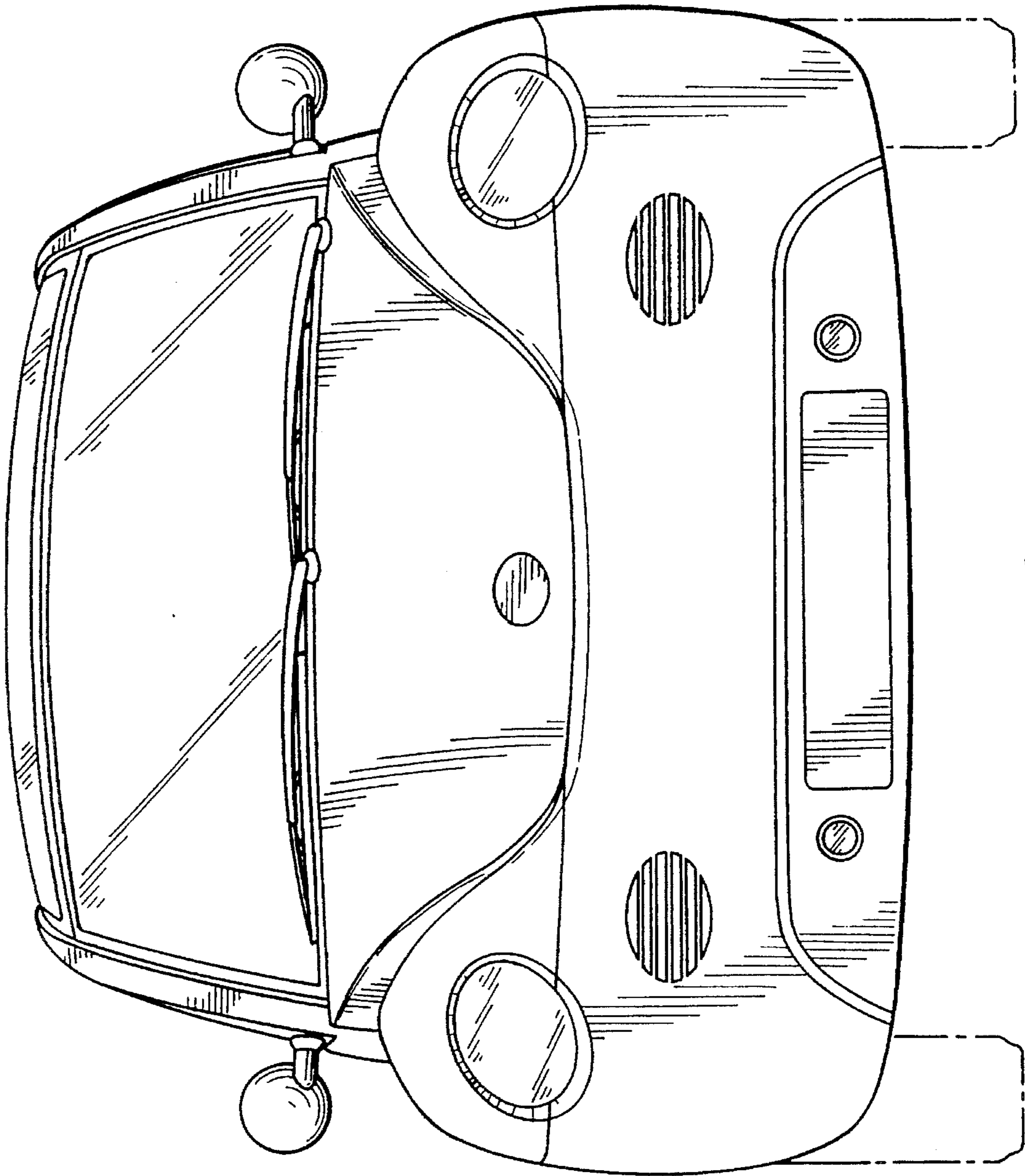

FIG. 3

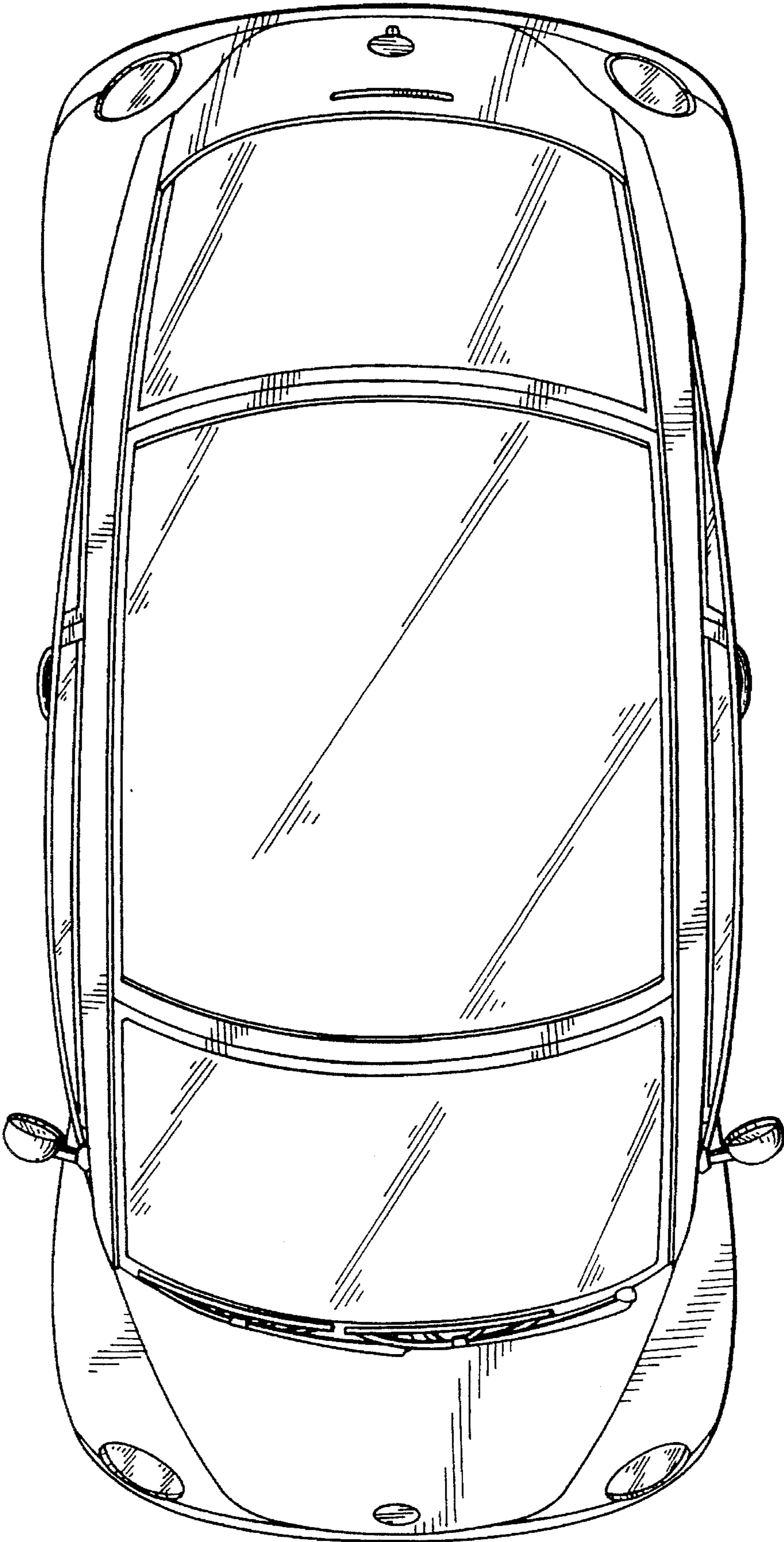

FIG. 4

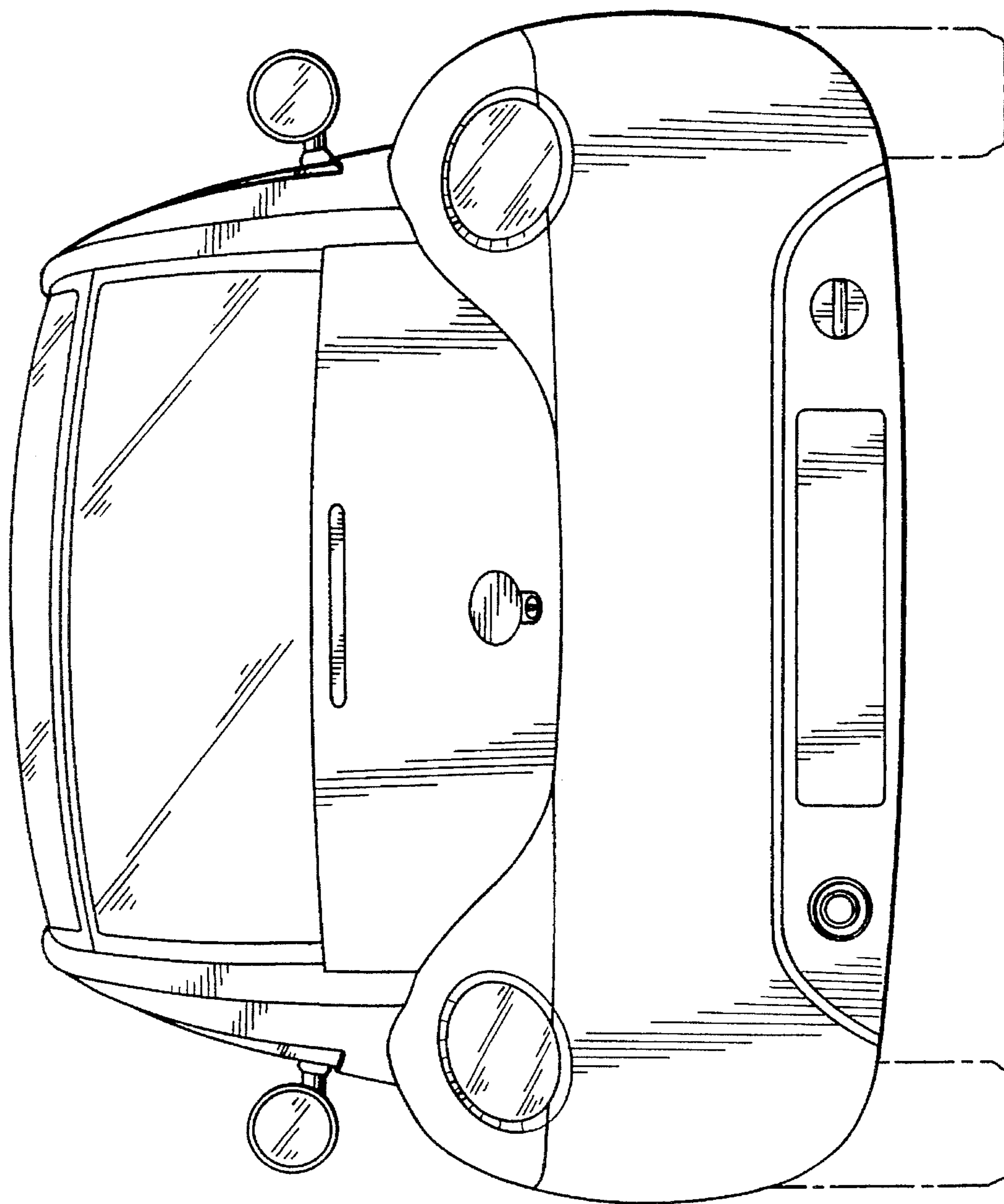

FIG. 5

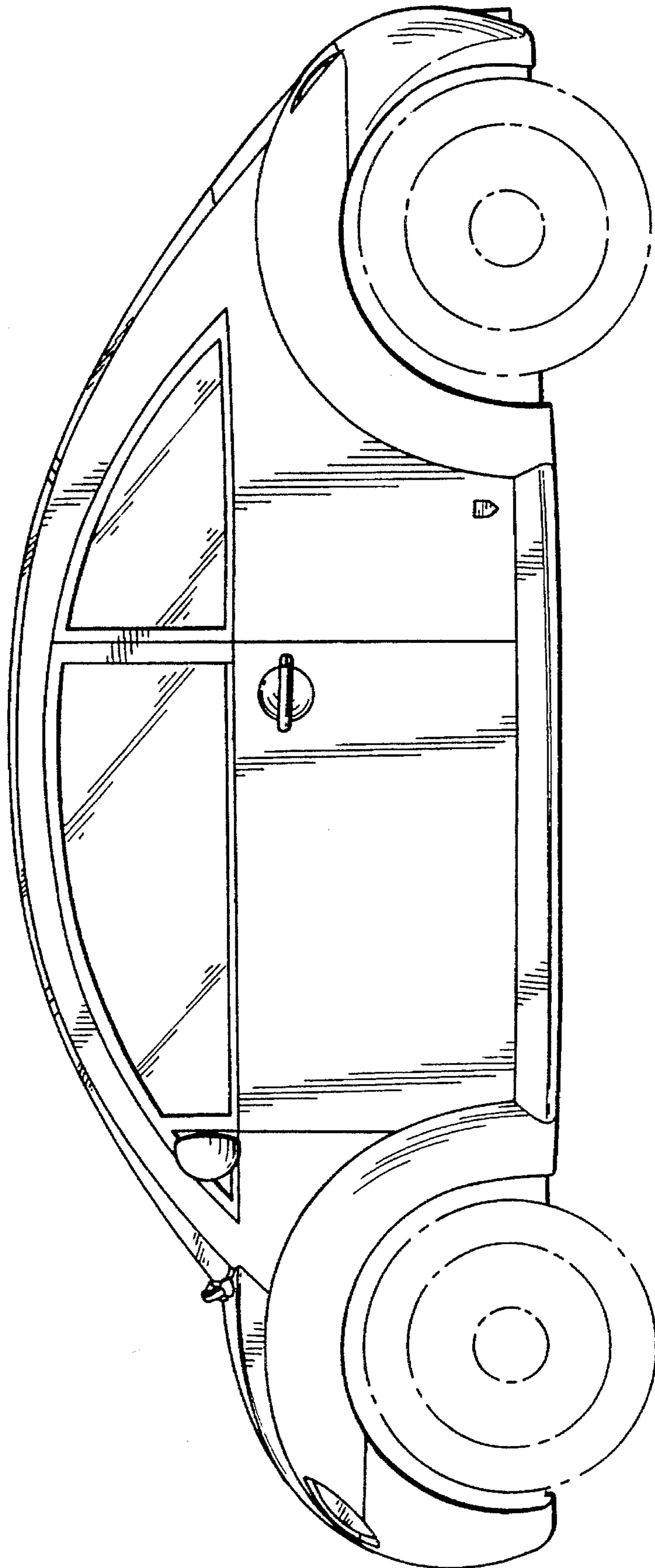

FIG. 6