



US00D367316S

# United States Patent [19]

[11] Patent Number: **Des. 367,316**

Sondén et al.

[45] Date of Patent: **\*\*\* Feb. 20, 1996**

## [54] CIRCULAR SLEEVE COUPLING

[75] Inventors: **Carl-Gustaf Sondén**, Ängelholm;  
**Kenneth Lennartsson**, Torekov, both  
of Switzerland

[73] Assignee: **Lindab AB**, Bastad, Sweden

[\*] Notice: The portion of the term of this patent  
subsequent to Jul. 4, 2009, has been dis-  
claimed.

[\*\*] Term: **14 Years**

[21] Appl. No.: **6,951**

[22] Filed: **Apr. 9, 1993**

### [30] Foreign Application Priority Data

Mar. 1, 1993	[DE]	Germany	.....	0224 93
[52]	U.S. Cl.	.....	<b>D23/262</b>	
[58]	Field of Search	.....	D23/262, 263, D23/264, 265; 285/424; 138/109; 16/2, 108, 109; 277/207 A	

### [56] References Cited

#### U.S. PATENT DOCUMENTS

2,535,186	12/1950	Anderson	.....	285/424 X
3,327,945	6/1967	Pfister	.....	285/424 X
3,368,830	2/1968	French	.....	277/207 A
4,007,941	2/1977	Stancati	.....	277/207 A
4,050,703	9/1977	Tuvelsson et al.	.....	277/207

#### OTHER PUBLICATIONS

Product Catalog entitled "Ducts and Fittings," issued by Lindab AB, Caswell Road, Brackmills Industrial Estate, Northampton NN4 OBR, England, 52 pp., first distributed in 1987.

Product Catalog entitled "Circular Duct System," issued by Lindab AB, 45 Caswell Road, Brackmills Business Park, Northampton NN4 OPW, England, 42 pp., Mar. 1992.

Swedish-language Product Catalog entitled "VELODUCT Cirkulärt kanalsystem," issued by Fläkt VELODUCT AB, Prästgårdsvägen 15, Box 84, 153 00 Järna, Sweden, 29 pp., Jun. 1991.

Product literature entitled "SPIRO Bend Segment Cutting Machine 1" issued by Spiro Investment AG, Industriestrasse, CH-3178 Boesingen, Switzerland, 2 pp., first distributed c. 1978.

Product literature entitled "SPIRO Bend Segment Cutting Machine II" issued by SPIRO Investment AG, Industriestrasse, CH-3178 Boesingen, Switzerland, 6 pp., first distributed c. 1980.

German-language Product literature entitled "Kurven-schneidemaschine delta 2," issued by SUTER AG SEON, 5703 Seon/Schweiz, Switzerland, 6 pp., first distributed c. 1982.

Product literature entitled "Seam Forming and Locking Machine beta 2," issued by SUTER AG SEON, 5703 Seon Schweiz, Switzerland, 4 pp., first distributed c. 1982.

Curve Cutting Machine Delta 2 issued by Emil Suter Maschinenfabrik AG, CH-5703 Seon/Schweiz (English translation).

*Primary Examiner*—Louis S. Zarfes

*Assistant Examiner*—Eric Watterson

*Attorney, Agent, or Firm*—Weingarten, Schurgin, Gagnebin & Hayes

### [57] CLAIM

The ornamental design for a circular sleeve coupling, as shown and described.

### DESCRIPTION

FIG. 1 is a perspective view of a circular sleeve coupling, showing our new design, as seen obliquely from the front; FIG. 2 is a perspective view of the sleeve coupling, as seen obliquely from the back; and, FIG. 3 is a side elevation of the sleeve coupling, the opposite side being a mirror image thereto.

**1 Claim, 1 Drawing Sheet**

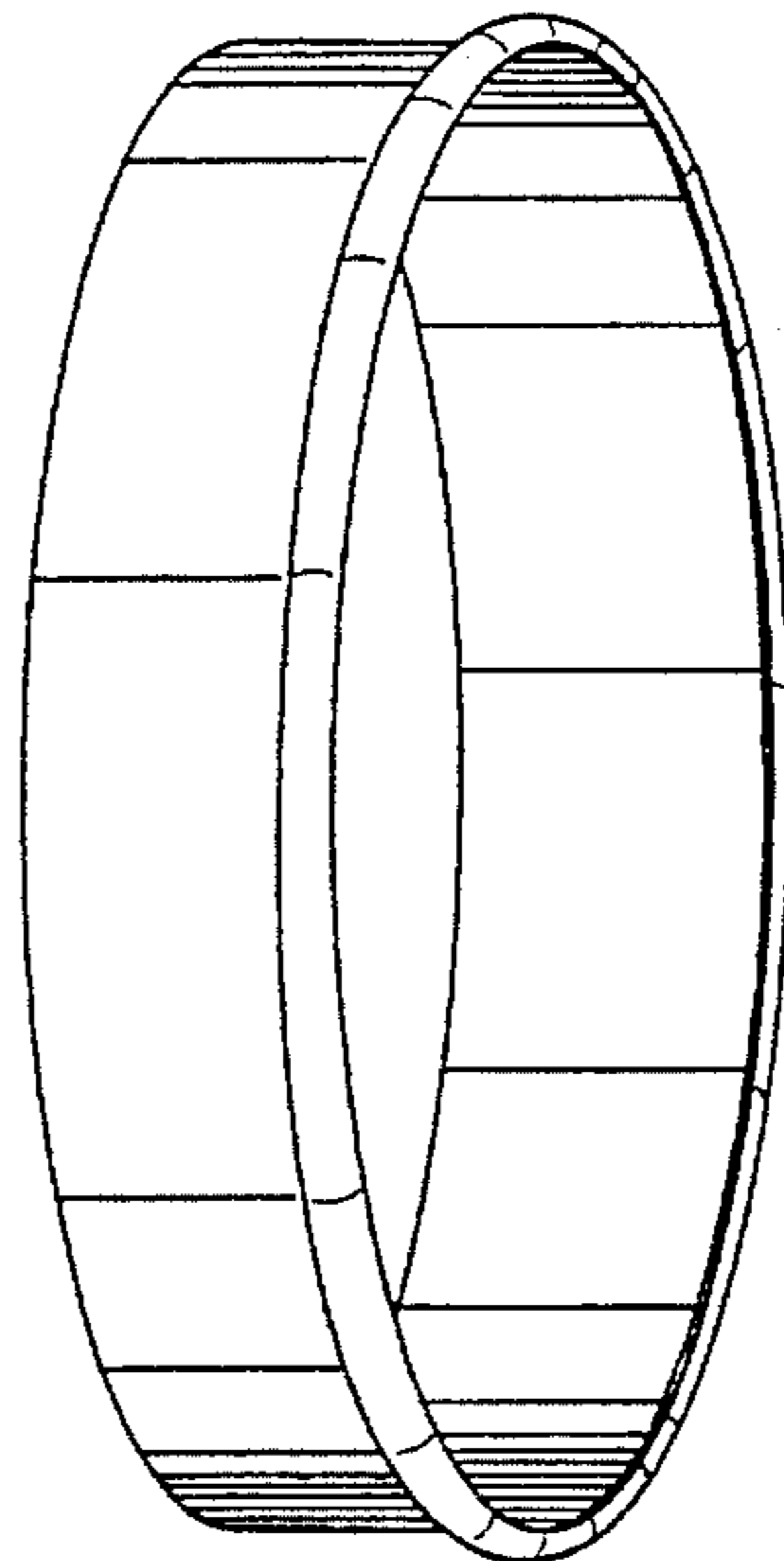

FIG.1

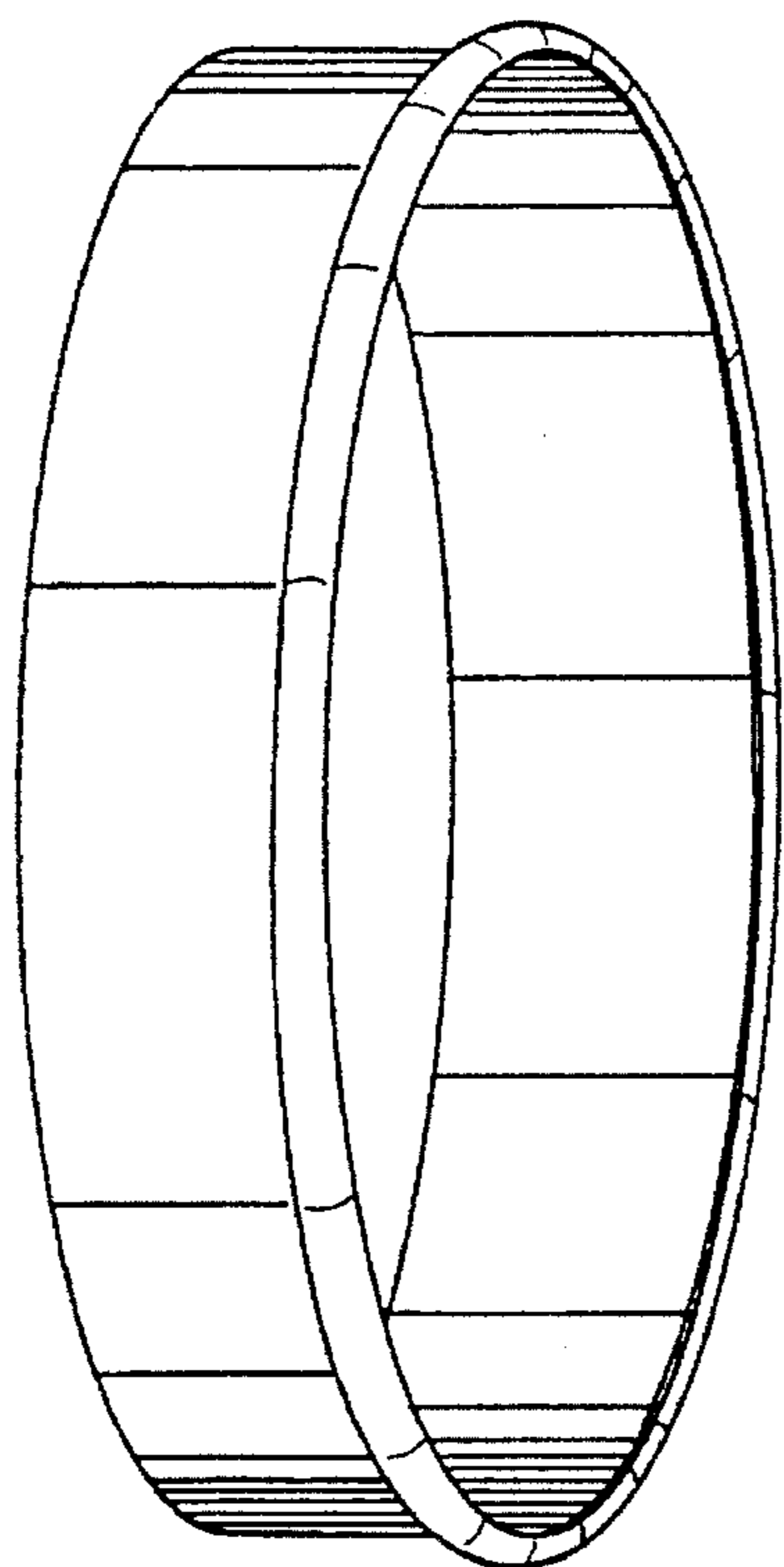

FIG.2

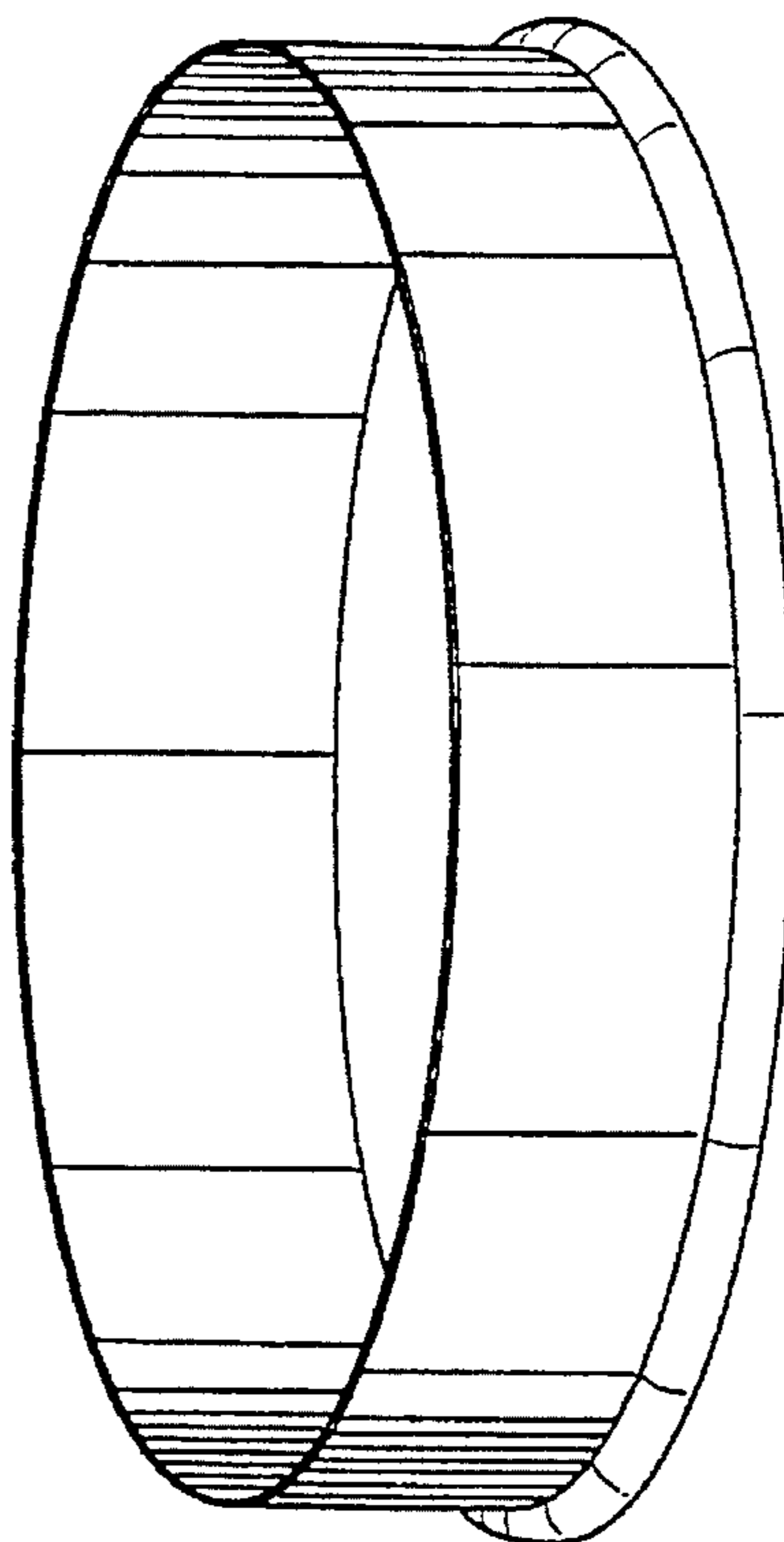
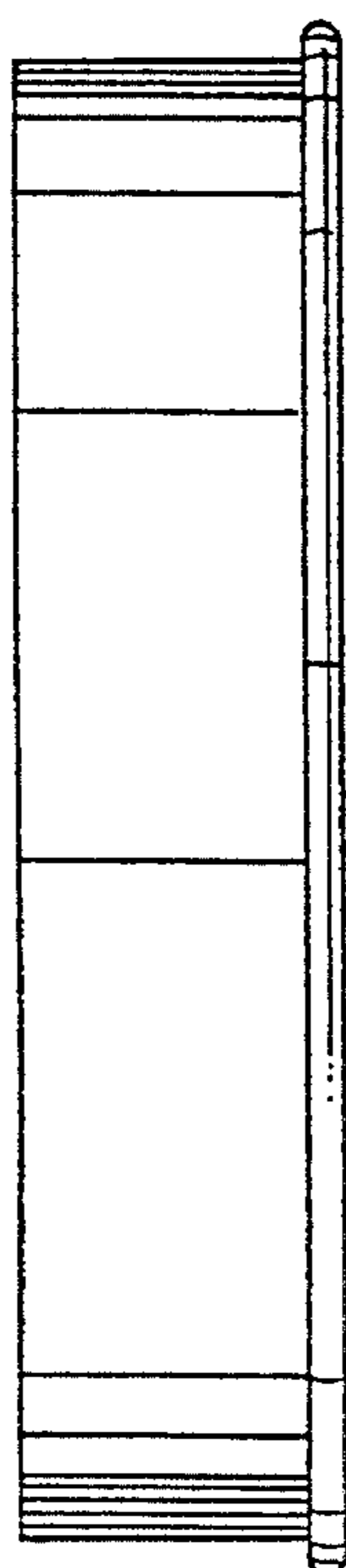

FIG.3



UNITED STATES PATENT AND TRADEMARK OFFICE  
**CERTIFICATE OF CORRECTION**

PATENT NO. : Des. 367,316  
DATED : February 20, 1996  
INVENTOR(S) : Carl-Gustaf Sonden, et al.

It is certified that error appears in the above-identified patent and that said Letters Patent is hereby corrected as shown below:

On the title page, item [75]: In the inventor's addresses, "both of Switzerland" should read --both of Sweden--.

On the title page, item [30]: In the foreign priority data, "Germany" should read --Denmark--.

Signed and Sealed this  
Sixteenth Day of July, 1996



BRUCE LEHMAN

Attest:

Attesting Officer

Commissioner of Patents and Trademarks