



US00D367253S

United States Patent [19]
Albion

[11] **Patent Number: Des. 367,253**

[45] **Date of Patent: **Feb. 20, 1996**

[54] **AIRCRAFT**

2,084,502 6/1937 Rieder 244/45 R

[75] Inventor: **Nicholas Albion**, Brookhaven, Pa.

[73] Assignee: **The Boeing Company**, Seattle, Wash.

[**] Term: **14 Years**

[21] Appl. No.: **38,343**

[22] Filed: **May 4, 1995**

OTHER PUBLICATIONS

Flight Int'l, 9 Jul. 1977, p. 130 "Tailless WPB-1" Plank.

Primary Examiner—Kay H. Chin

Attorney, Agent, or Firm—Mary Y. Redman

[57] **CLAIM**

The ornamental design for an aircraft, as shown and described.

Related U.S. Application Data

[63] Continuation of Ser. No. 19,566, Mar. 4, 1994, abandoned.

[52] **U.S. Cl.** **D12/344**; D12/326

[58] **Field of Search** D12/319, 330,
D12/331, 326, 339, 344; 244/45 A, 45 R,
199, 13, 91, 12

DESCRIPTION

FIG. 1 is a perspective view of the aircraft showing my new design, the view being taken from above and in front of the aircraft, showing the left side thereof;

FIG. 2 is a top plan view of the aircraft;

FIG. 3 is a bottom plan view of the aircraft;

FIG. 4 is a front elevation view of the aircraft;

FIG. 5 is a rear elevation view of the aircraft;

FIG. 6 is a right elevation view of the aircraft; and,

FIG. 7 is a left elevation view of the aircraft.

[56] **References Cited**

U.S. PATENT DOCUMENTS

D. 196,688 10/1963 Schnelaer D12/330

D. 311,719 10/1990 Haga D12/331

1 Claim, 5 Drawing Sheets

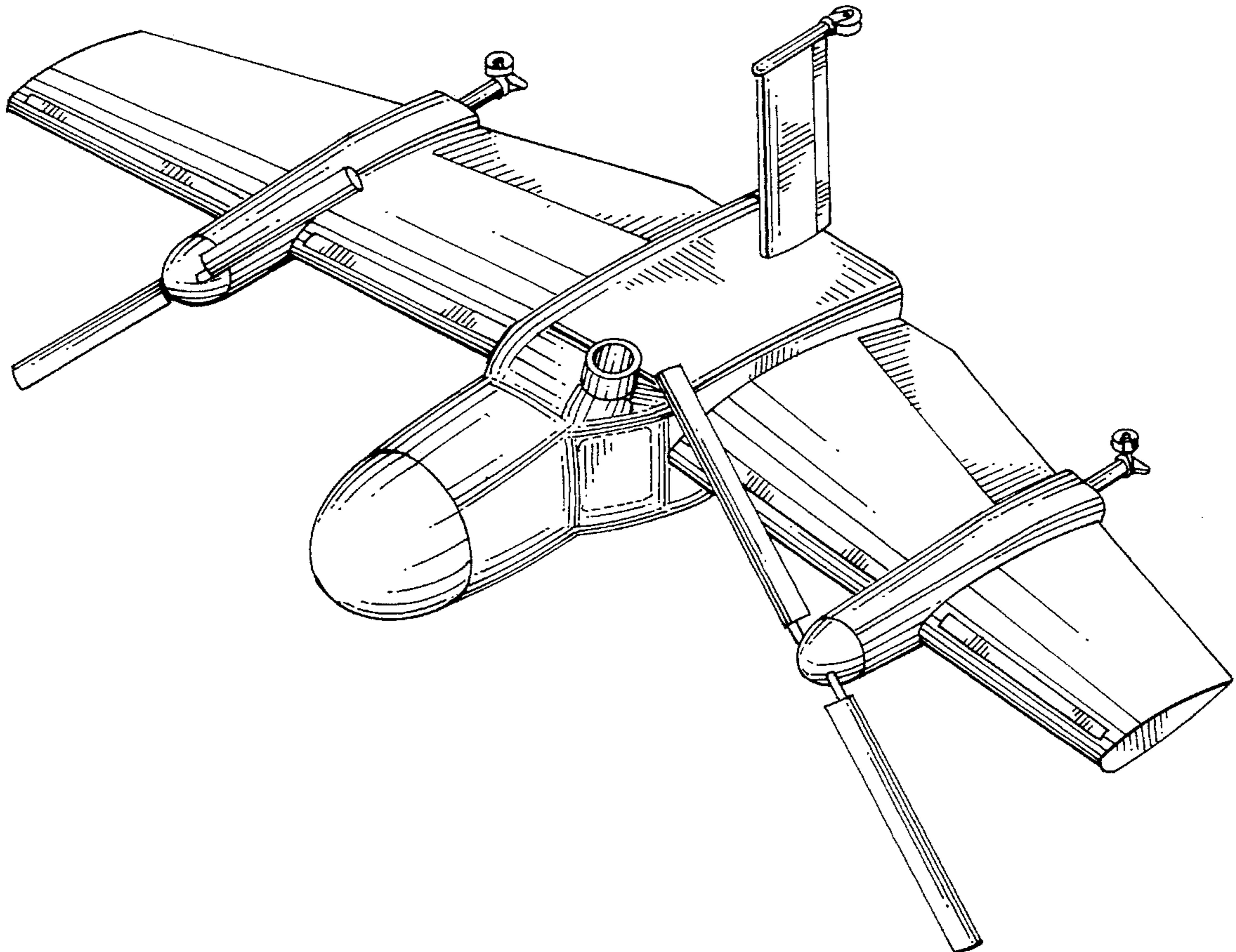

Fig. 1

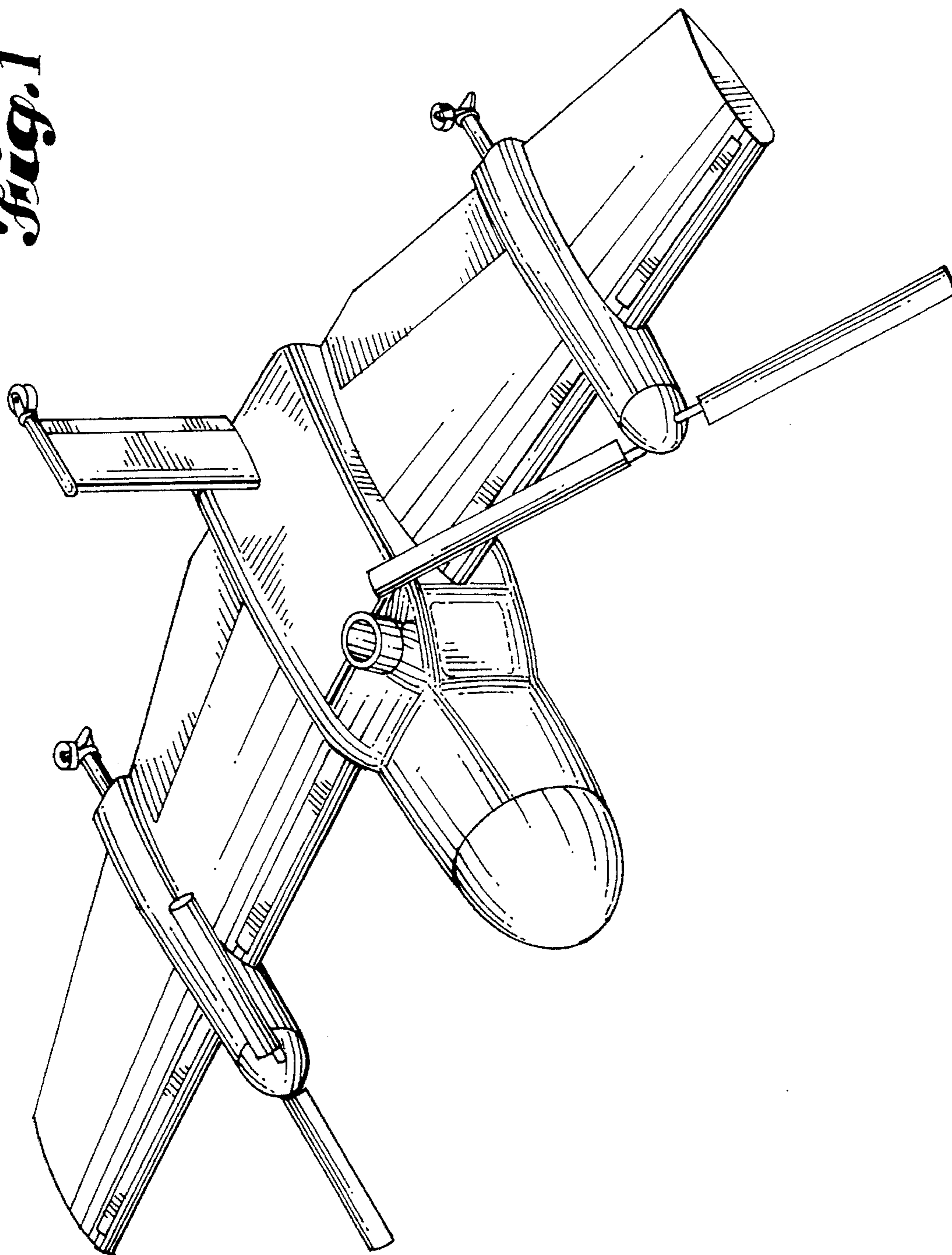

Fig. 2

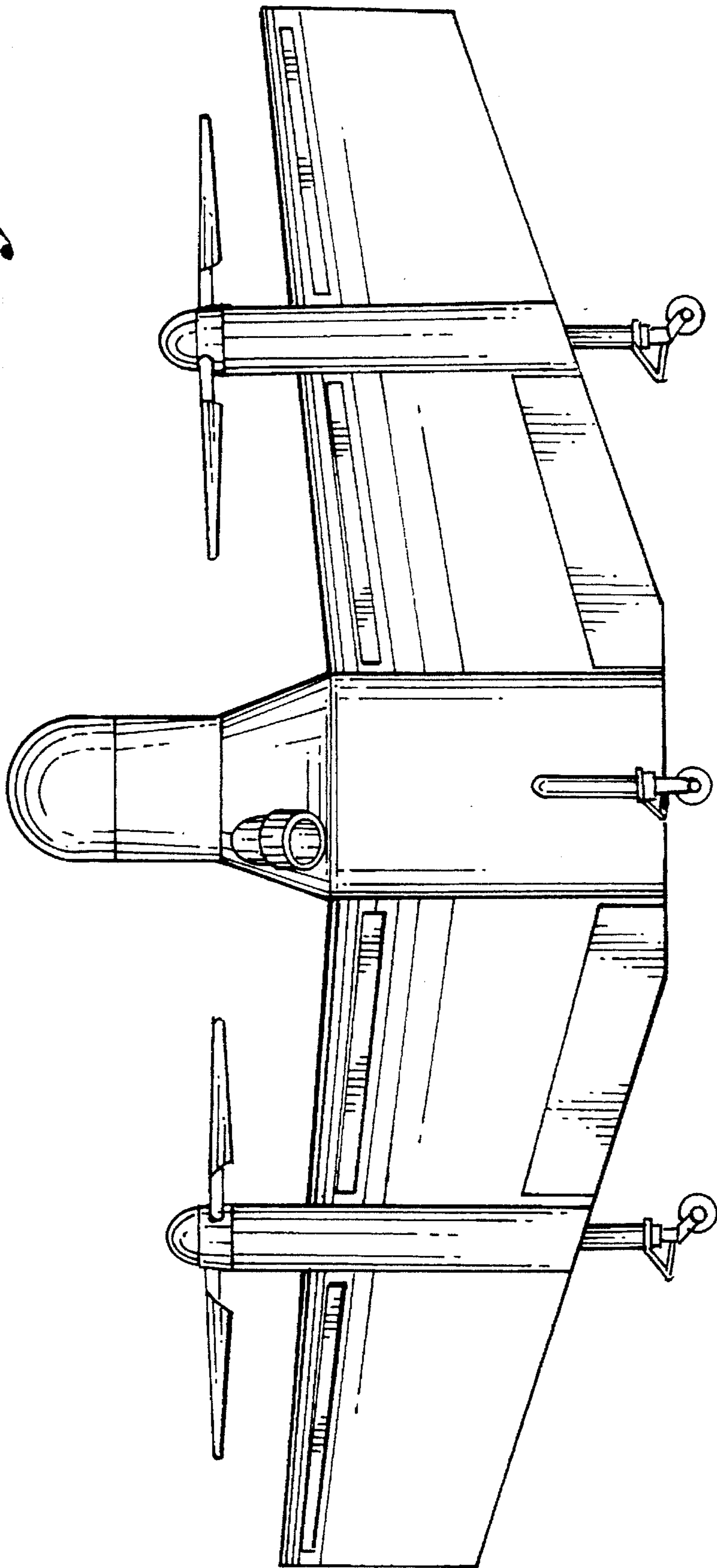

Fig. 3

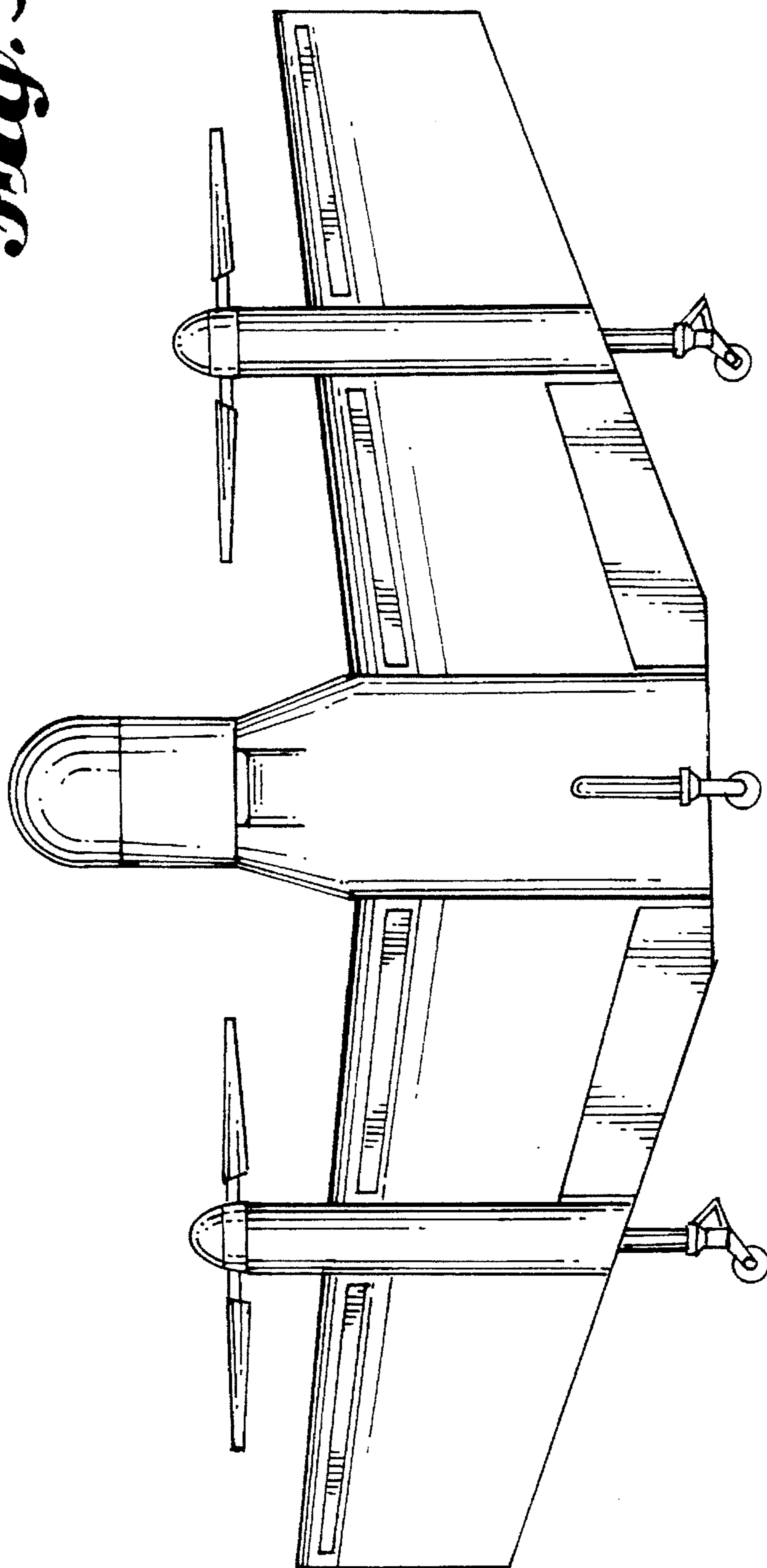
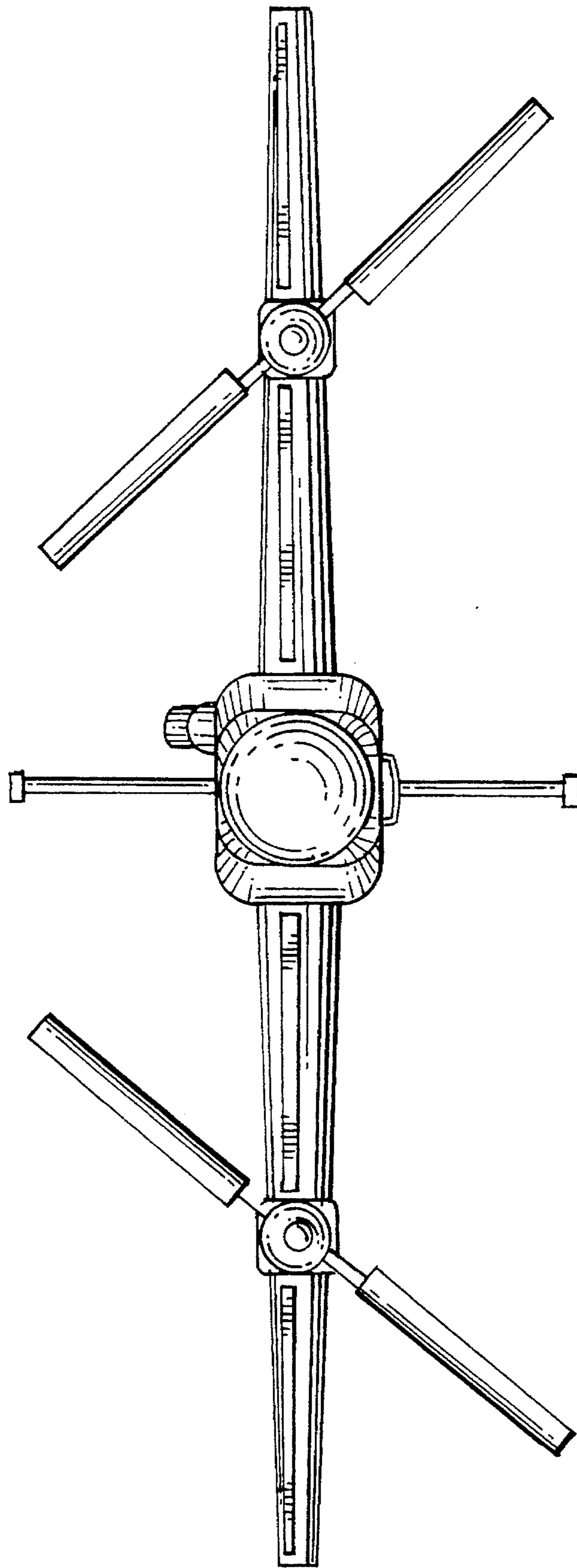

Fig. 4



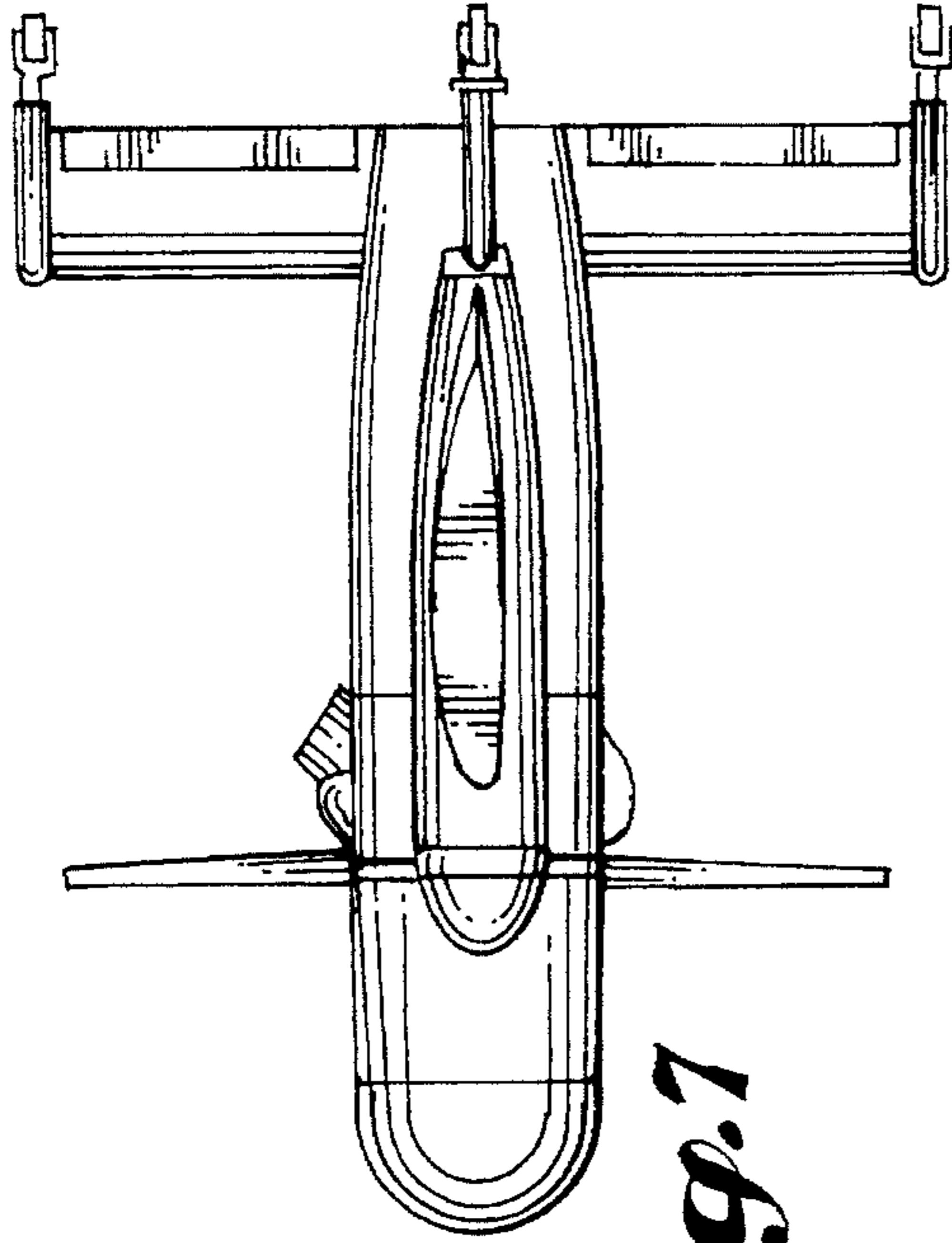

Fig. 7

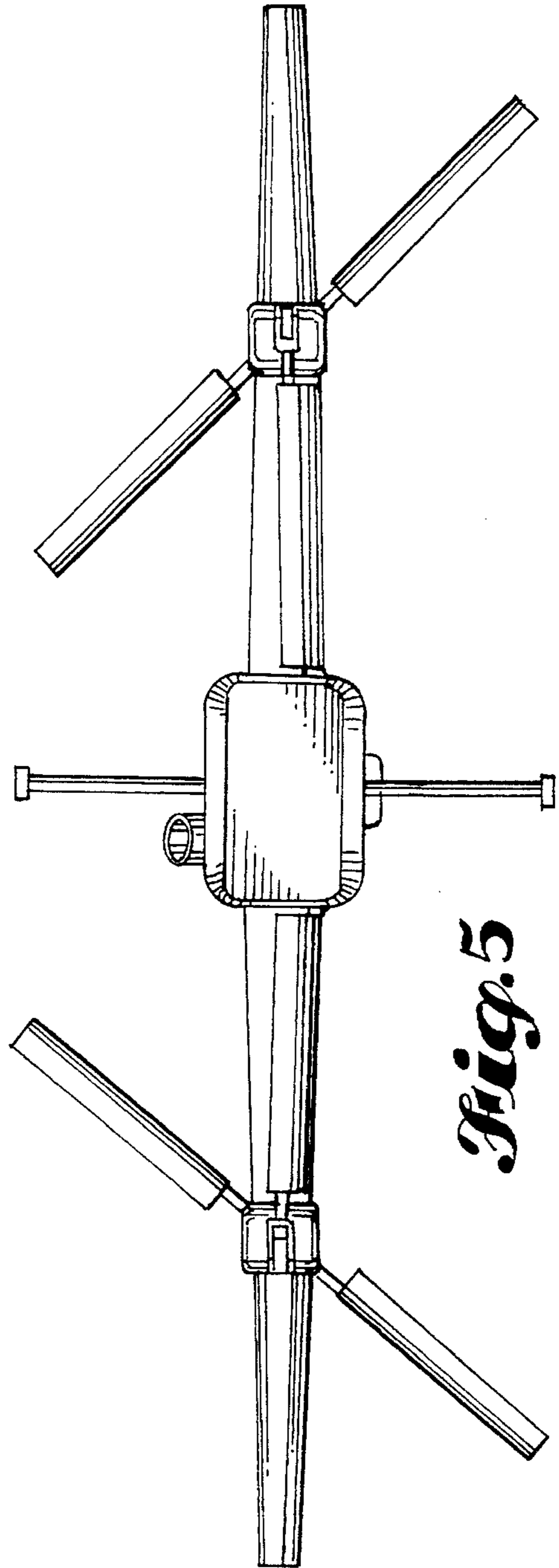

Fig. 5

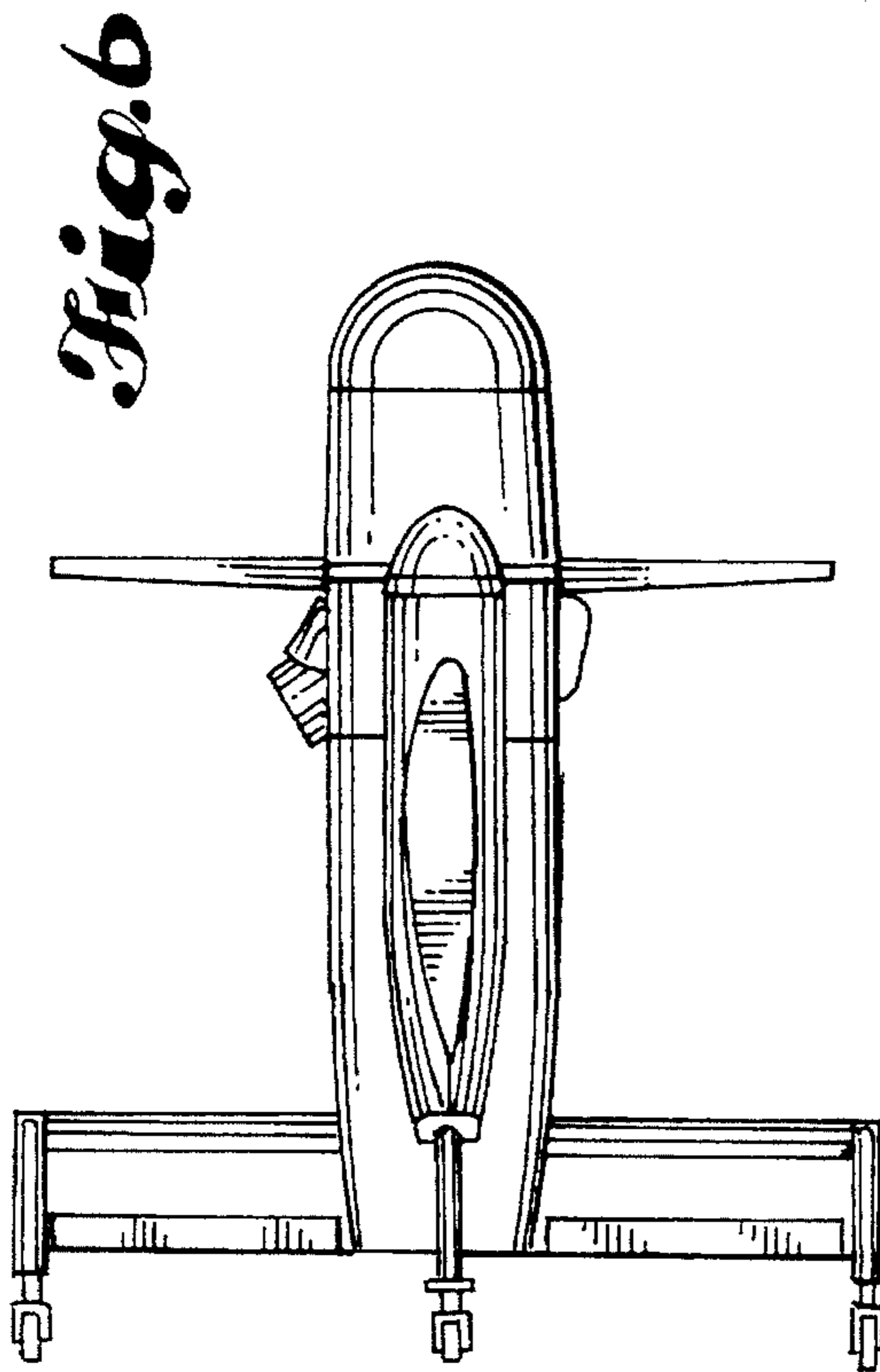

Fig. 6