



US00D367248S

United States Patent [19] Christensen

[11] Patent Number: **Des. 367,248**

[45] Date of Patent: ****Feb. 20, 1996**

[54] **TRAILER COVER**

[76] Inventor: **Carl E. Christensen**, 2415 149th Ave. NE., Ham Lake, Minn. 55304

[**] Term: **14 Years**

[21] Appl. No.: **29,521**

[22] Filed: **Oct. 7, 1994**

[52] U.S. Cl. **D12/102**

[58] Field of Search D12/102, 7; 296/165, 296/156, 22, 168, 24.1, 181; 280/204, 656

[56] **References Cited**

U.S. PATENT DOCUMENTS

D. 232,817	9/1974	Watson	D12/7
D. 265,301	7/1982	Zander	D12/102
D. 272,525	7/1984	Paulina	D12/102
D. 272,996	3/1984	Trabue et al.	D12/102
D. 329,215	9/1992	Alexander et al.	D12/102
4,537,441	8/1985	McCleary	D12/102

OTHER PUBLICATIONS

Triton Corporation, Allenton, Wisconsin, brochure copyright 1994.
Eagle Trailers, L & H Manufacturing, Inc., Fairmont, Min-

nesota, brochure published on or before Oct. 7, 1994.

Primary Examiner—A. Hugo Word
Assistant Examiner—M. Brown
Attorney, Agent, or Firm—Nawrocki, Rooney & Sivertson

[57] **CLAIM**

The ornamental design for a trailer cover, as shown and described.

DESCRIPTION

FIG. 1 is a perspective view of a trailer cover showing my new design;

FIG. 2 is a left side elevational view thereof with the right side being a mirror image;

FIG. 3 is a top plan view thereof;

FIG. 4 is a front elevational view thereof;

FIG. 5 is a rear elevational view thereof; and,

FIG. 6 is a bottom plan view.

The broken lines shown in FIG. 1 are for illustrative purposes only and form no part of the claimed design.

1 Claim, 3 Drawing Sheets

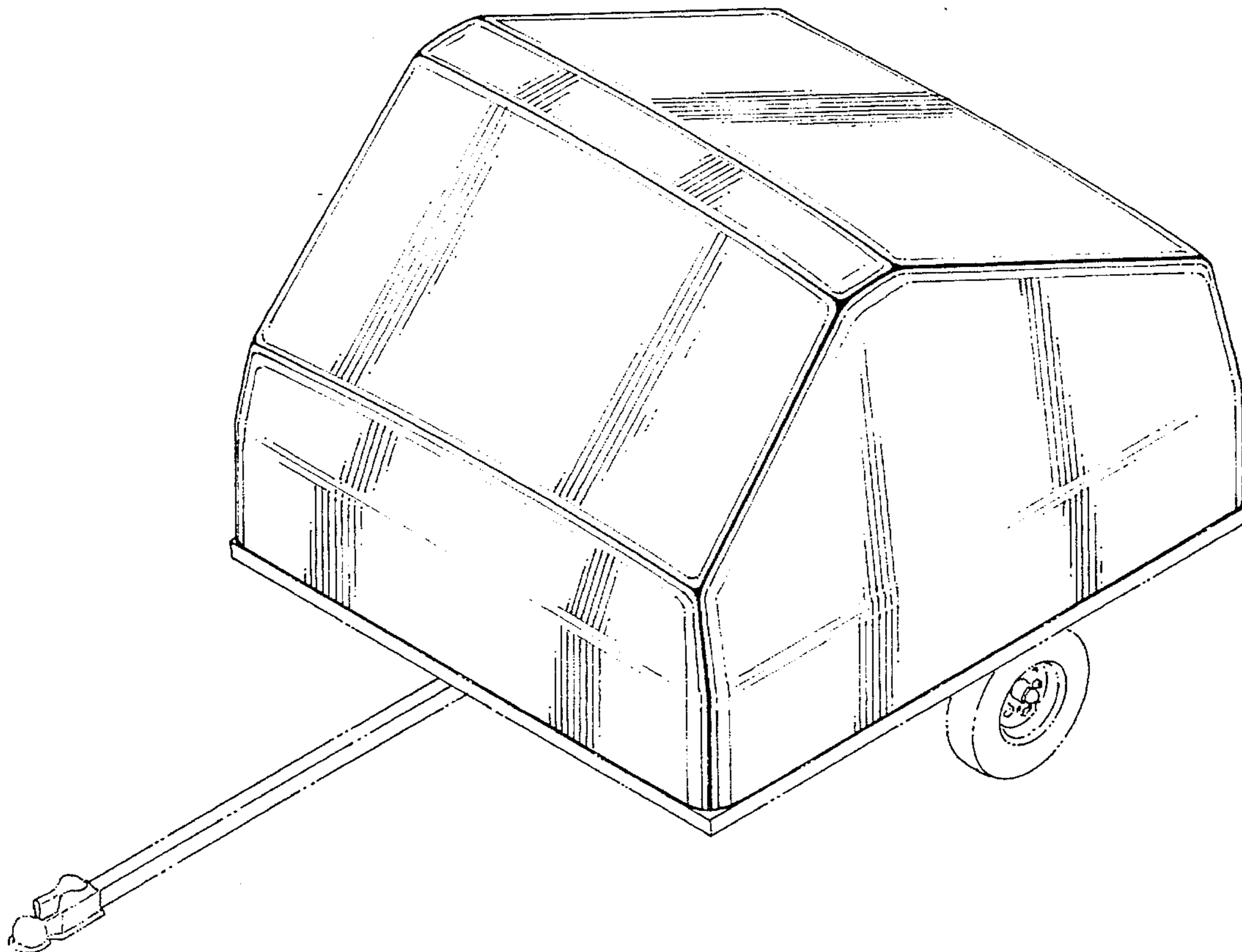

Fig. 1

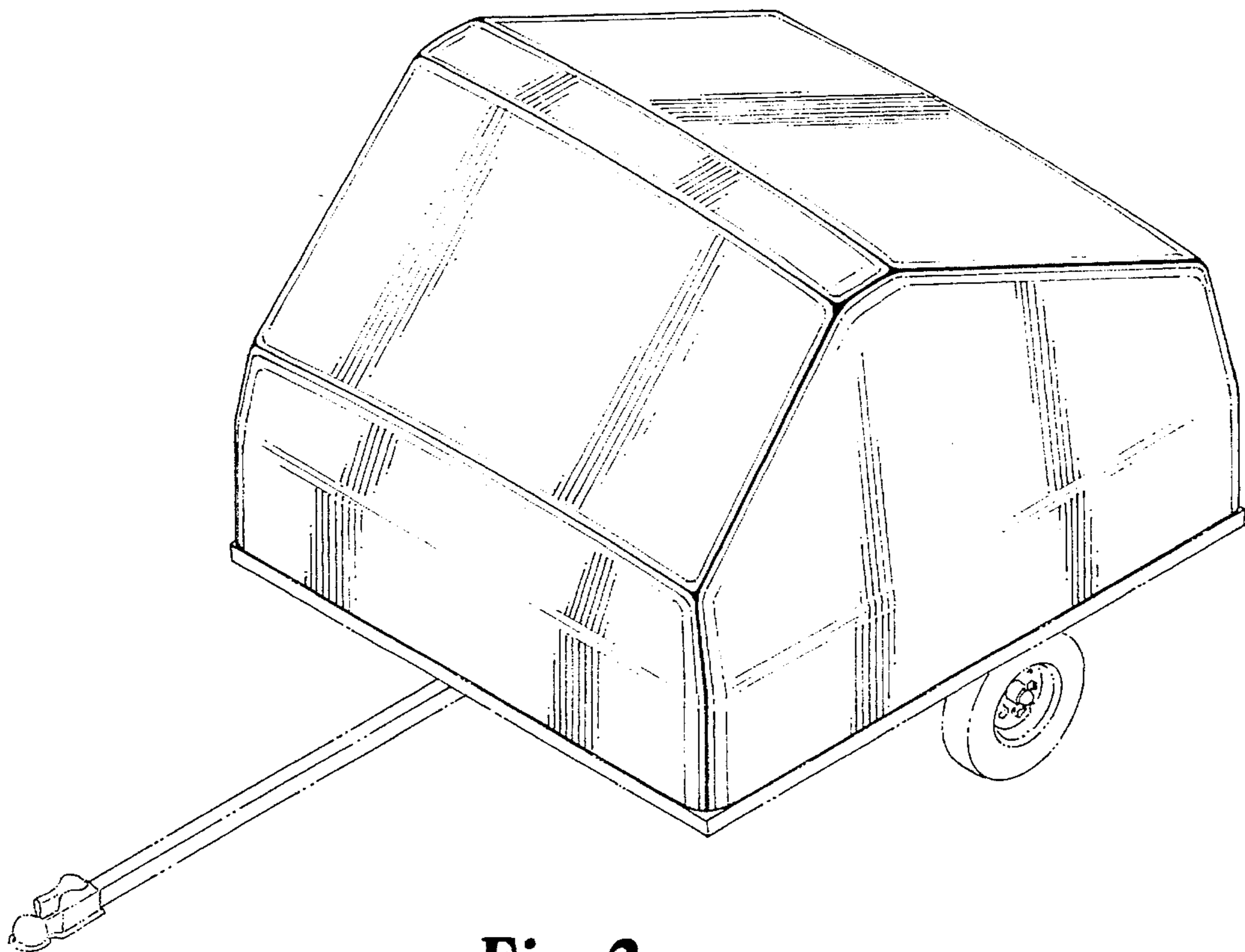

Fig. 2

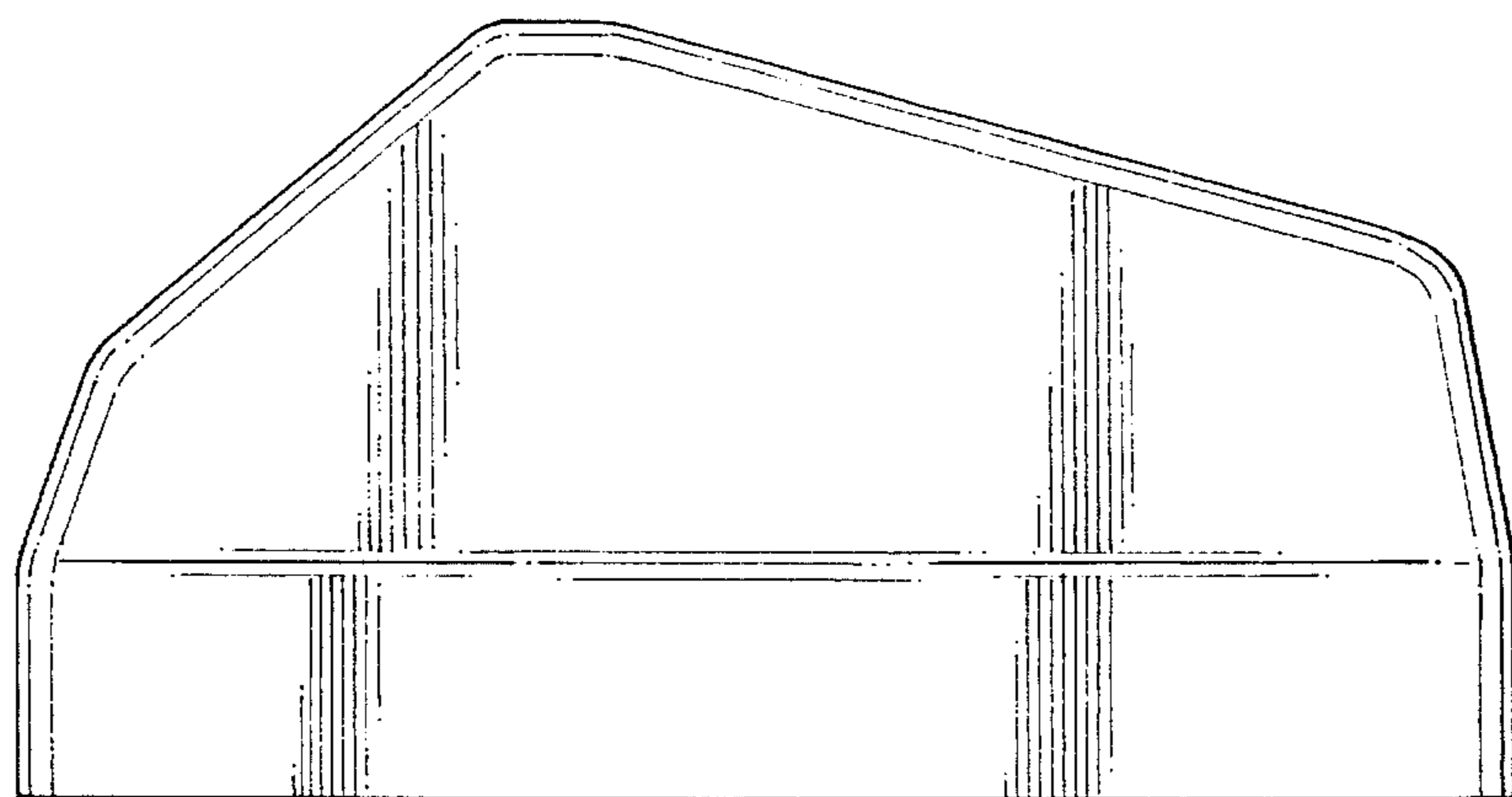

Fig. 3

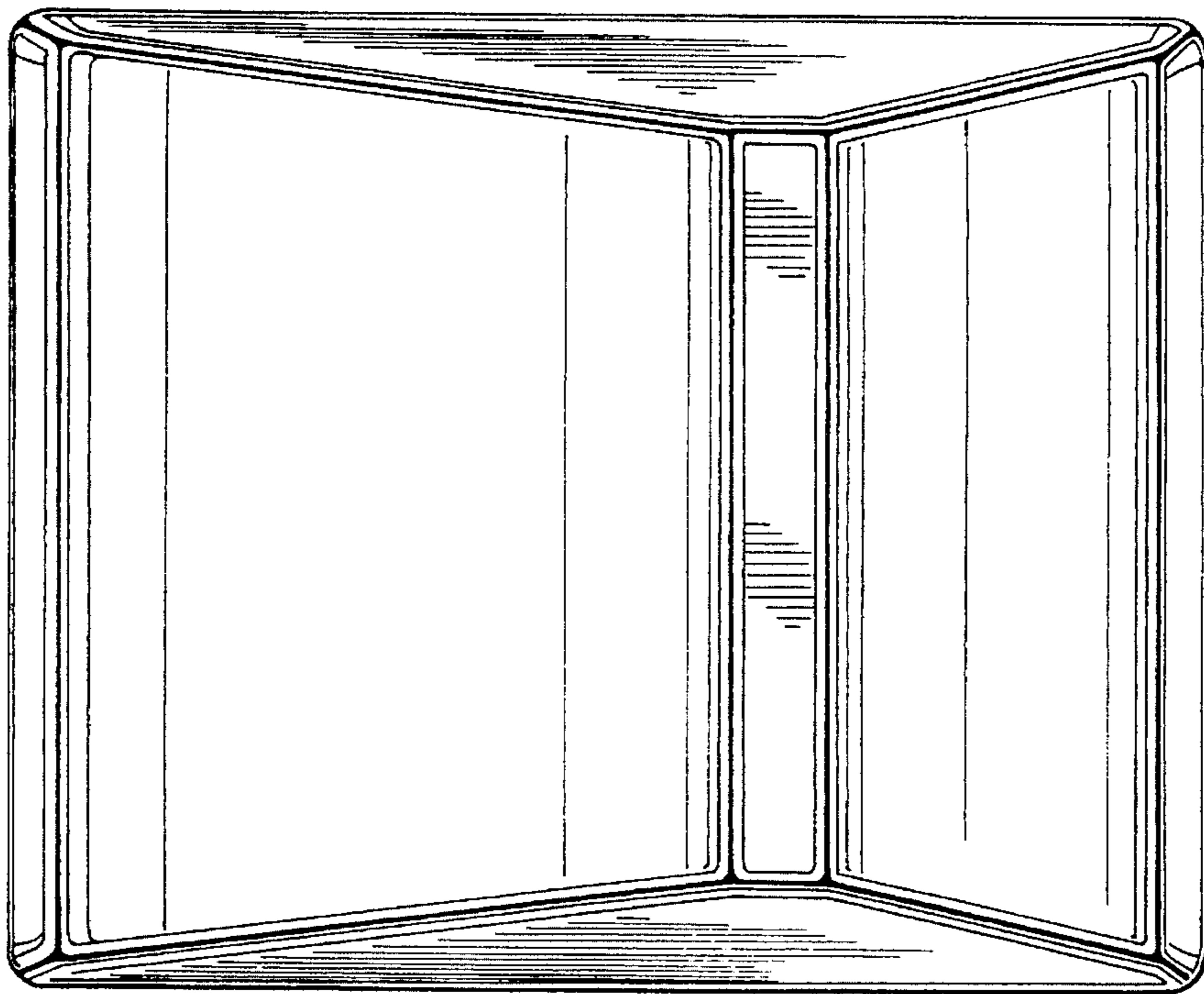

Fig. 4

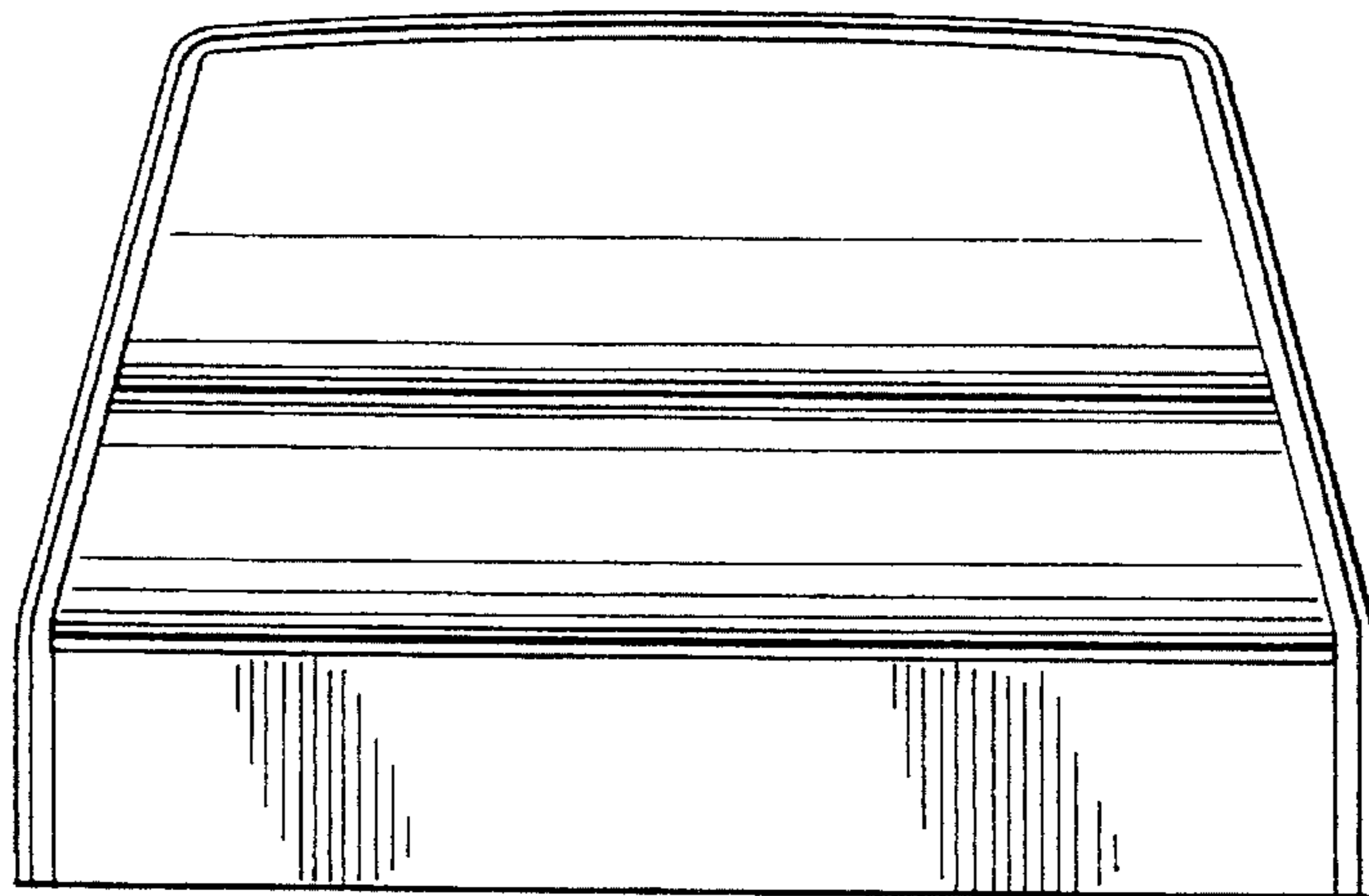

Fig. 5

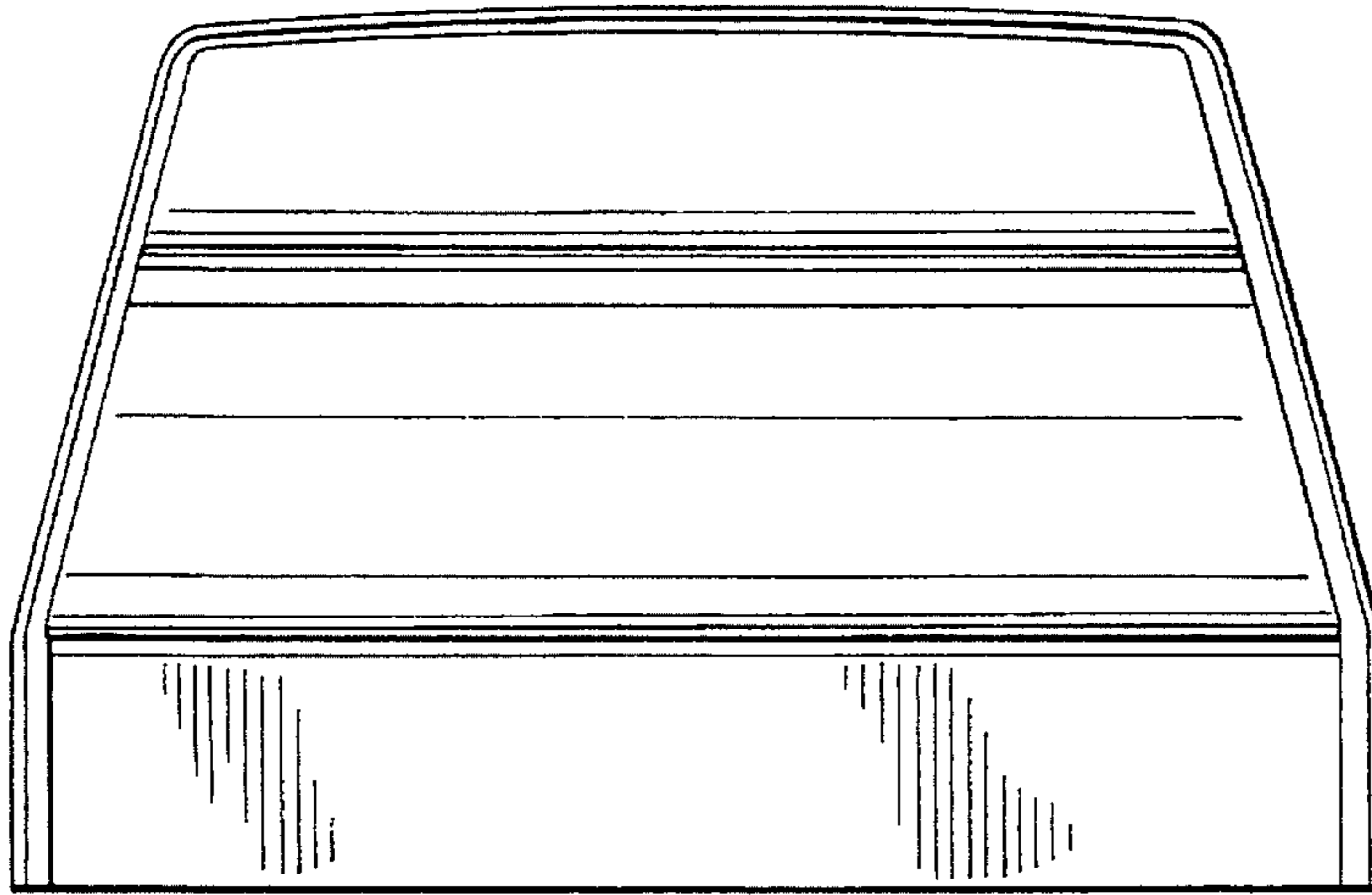

Fig. 6

