



US00D367070S

United States Patent [19]

[11] Patent Number: **Des. 367,070**

Maeda et al.

[45] Date of Patent: ****Feb. 13, 1996**

[54] INTERNAL COMBUSTION ENGINE

D. 330,897 11/1992 Carlson et al. D15/3

[75] Inventors: **Joji Maeda; Masahiro Anzai**, both of Wako, Japan

D. 331,929 12/1992 Leaf et al. D15/1

D. 353,381 12/1994 Yoshida et al. D15/1

[73] Assignee: **Honda Giken Kogyo Kabushiki Kaisha**, Tokyo, Japan

Primary Examiner—Ralf Seifert
Attorney, Agent, or Firm—Schwartz & Weintrieb

[**] Term: **14 Years**

[57] **CLAIM**

The ornamental design for an internal combustion engine, as shown.

[21] Appl. No.: **32,769**

[22] Filed: **Dec. 27, 1994**

DESCRIPTION

[30] **Foreign Application Priority Data**

FIG. 1 is a right side perspective view of an internal combustion engine showing our new design;

FIG. 2 is a front perspective view thereof;

FIG. 3 is a front elevational view thereof;

FIG. 4 is a rear elevational view thereof;

FIG. 5 is a left side elevational view thereof;

FIG. 6 is a right side elevational view thereof;

FIG. 7 is a top plan view thereof; and,

FIG. 8 is a bottom plan view thereof.

Jun. 24, 1994 [JP] Japan 6-18467

[52] U.S. Cl. **D15/1**

[58] Field of Search D15/1-6; 123/50 A, 123/50 B, 50 R, 51 R, 51 A, 51 B, 65 R, 70 R, 51 BD, 65 P, 65 PD, 65 PE

[56] **References Cited**

U.S. PATENT DOCUMENTS

D. 307,147 4/1990 Sacaki et al. D15/1

1 Claim, 4 Drawing Sheets

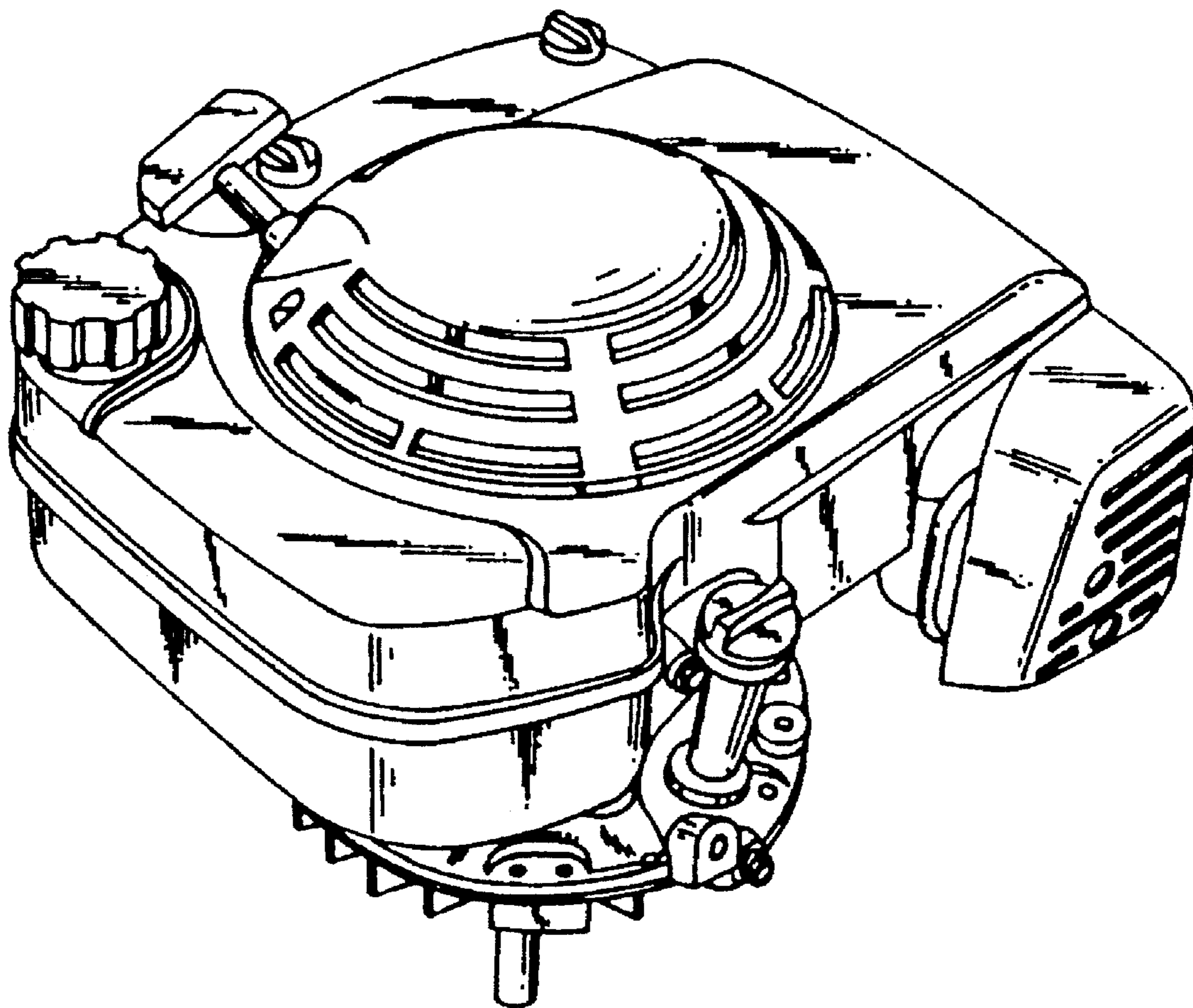

FIG. 1

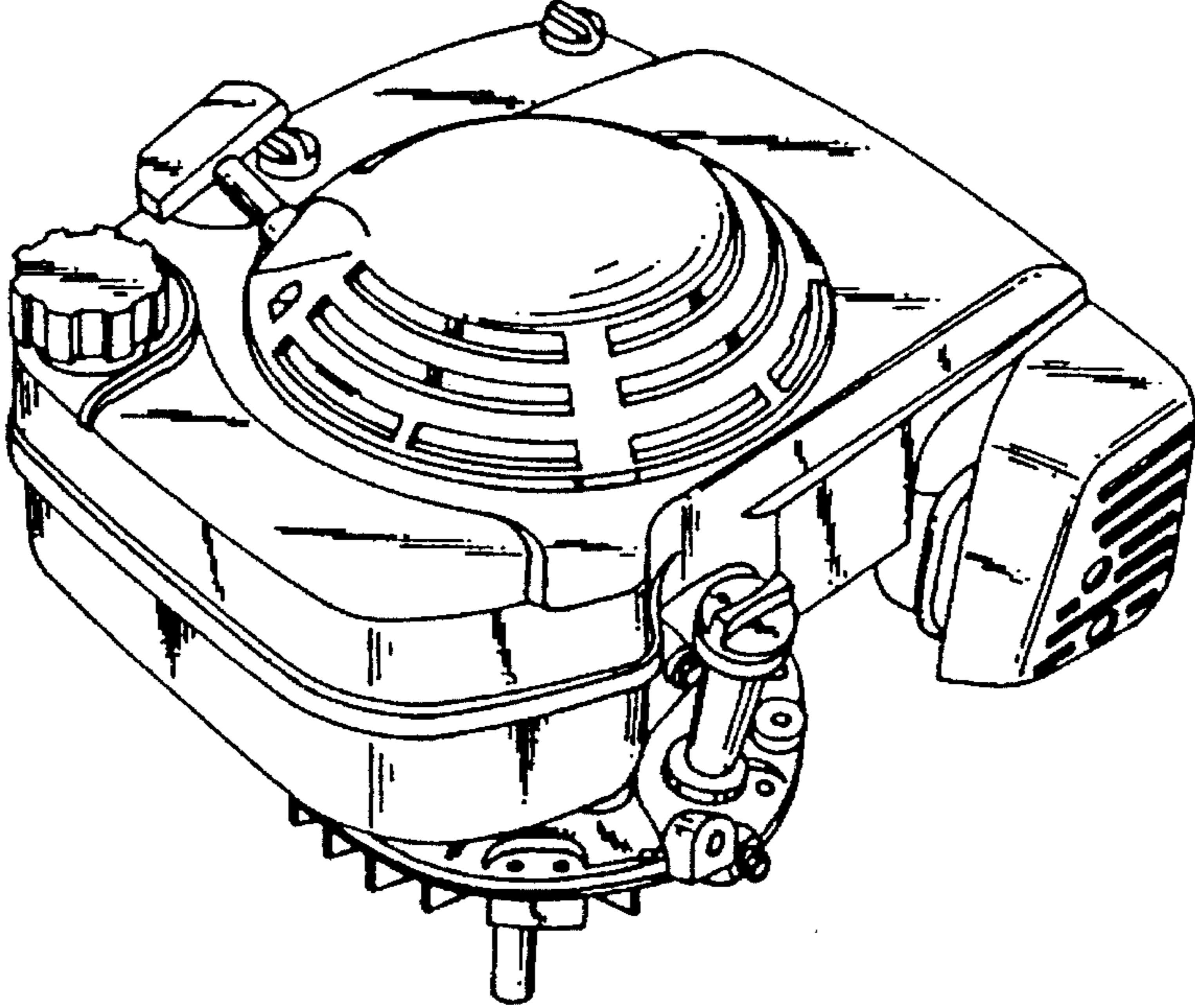

FIG. 2

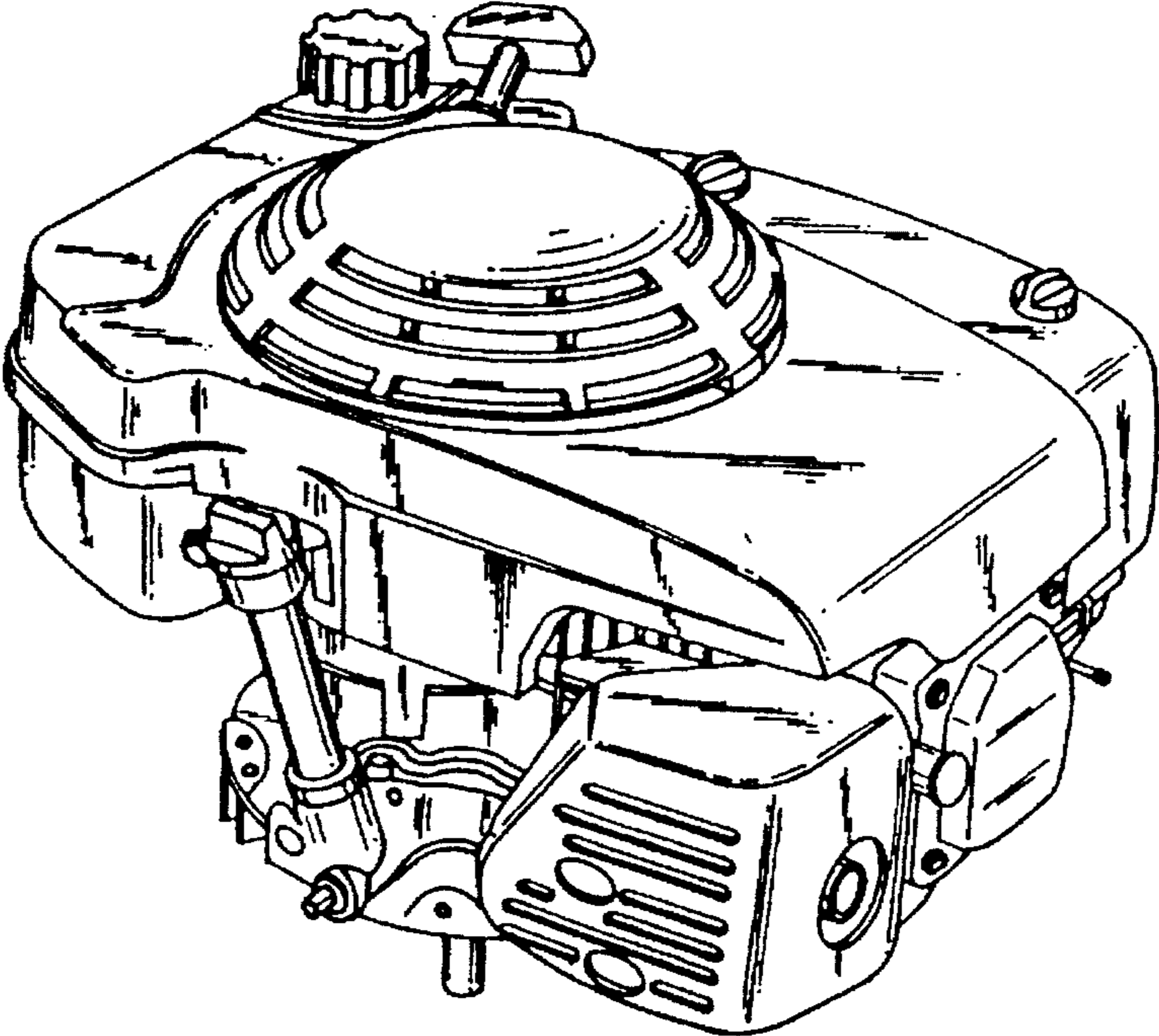

FIG. 3

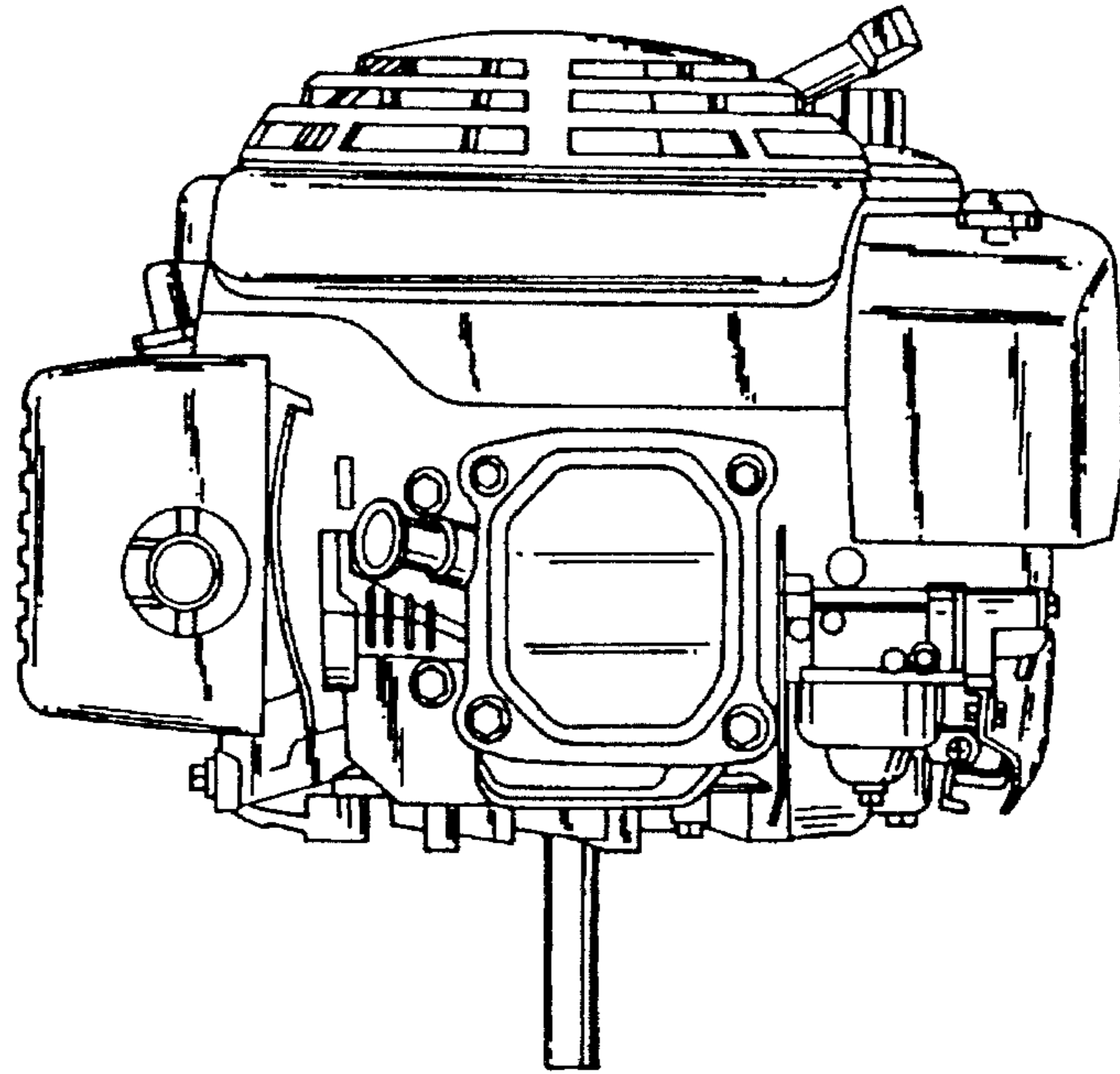

FIG. 4

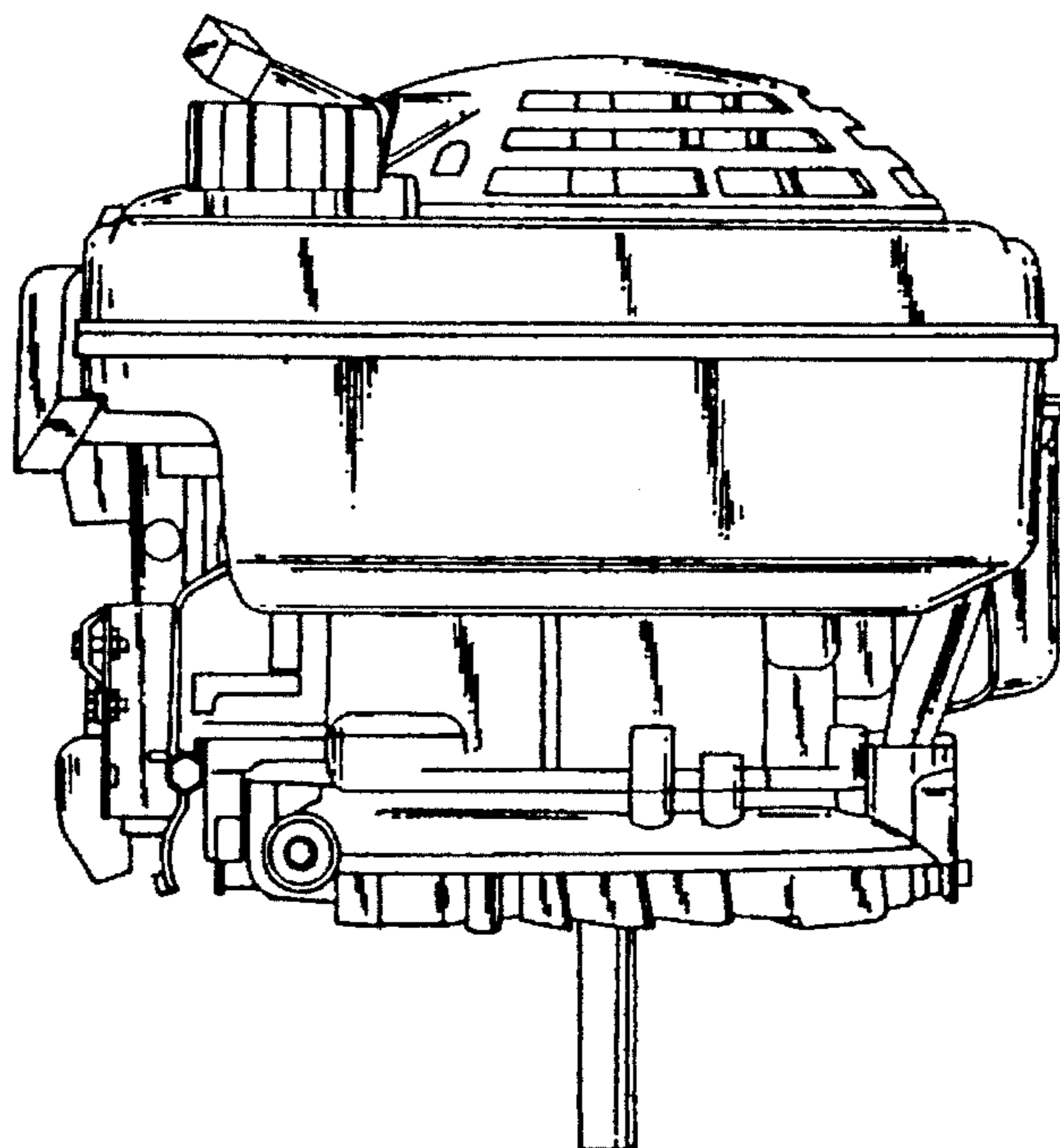

FIG. 5

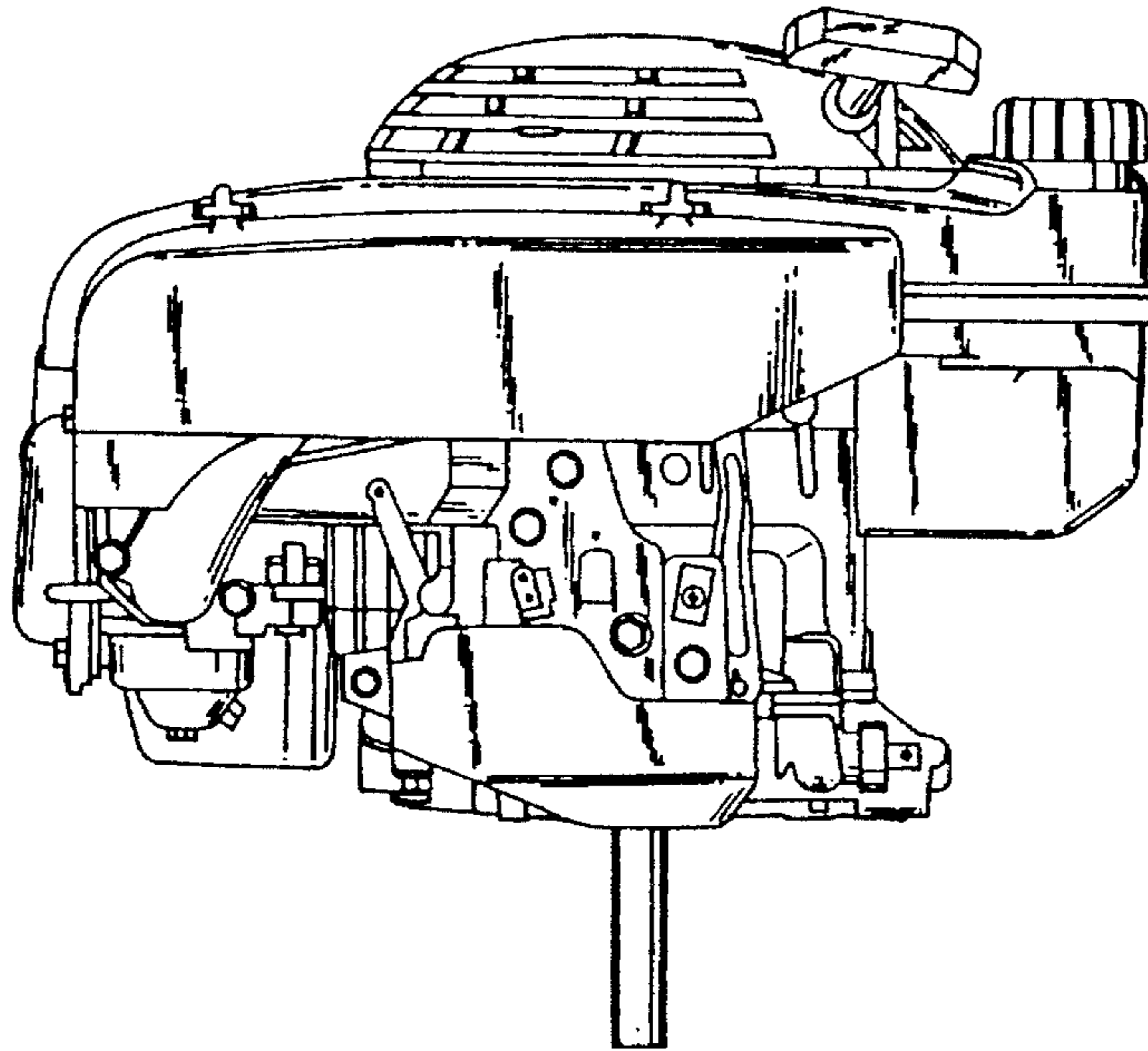

FIG. 6

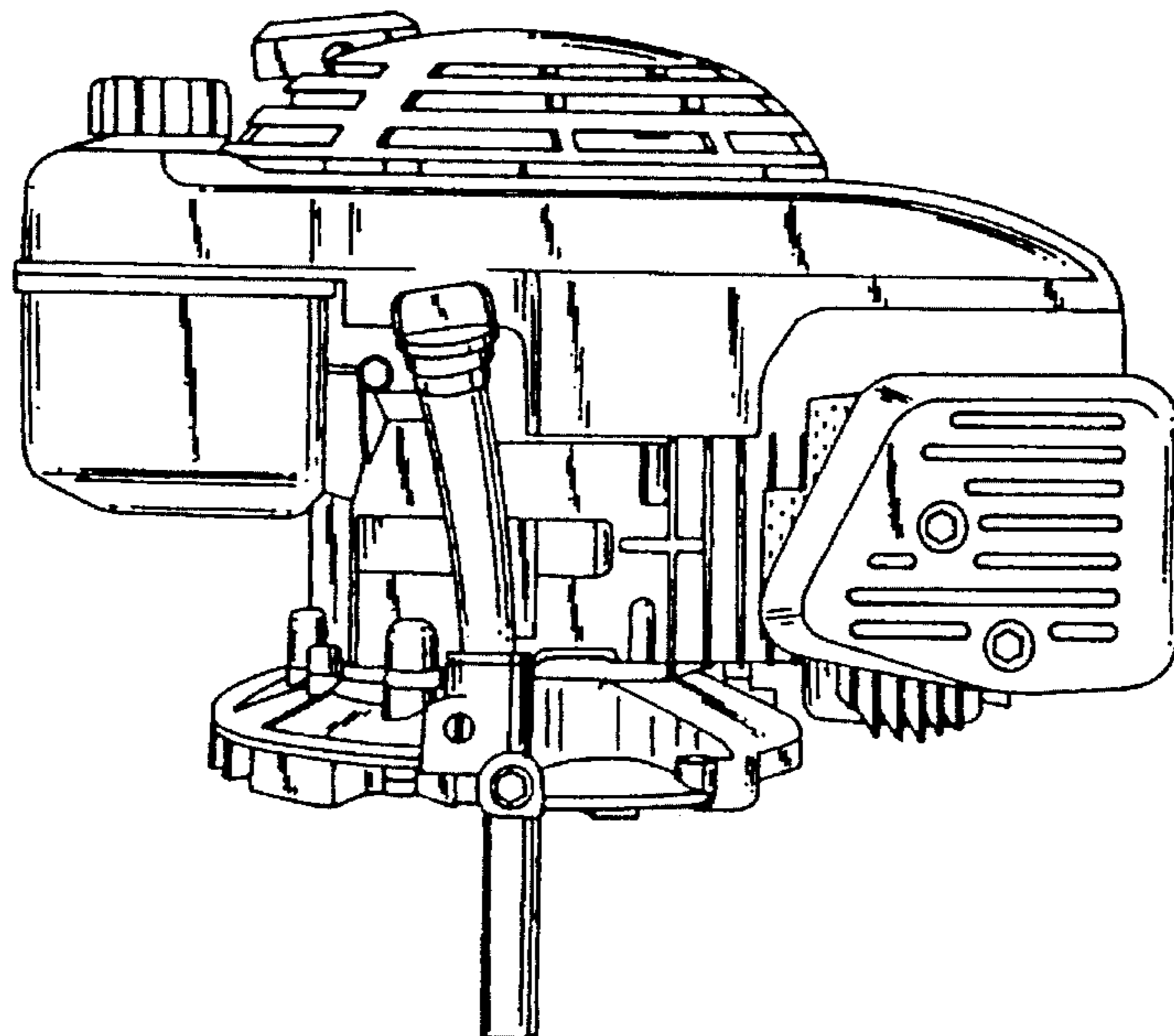

FIG. 7

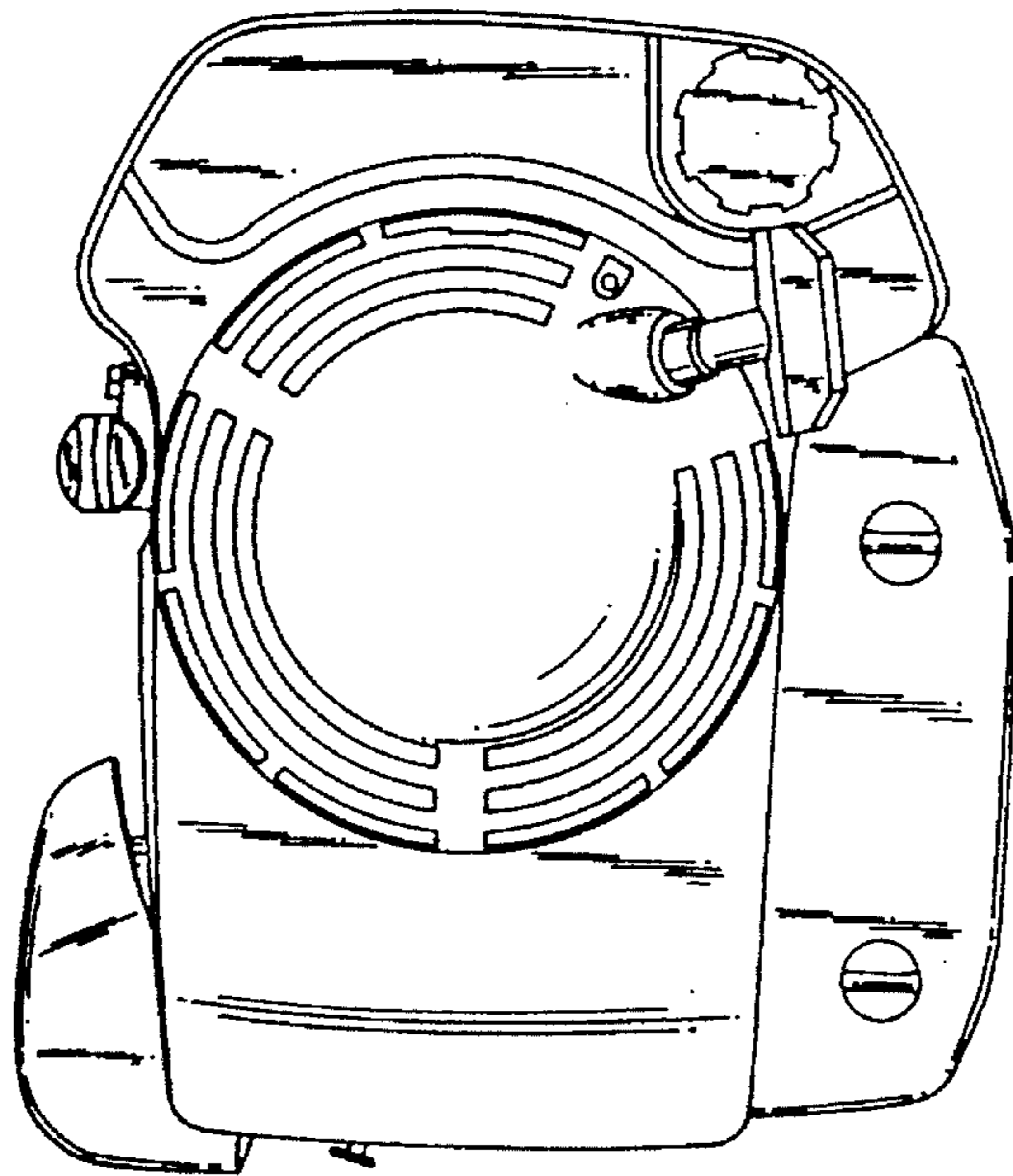

FIG. 8

