



US00D367027S

United States Patent [19]
Onopa

[11] **Patent Number: Des. 367,027**

[45] **Date of Patent: **Feb. 13, 1996**

[54] **TRUCK HOOD AND BUMPER**

[75] Inventor: **David P. Onopa**, Allentown, Pa.

[73] Assignee: **Mack Trucks, Inc.**, Allentown, Pa.

[**] Term: **14 Years**

[21] Appl. No.: **29,045**

[22] Filed: **Sep. 28, 1994**

[52] U.S. Cl. **D12/173**

[58] Field of Search **D12/173, 96, 97;**
296/190

[56] **References Cited**

U.S. PATENT DOCUMENTS

D. 291,982	9/1987	Simons et al.	D12/96
D. 306,714	3/1990	Allendorph	D12/173
D. 312,805	12/1990	Marlowe et al.	D12/96
D. 335,272	5/1993	Allendorph et al.	D12/173

OTHER PUBLICATIONS

- "Commercial Carrier Journal", Jul. 1992, p. 28.
- "Commercial Carrier Journal", Feb. 1987, p. 97.
- "Commercial Carrier Journal", Apr. 1992, p. 57, front-most

truck hood.

"Commercial Carrier Journal", Apr. 1993, p. 98.

Primary Examiner—Janice E. Seeger

Assistant Examiner—Cathron B. Matta

Attorney, Agent, or Firm—Rothwell, Figg, Ernst & Kurz

[57] **CLAIM**

The ornamental design of a truck hood and bumper, as shown and described.

DESCRIPTION

FIG. 1 is a perspective view showing my new design, it being understood that the broken lines are for illustrative purposes only and form no part of the design;

FIG. 2 is a side elevation view of the embodiment shown in FIG. 1, it being understood that the broken lines are for illustrative purposes only and form no part of the design; and,

FIG. 3 is a front elevation view of the embodiment shown in FIGS. 1 and 2, it being understood that the broken lines are for illustrative purposes only and form no part of the design.

1 Claim, 3 Drawing Sheets

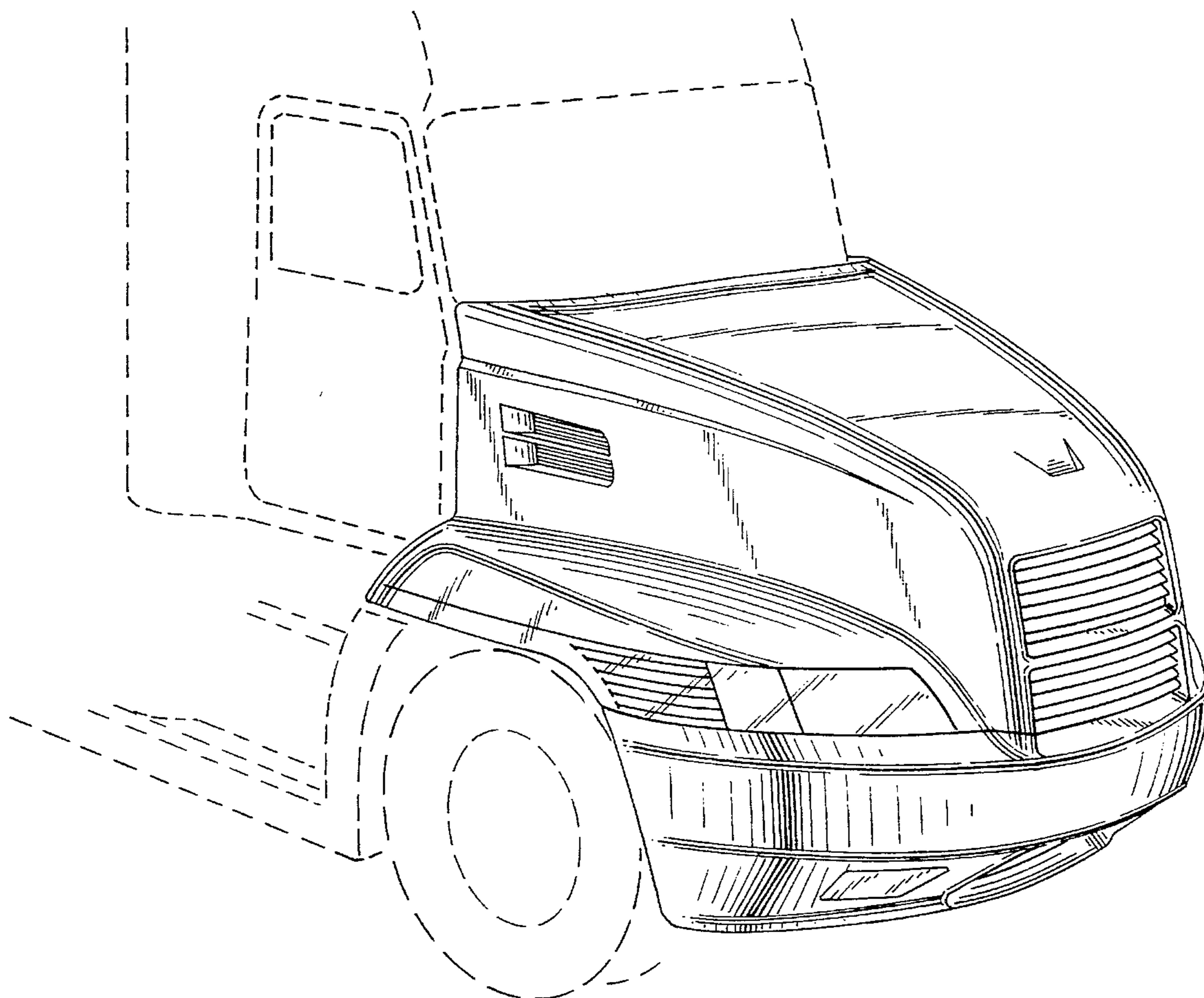
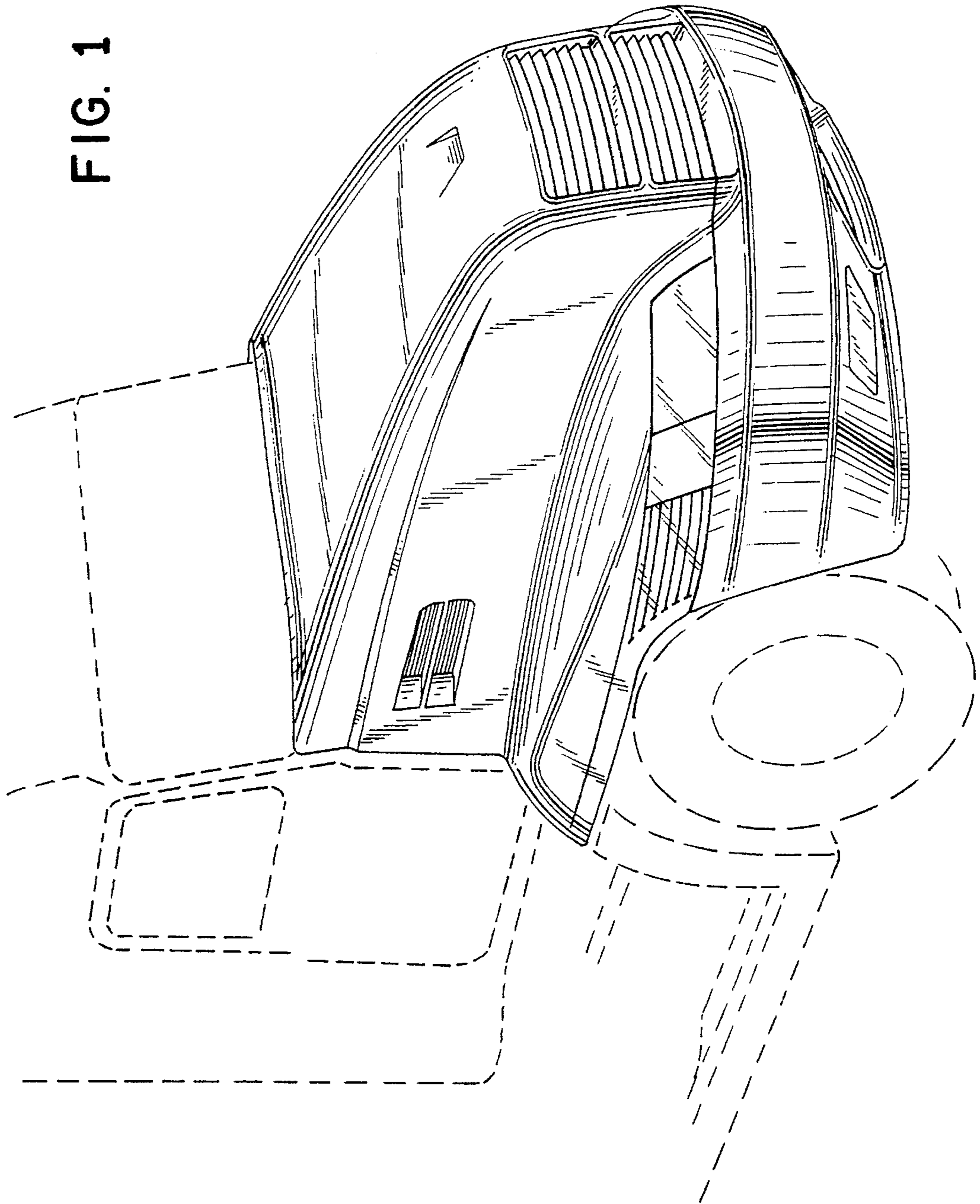

FIG. 1



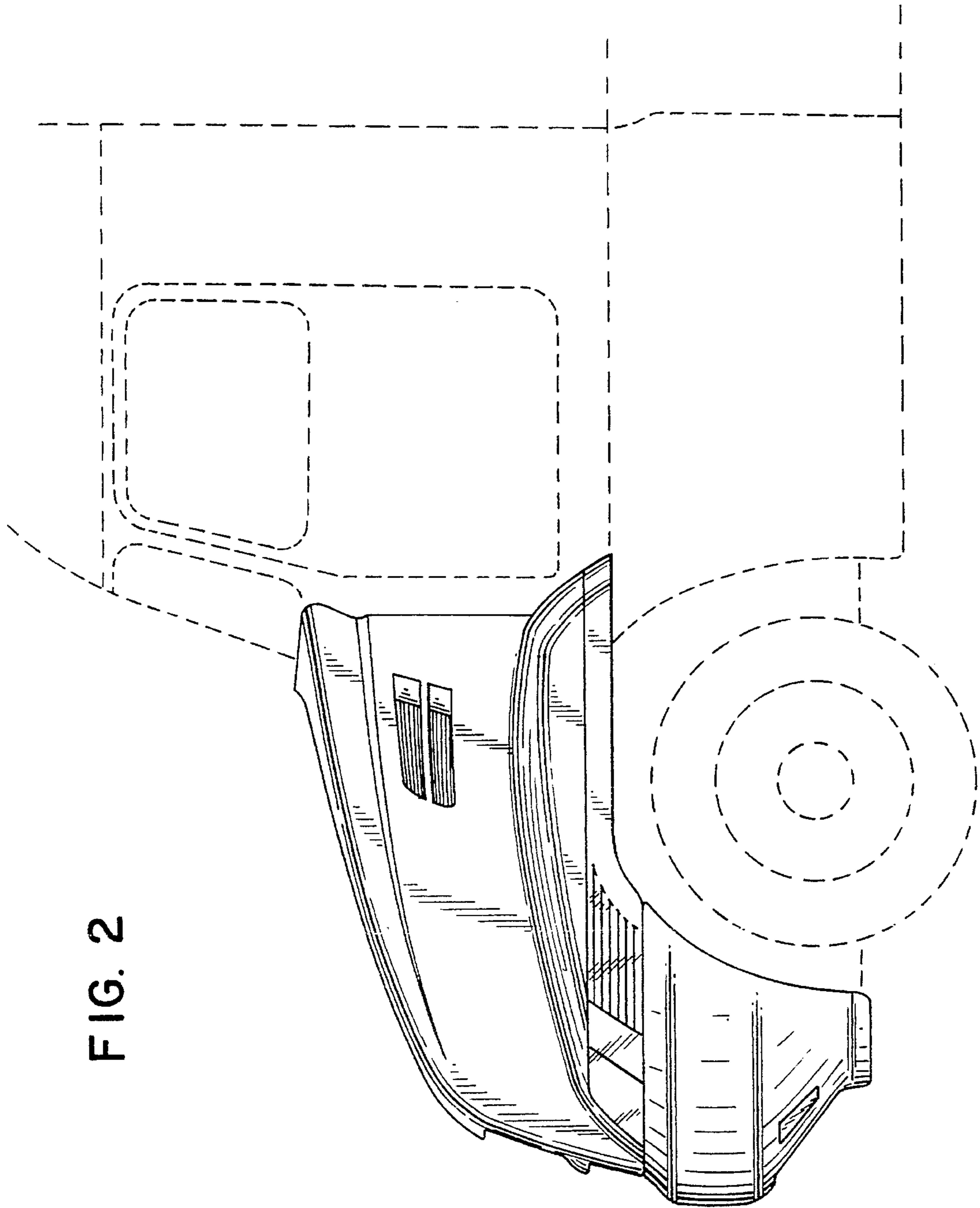

FIG. 2

FIG. 3

