



US00D367022S

United States Patent [19] Graber

[11] Patent Number: **Des. 367,022**

[45] Date of Patent: ****Feb. 13, 1996**

[54] **BICYCLE RACK**

[75] Inventor: **Thomas L. Graber**, Middleton, Wis.

[73] Assignee: **Madrax, Inc.**, Middleton, Wis.

[**] Term: **14 Years**

[21] Appl. No.: **36,035**

[22] Filed: **Mar. 10, 1995**

[52] U.S. Cl. **D12/115**

[58] Field of Search D12/115; D7/631-634;
211/5, 17-22, 198

[56] **References Cited**

U.S. PATENT DOCUMENTS

D. 245,596	8/1977	Cohen et al.	D12/115
D. 262,532	1/1982	Levine	D12/115
D. 269,000	5/1983	Girard	D12/115
D. 302,258	7/1989	Kalisch et al.	D12/115
D. 337,083	7/1993	Rankin	D12/115
D. 341,342	11/1993	Pook	D12/115
2,329,088	9/1943	Schram et al.	211/17
3,202,289	8/1965	Burditt	211/22
3,907,114	9/1975	Ewers	211/20
3,994,400	11/1976	Graber	211/22
4,306,660	12/1981	Livingston	211/20
5,098,155	3/1992	Graber	297/217

OTHER PUBLICATIONS

"Design News", Nov. 3, 1980, p. 32, Bicycle Ribbon Rack.

Primary Examiner—Alan P. Douglas
Assistant Examiner—Cathron B. Matta
Attorney, Agent, or Firm—Lathrop & Clark

[57] **CLAIM**

The ornamental design for a bicycle rack, as shown and described.

DESCRIPTION

FIG. 1 is a top plan view of a first embodiment of the bicycle rack of this invention;

FIG. 2 is a front elevational view thereof, the rear elevational view being identical thereto;

FIG. 3 is a left side elevational view thereof, the right side elevational view thereof being identical thereto;

FIG. 4 is an perspective view thereof;

FIG. 5 is an perspective view of an alternative embodiment bicycle rack of this invention;

FIG. 6 is a top plan view thereof;

FIG. 7 is a front elevational view thereof, the rear elevational view being identical thereto;

FIG. 8 is a left side elevational view thereof, the right side elevational view thereof being identical thereto;

FIG. 9 is a top plan view of another alternative embodiment bicycle rack of this invention;

FIG. 10 is a front elevational view thereof, the rear elevational view being identical thereto;

FIG. 11 is a left side elevational view thereof, the right side elevational view thereof being identical thereto;

FIG. 12 is a top plan view of yet another alternative embodiment bicycle rack of this invention;

FIG. 13 is a front elevational view thereof, the rear elevational view being identical thereto; and

FIG. 14 is a left side elevational view thereof, the right side elevational view thereof being identical thereto.

1 Claim, 8 Drawing Sheets

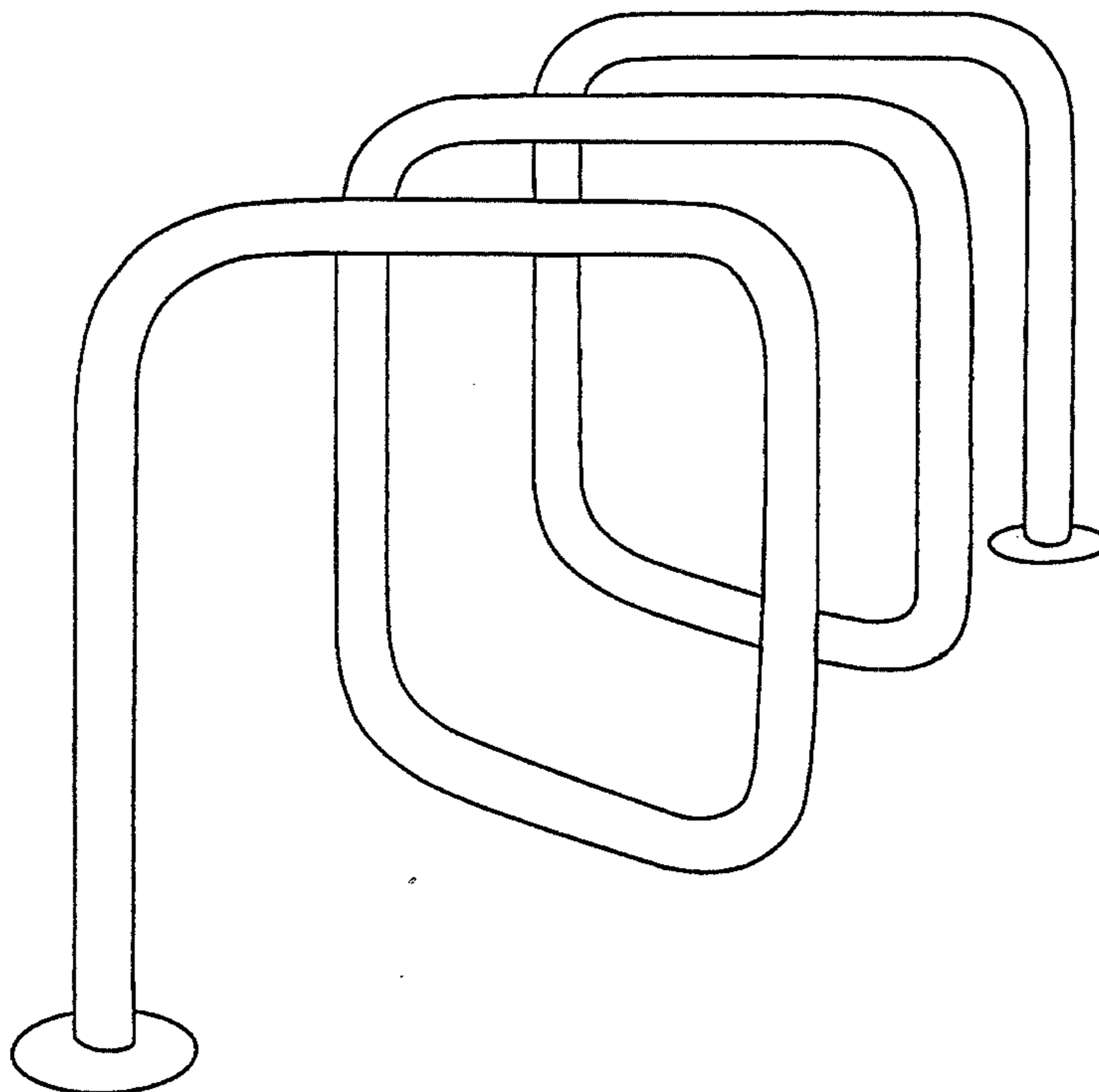

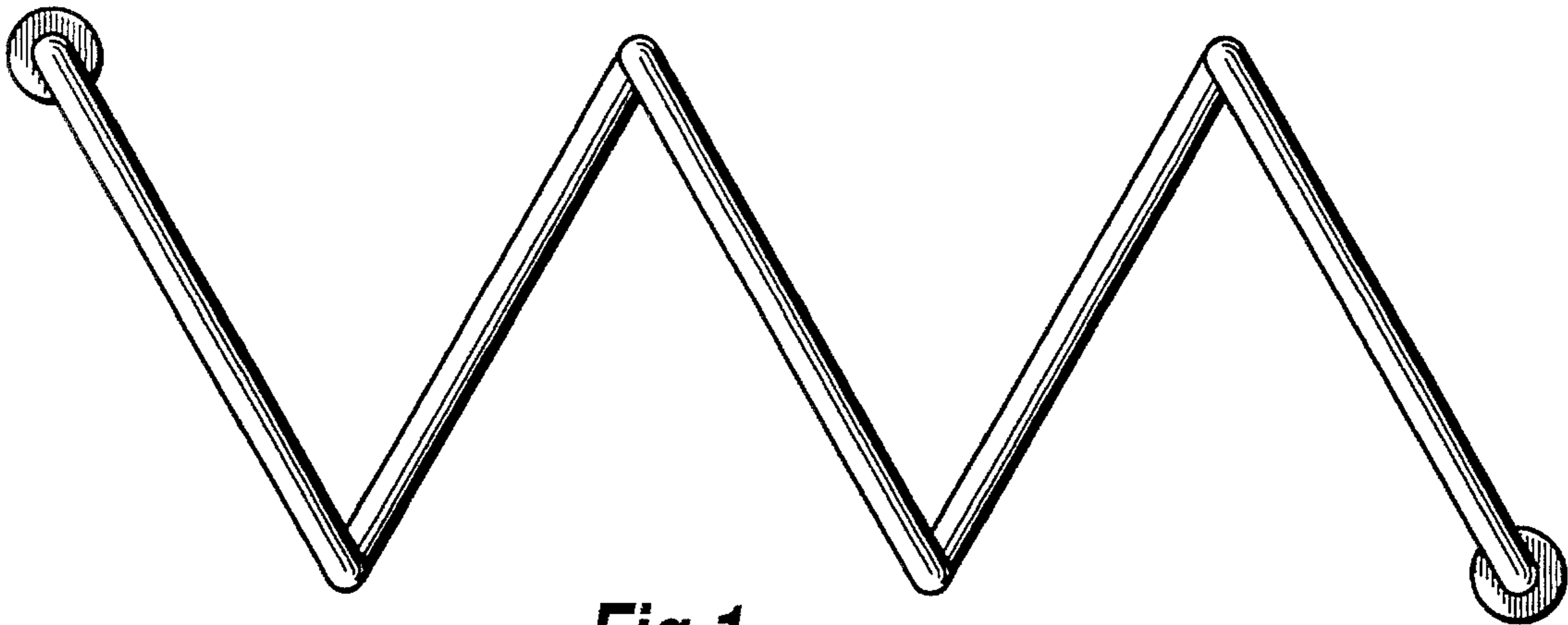

Fig.1

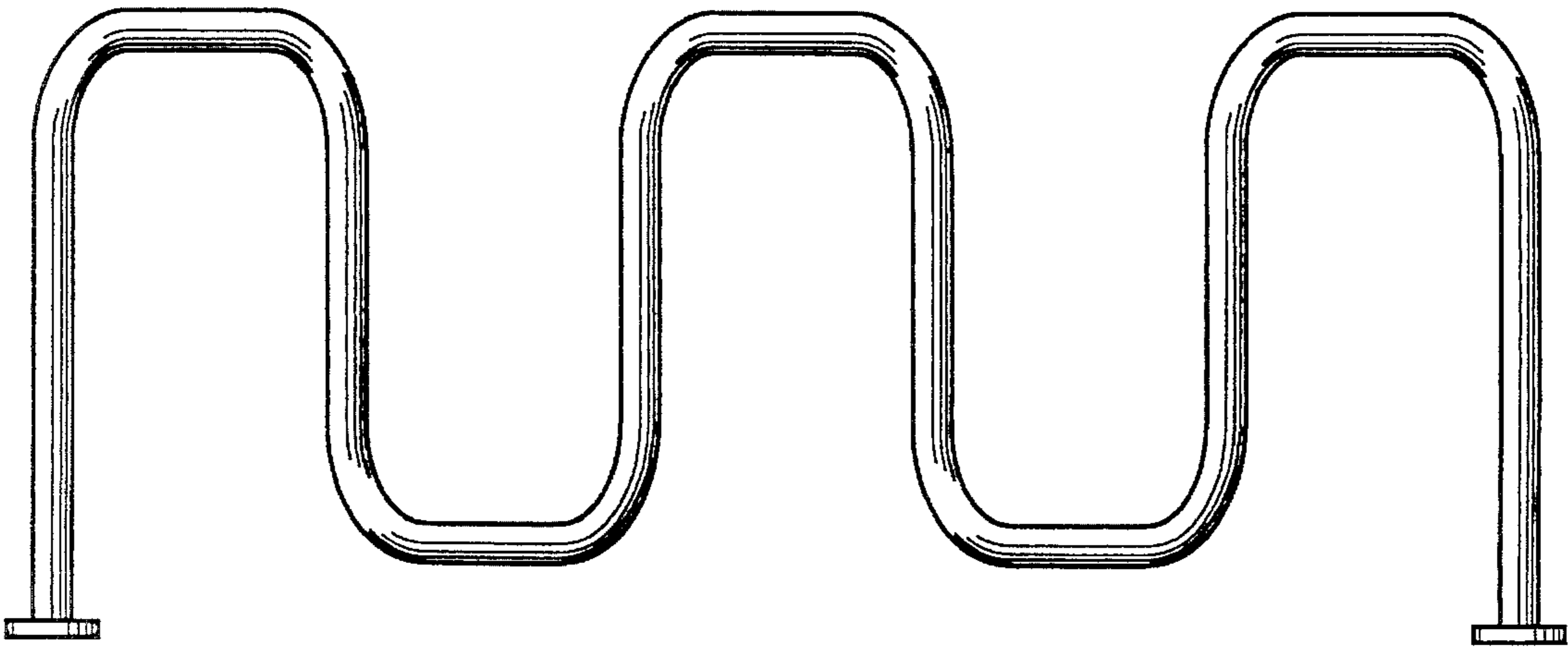

Fig.2

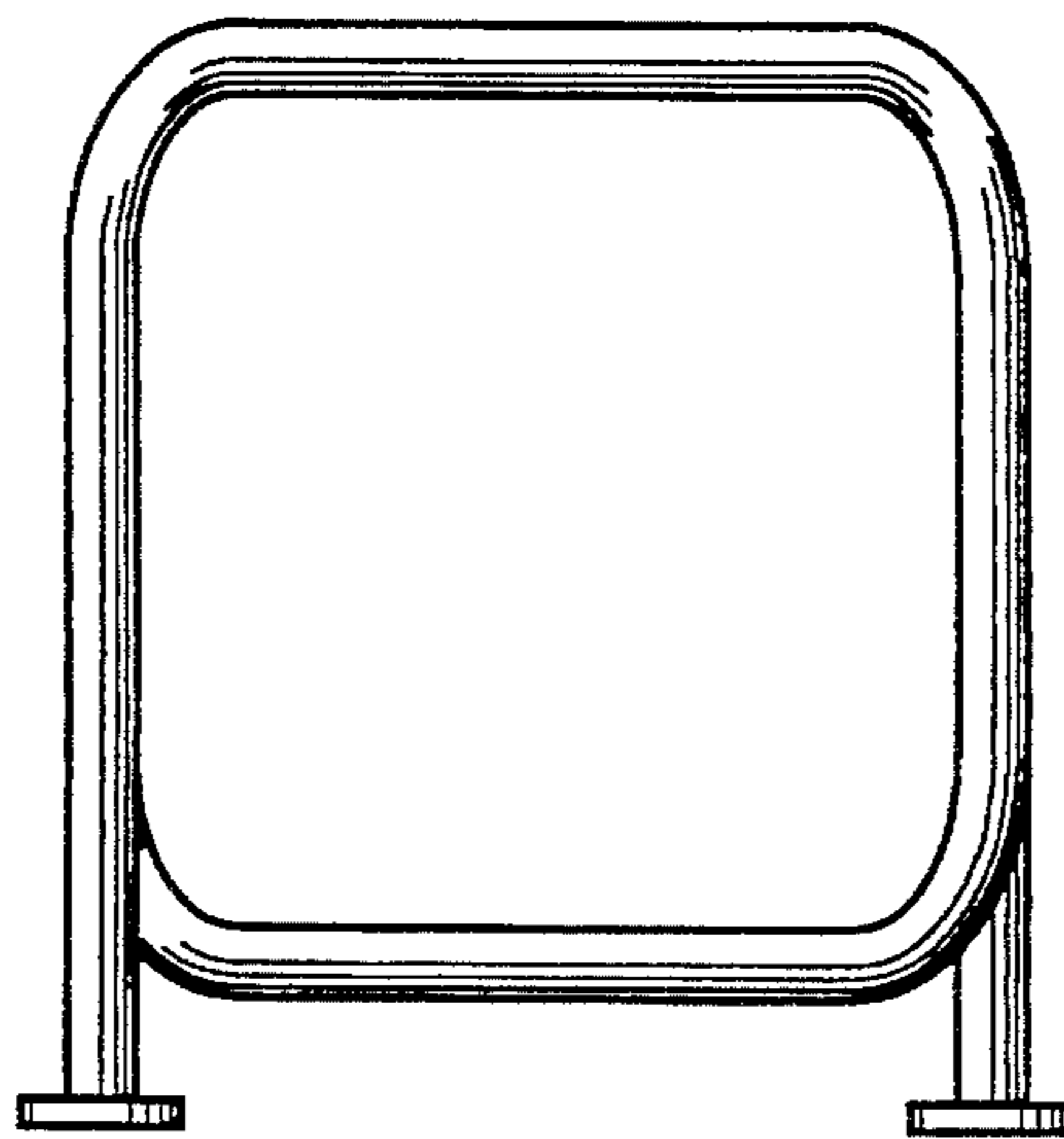

Fig.3

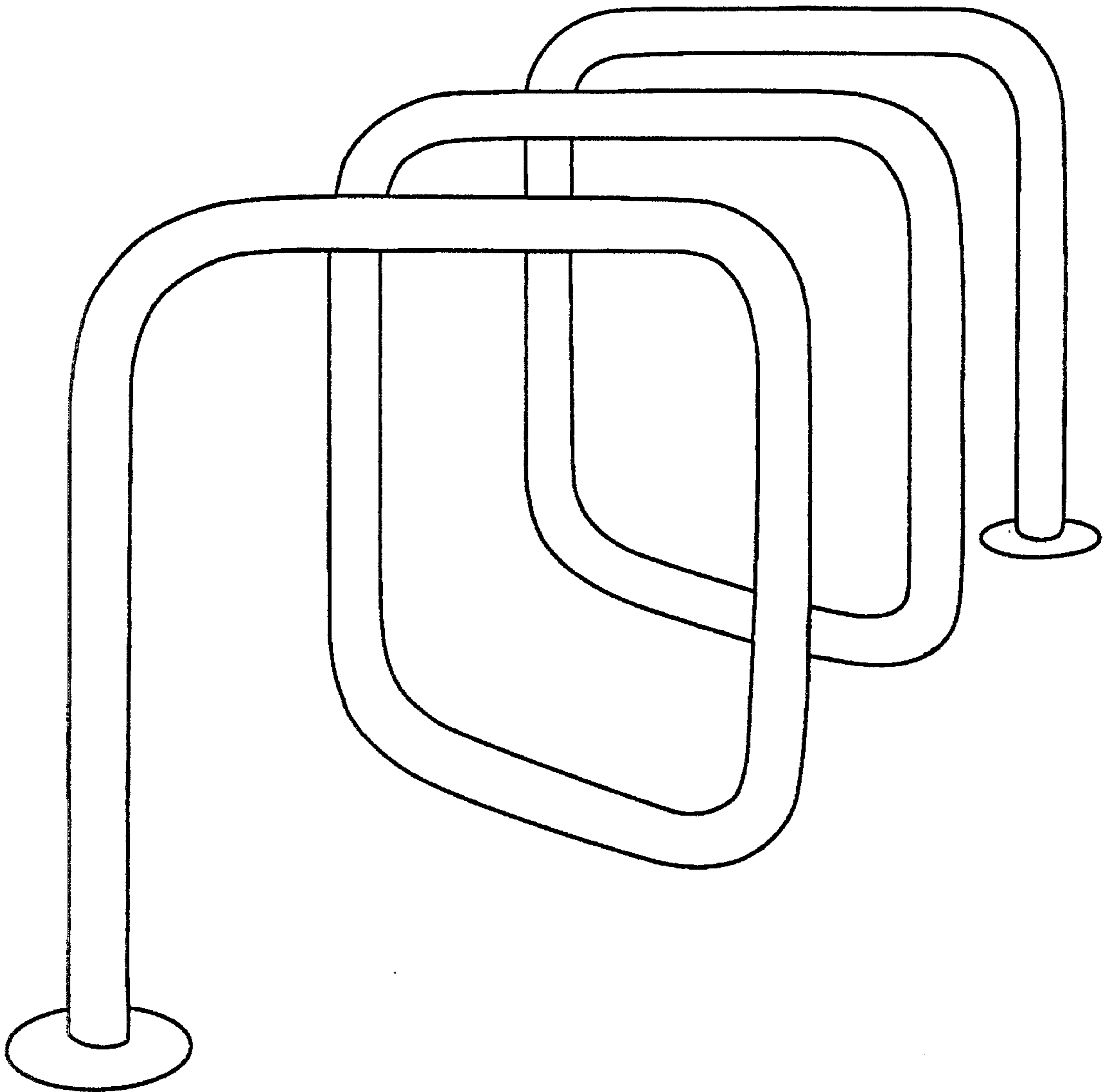

Fig.4

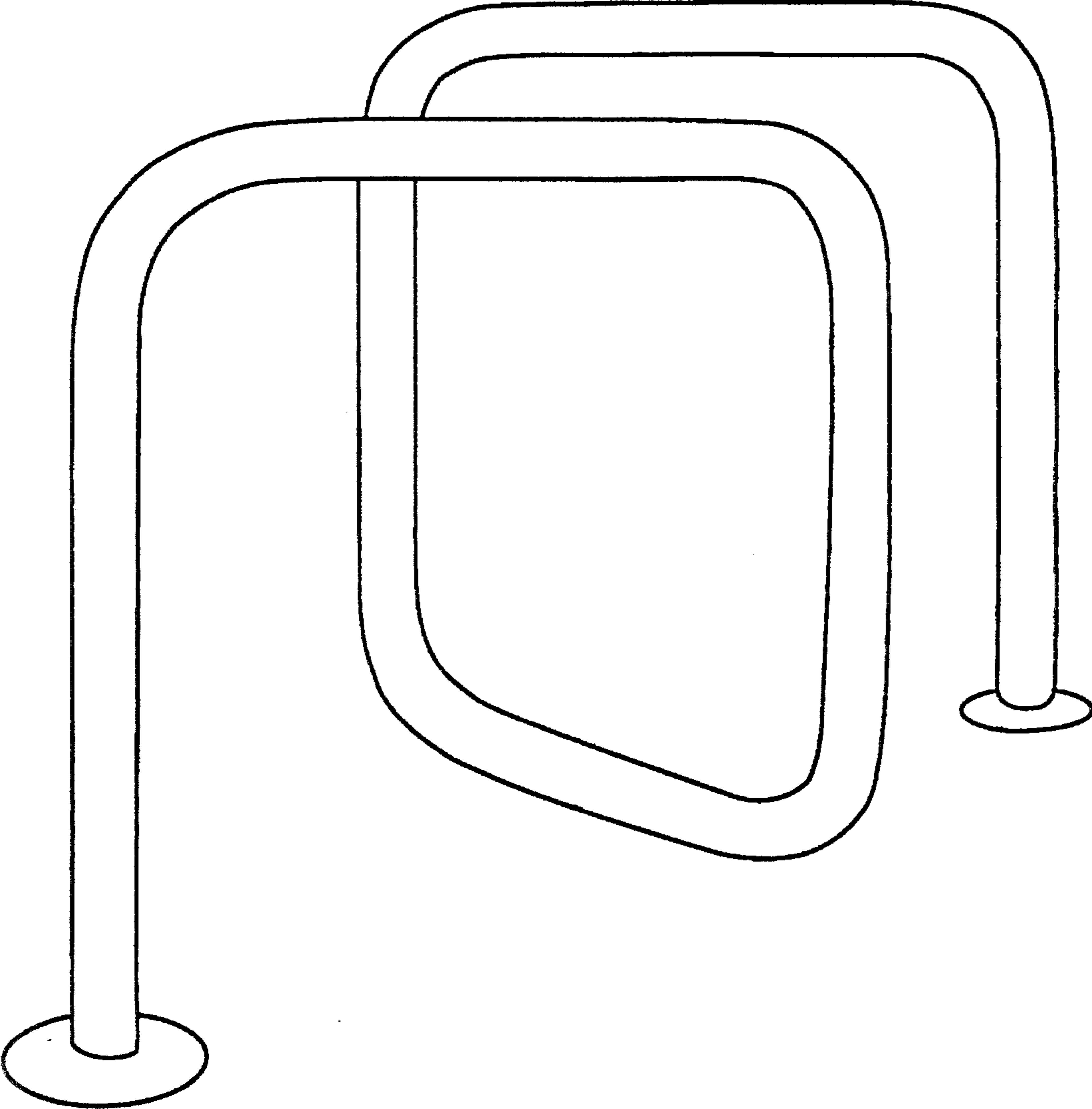

Fig.5

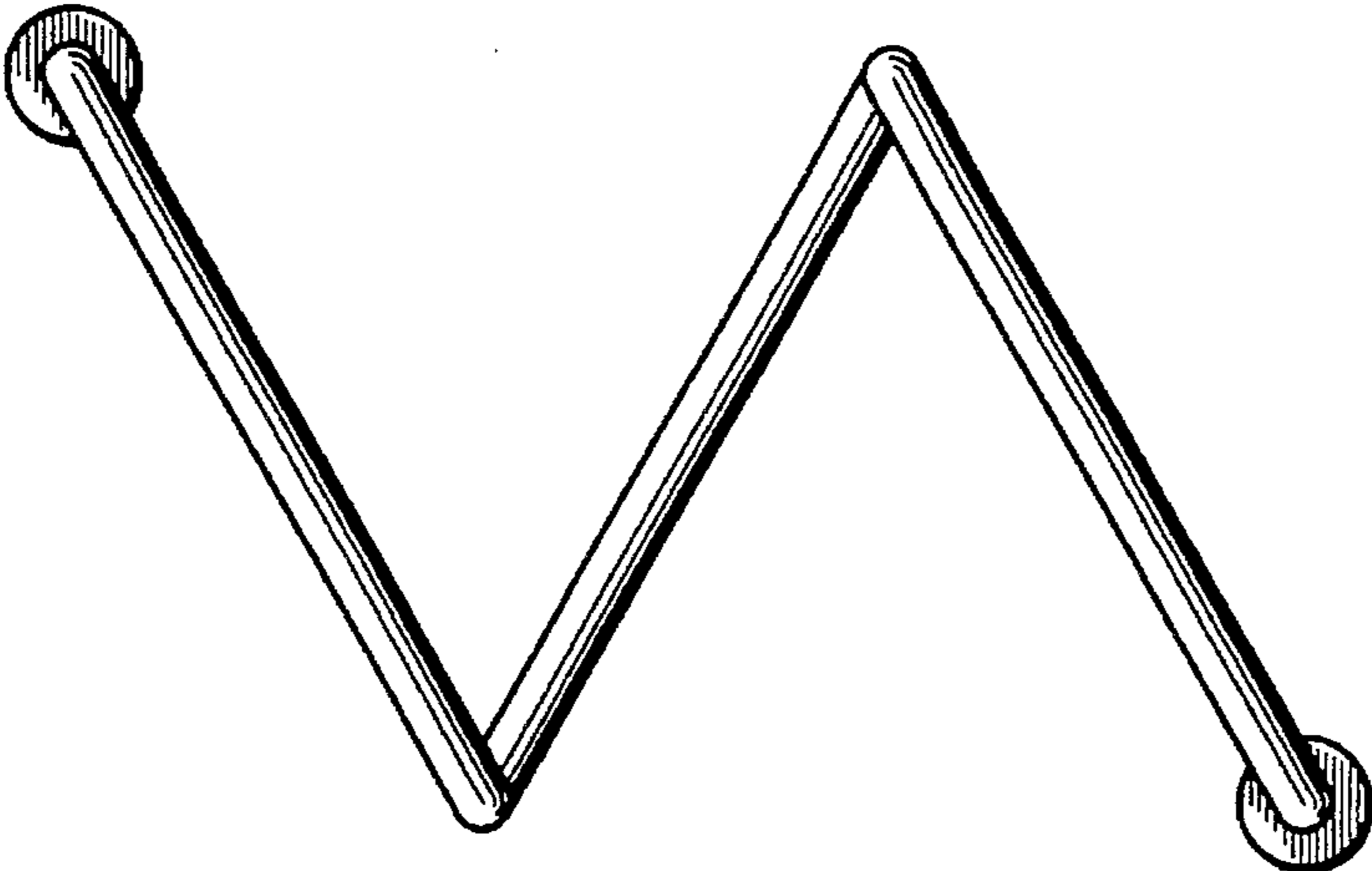

Fig.6

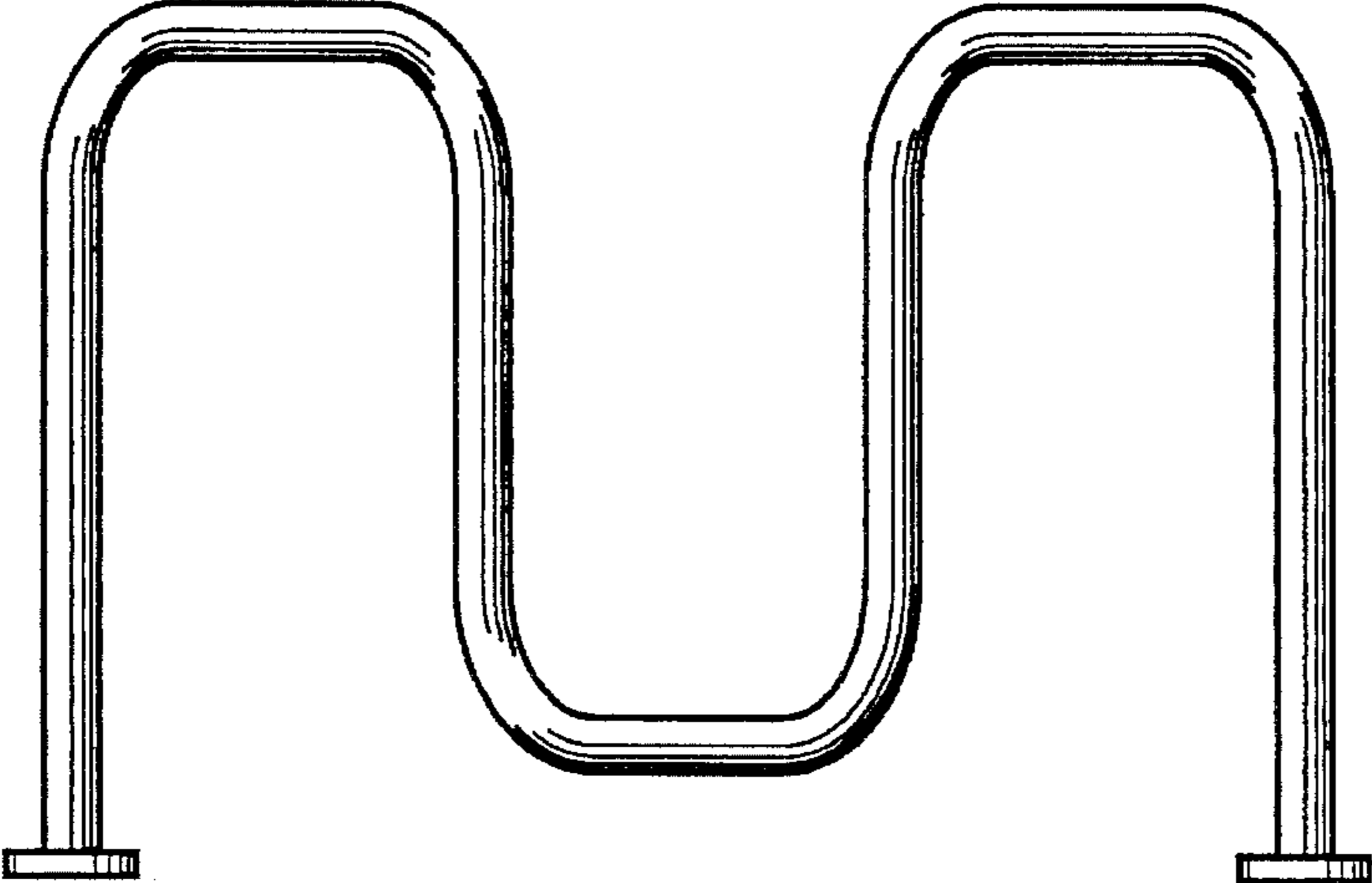

Fig.7

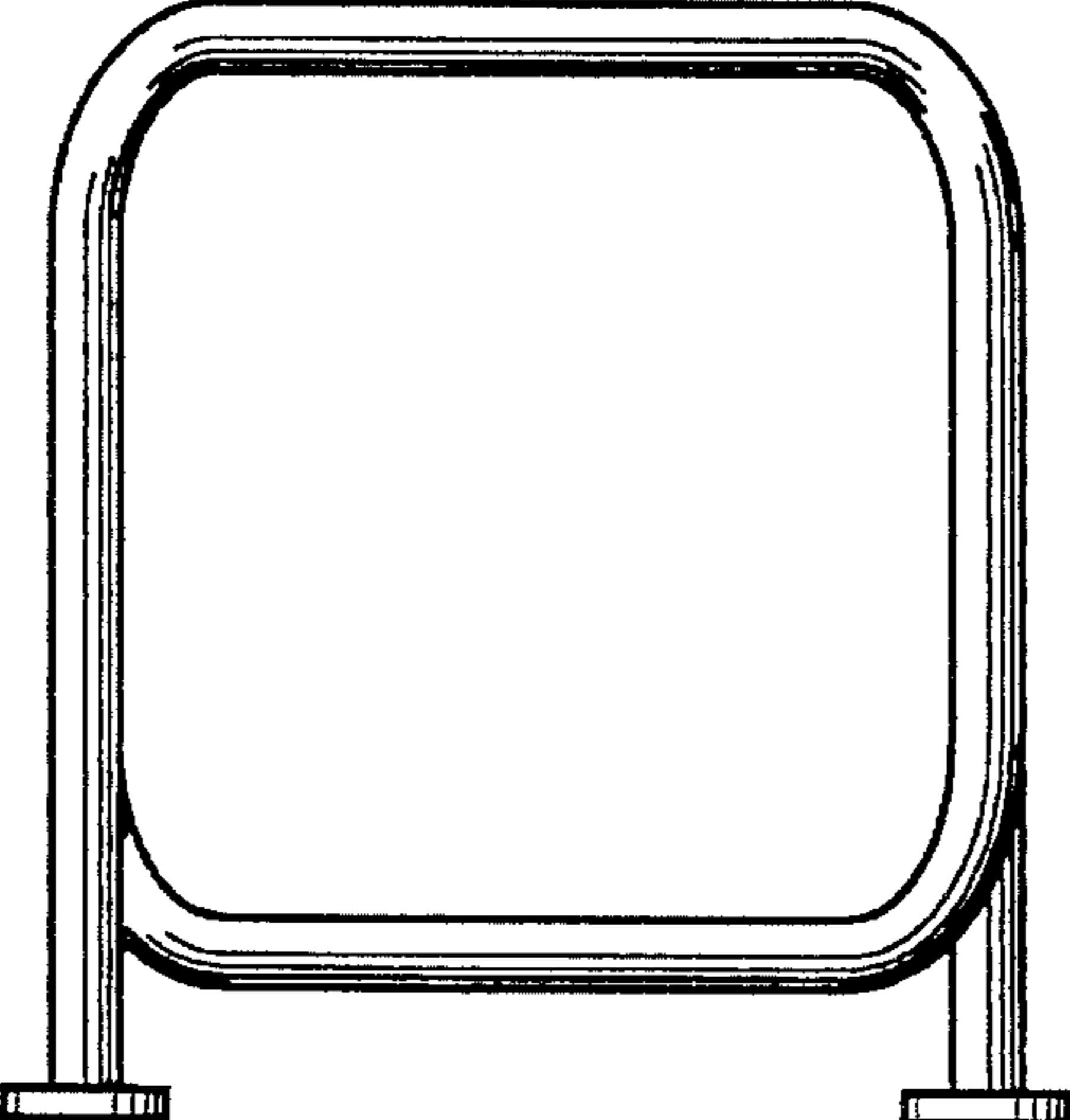

Fig.8

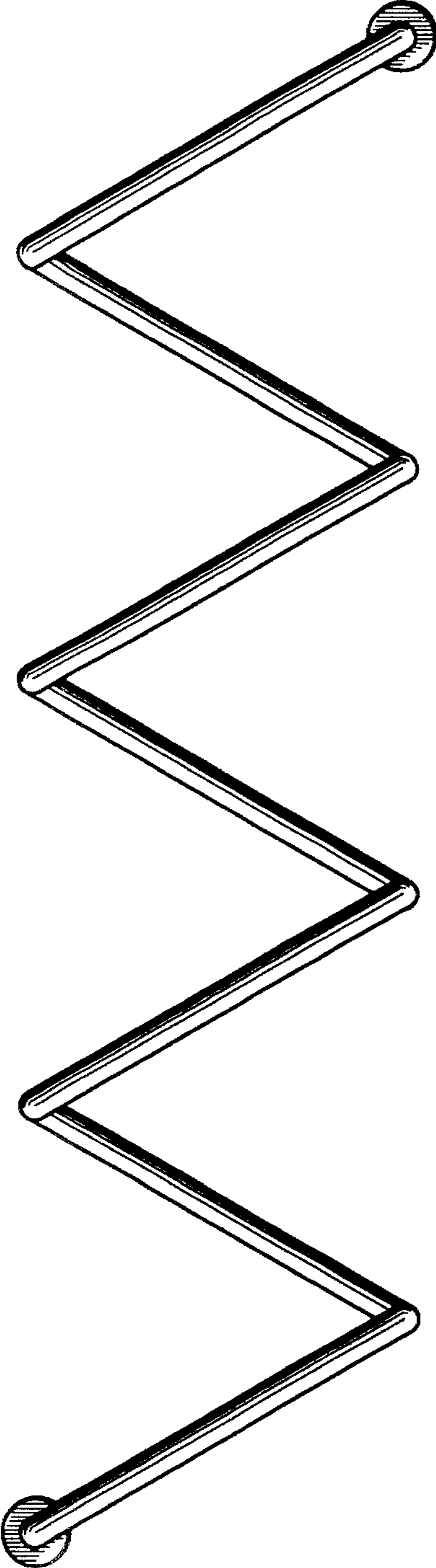

Fig. 9

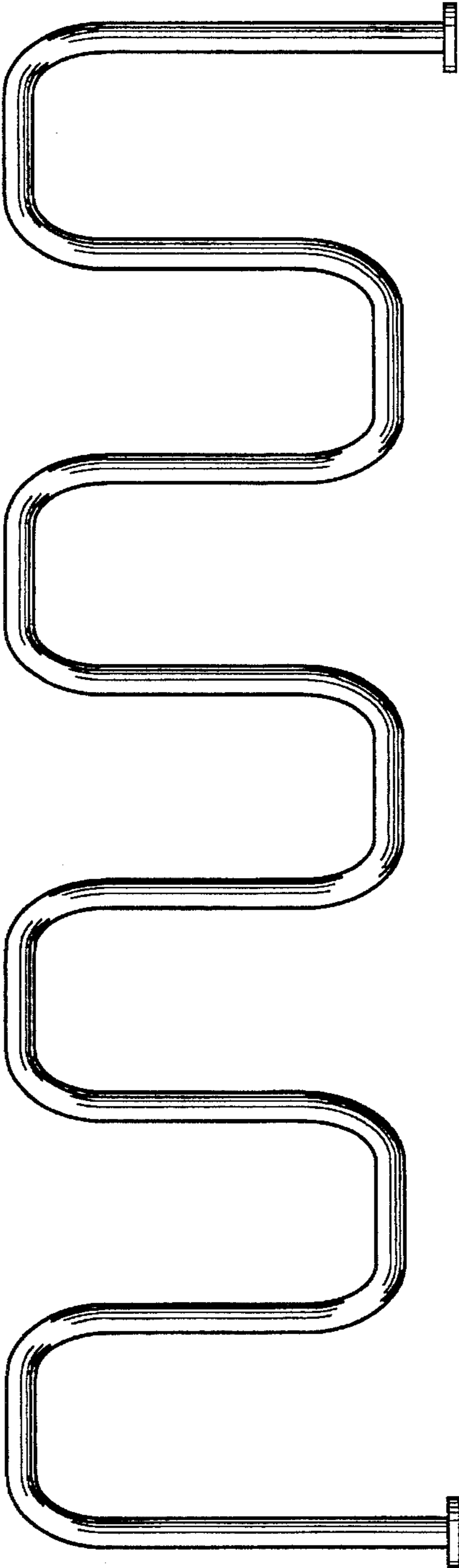

Fig. 10

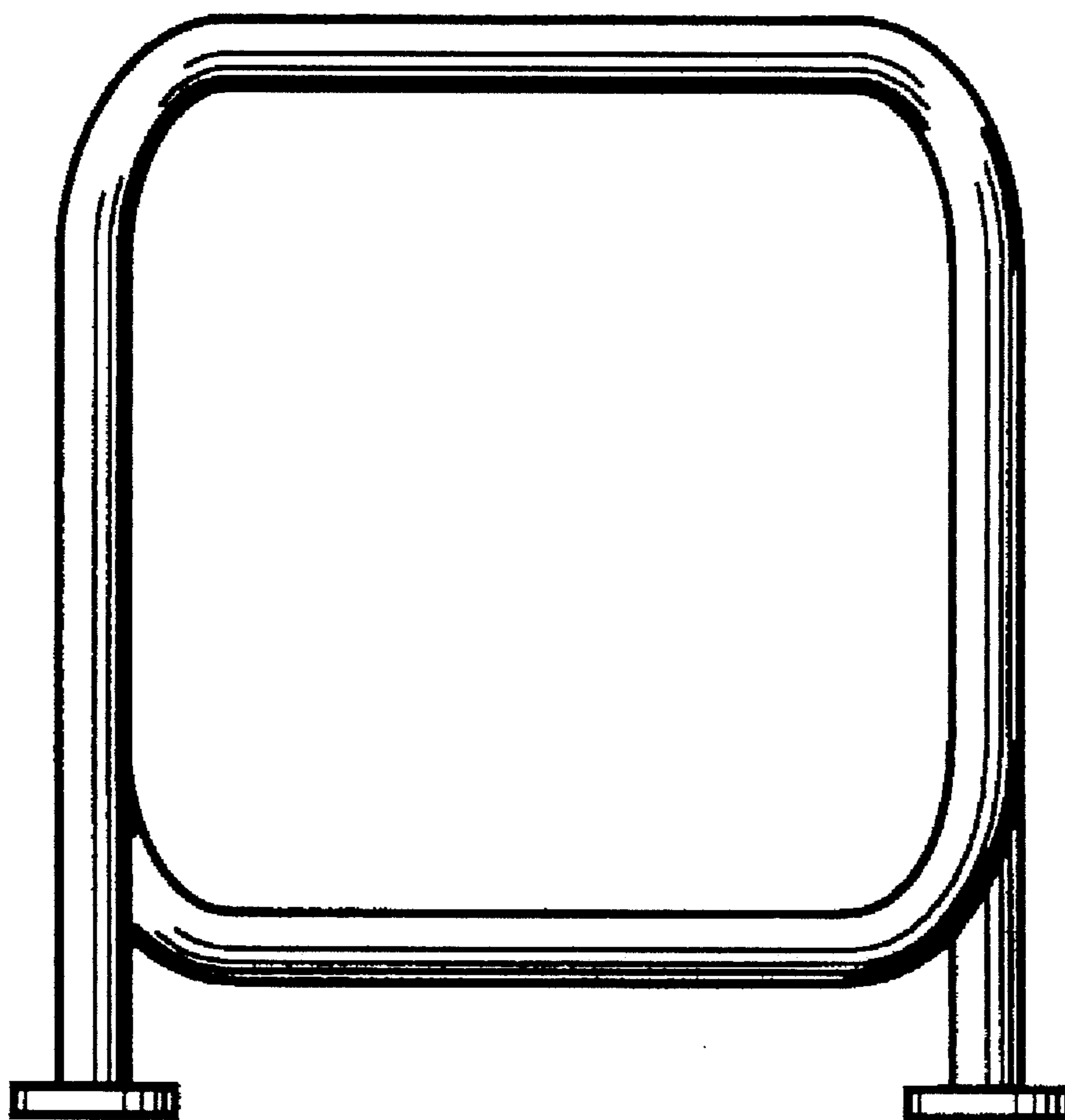

Fig. 11

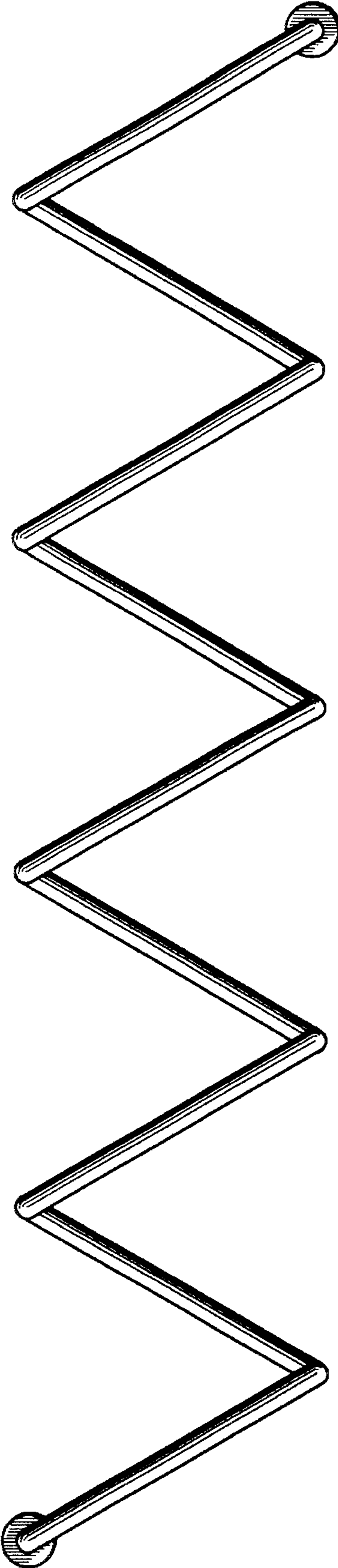

Fig. 12

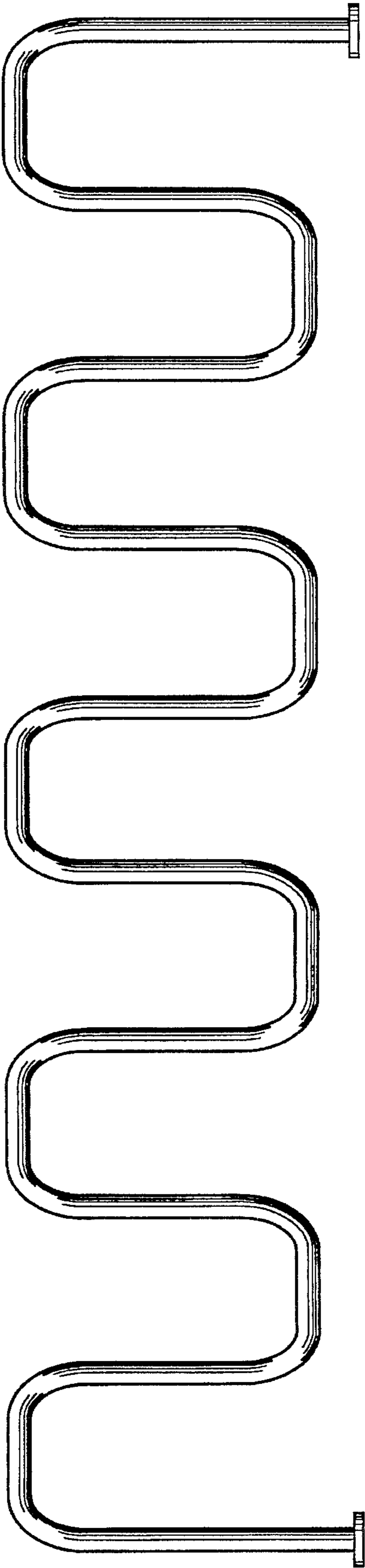

Fig. 13

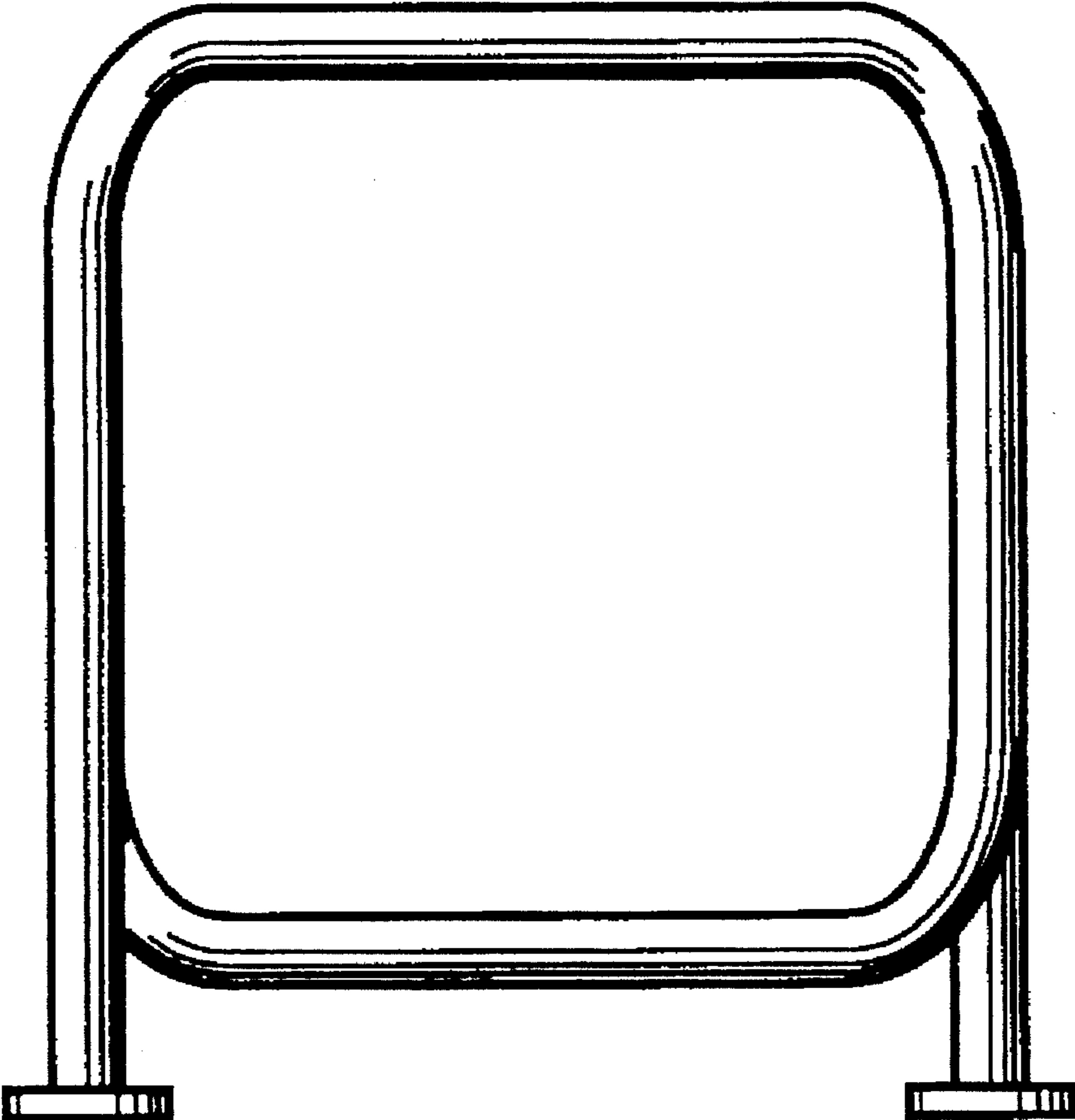

Fig. 14