



US00D366944S

**United States Patent** [19]  
**Maxwell**

[11] **Patent Number: Des. 366,944**  
[45] **Date of Patent: \*\*Feb. 6, 1996**

[54] **APPARATUS FOR DAMPENING SEISMIC VIBRATION**

[76] Inventor: **Michael J. Maxwell**, 13162 Hwy. 8, Business #28, El Cajon, Calif. 92021

[\*\*] Term: **14 Years**

[21] Appl. No.: **33,554**

[22] Filed: **Jan. 17, 1995**

[52] U.S. Cl. .... **D25/138**

[58] Field of Search ..... D25/62, 127, 134, D25/138; 52/167.4, 169.9

[56] **References Cited**

**U.S. PATENT DOCUMENTS**

4,546,581 10/1985 Gustafson ..... 52/169.9  
5,402,614 4/1995 Jewell ..... 52/169.9 X

*Primary Examiner*—Antoine Duval Davis

*Attorney, Agent, or Firm*—Frederick Gotha

[57] **CLAIM**

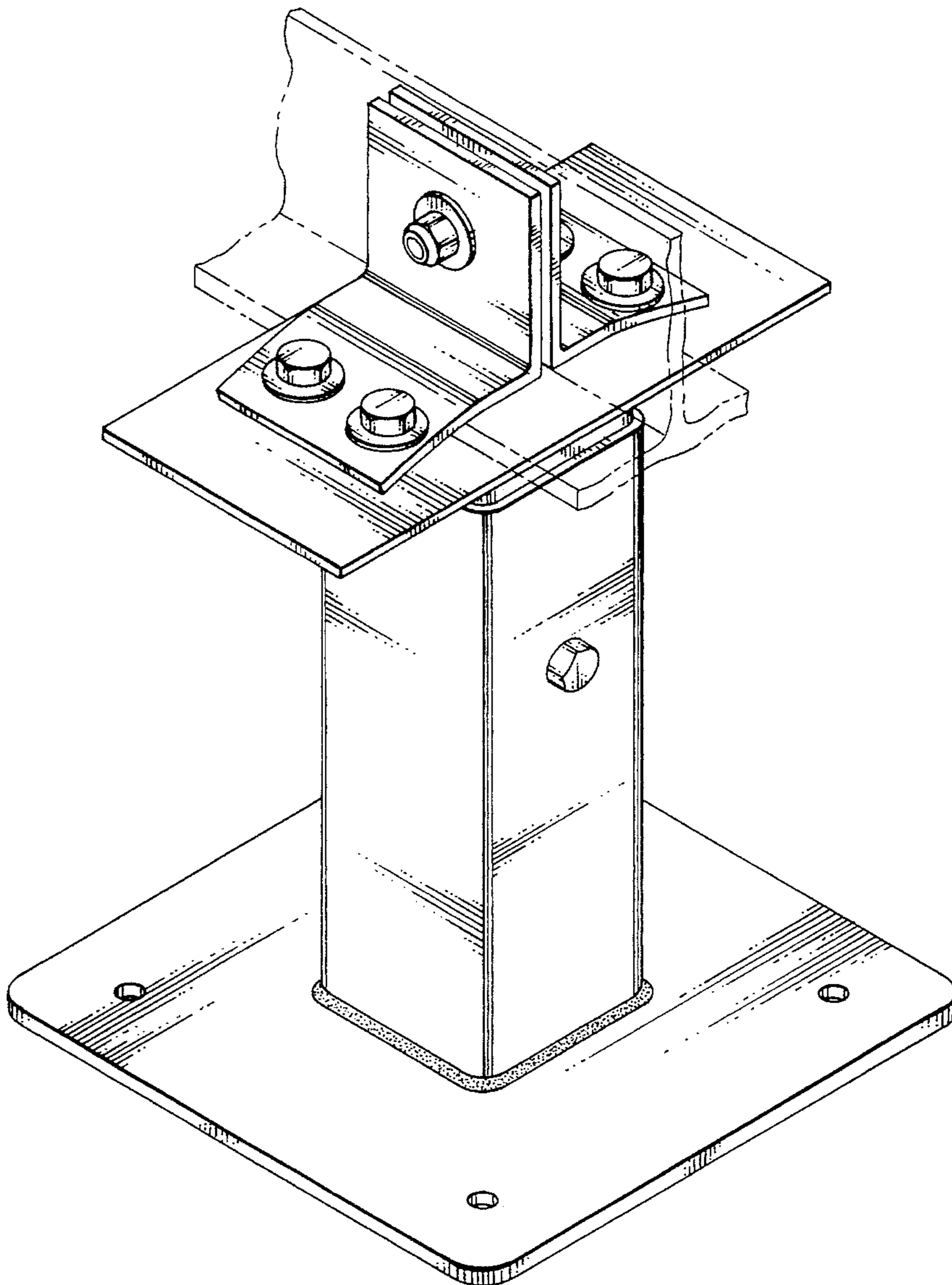
The ornamental design for an apparatus for dampening seismic vibration, as shown and described.

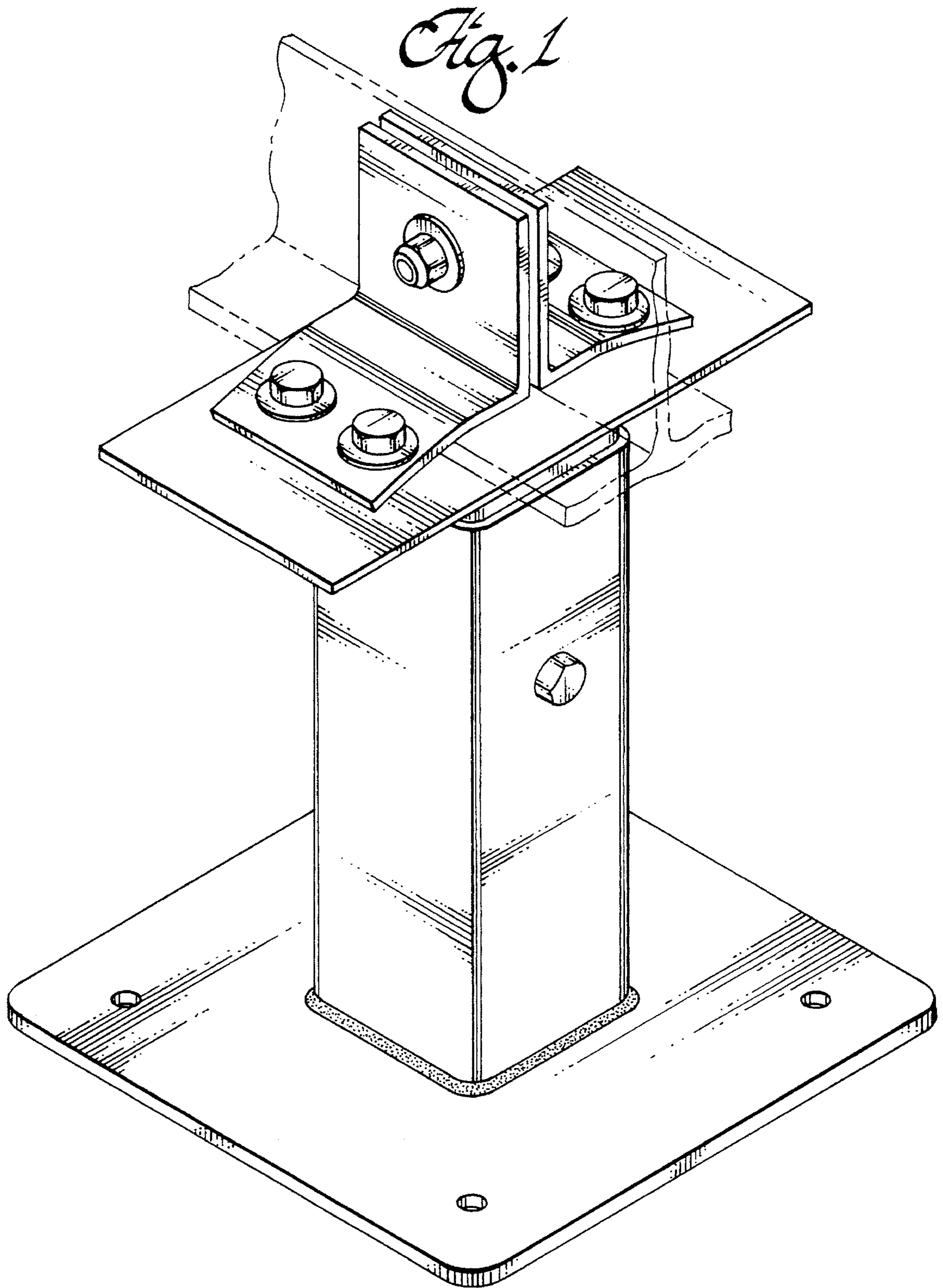
**DESCRIPTION**

FIG. 1 is a perspective view of an apparatus for dampening seismic vibration showing my new design; FIG. 2 is a front elevational view thereof; FIG. 3 is a right side elevational view thereof; FIG. 4 is a rear elevational view thereof; FIG. 5 is a left side elevational view thereof; FIG. 6 is a top plan view thereof; and, FIG. 7 is a bottom plan view thereof.

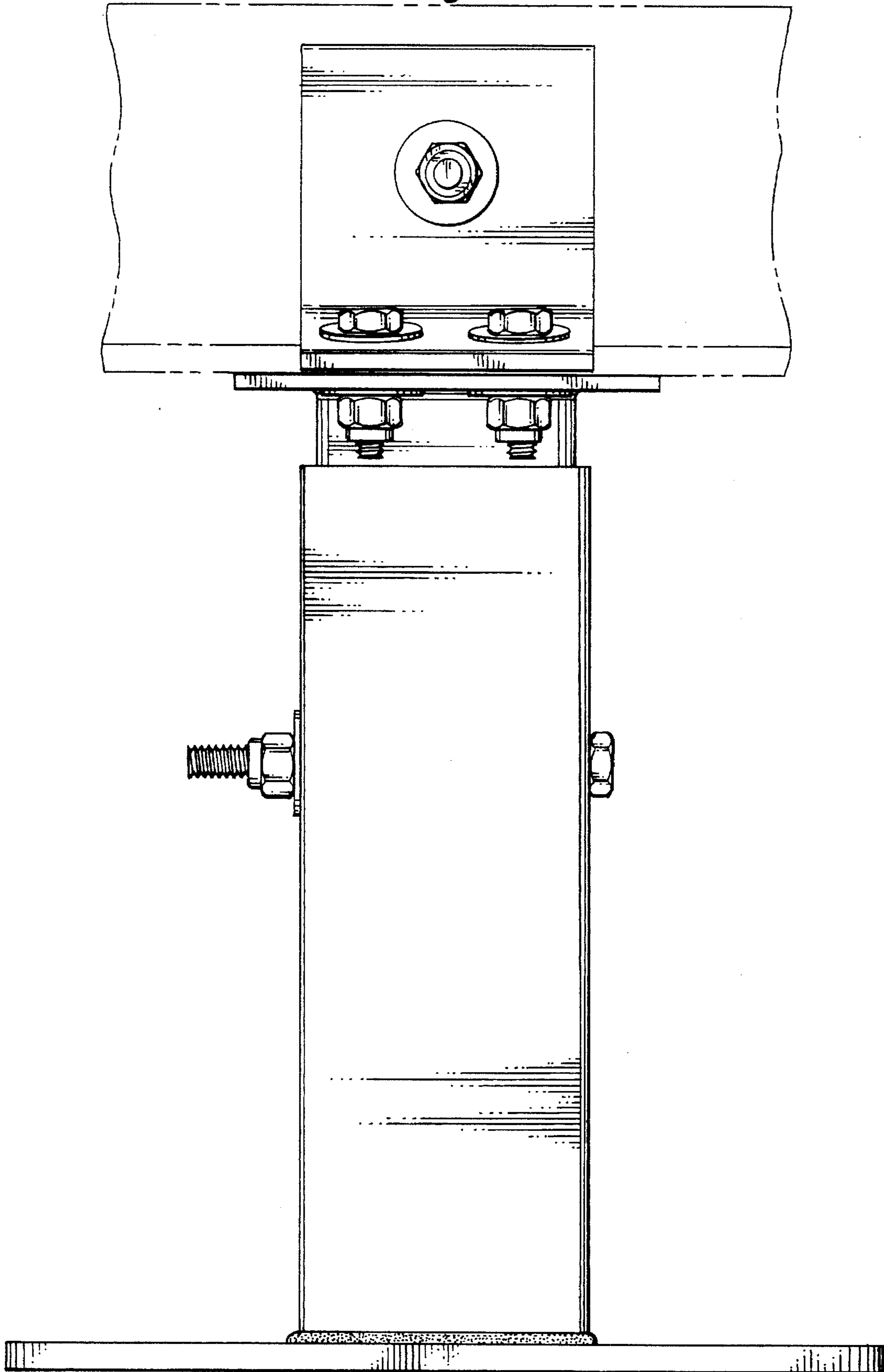
The broken line showing of an I beam is for illustrative purposes only and forms no part of the claimed design.

**1 Claim, 7 Drawing Sheets**

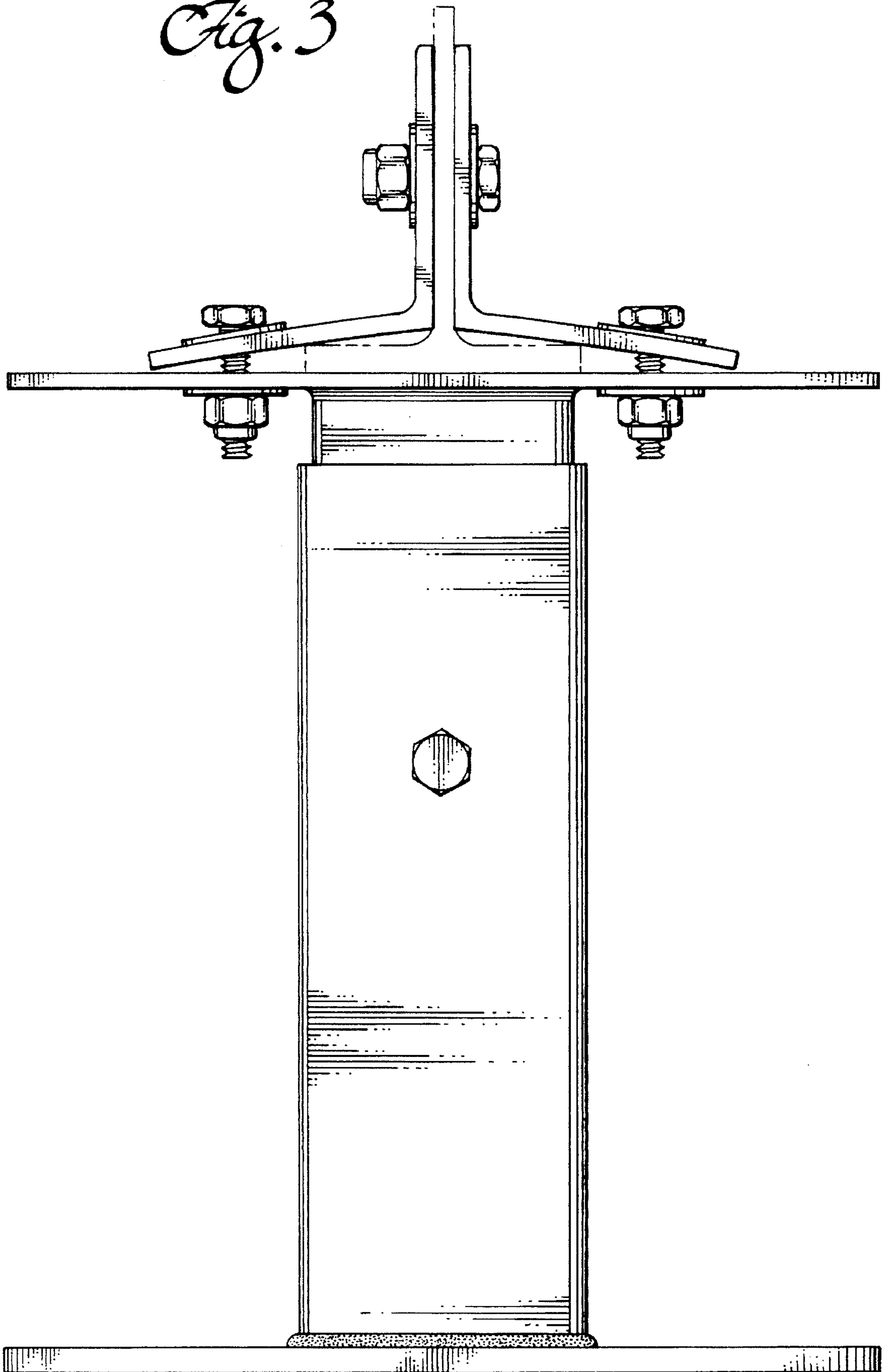




*Fig. 2*

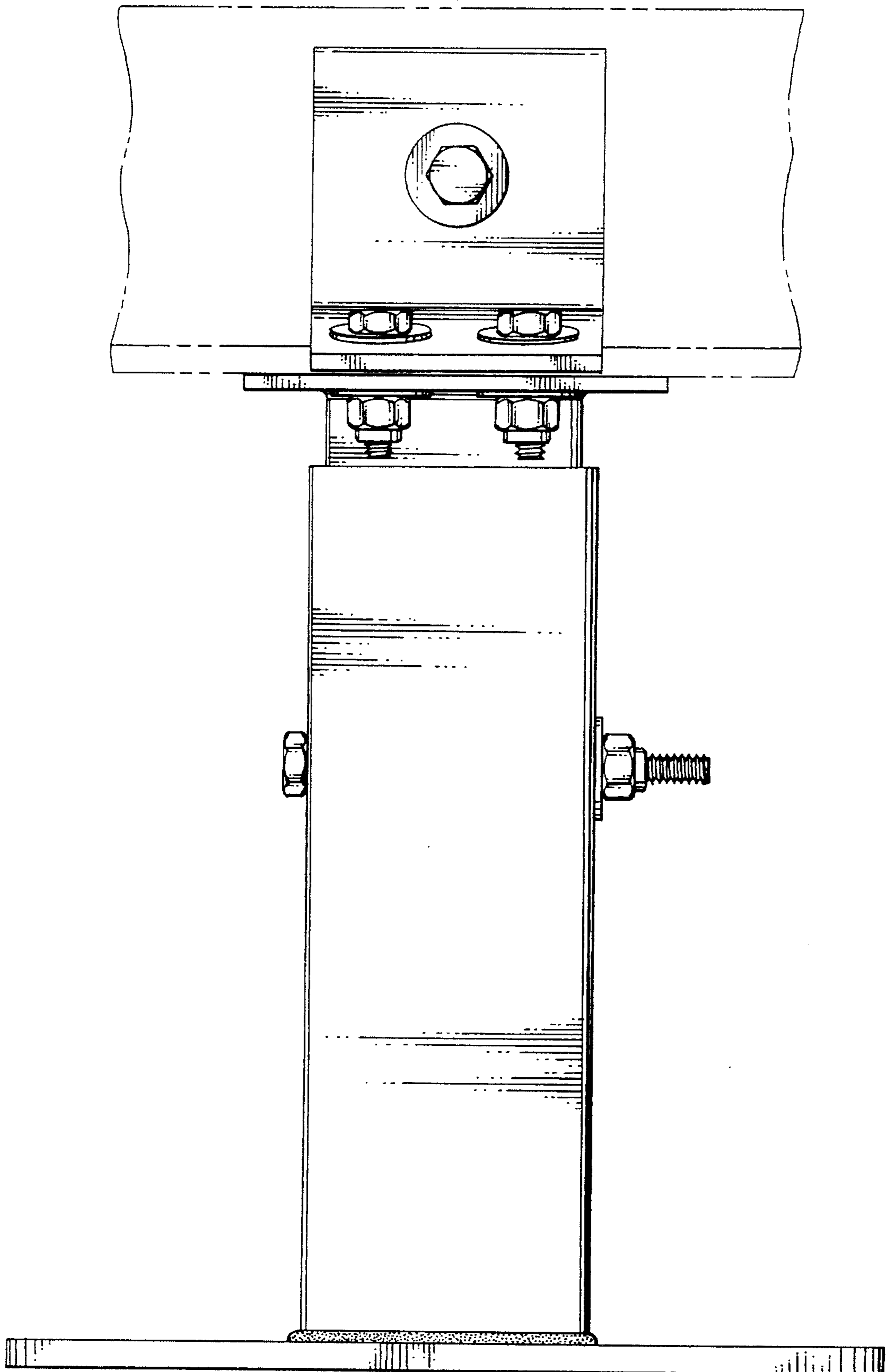


*Fig. 3*

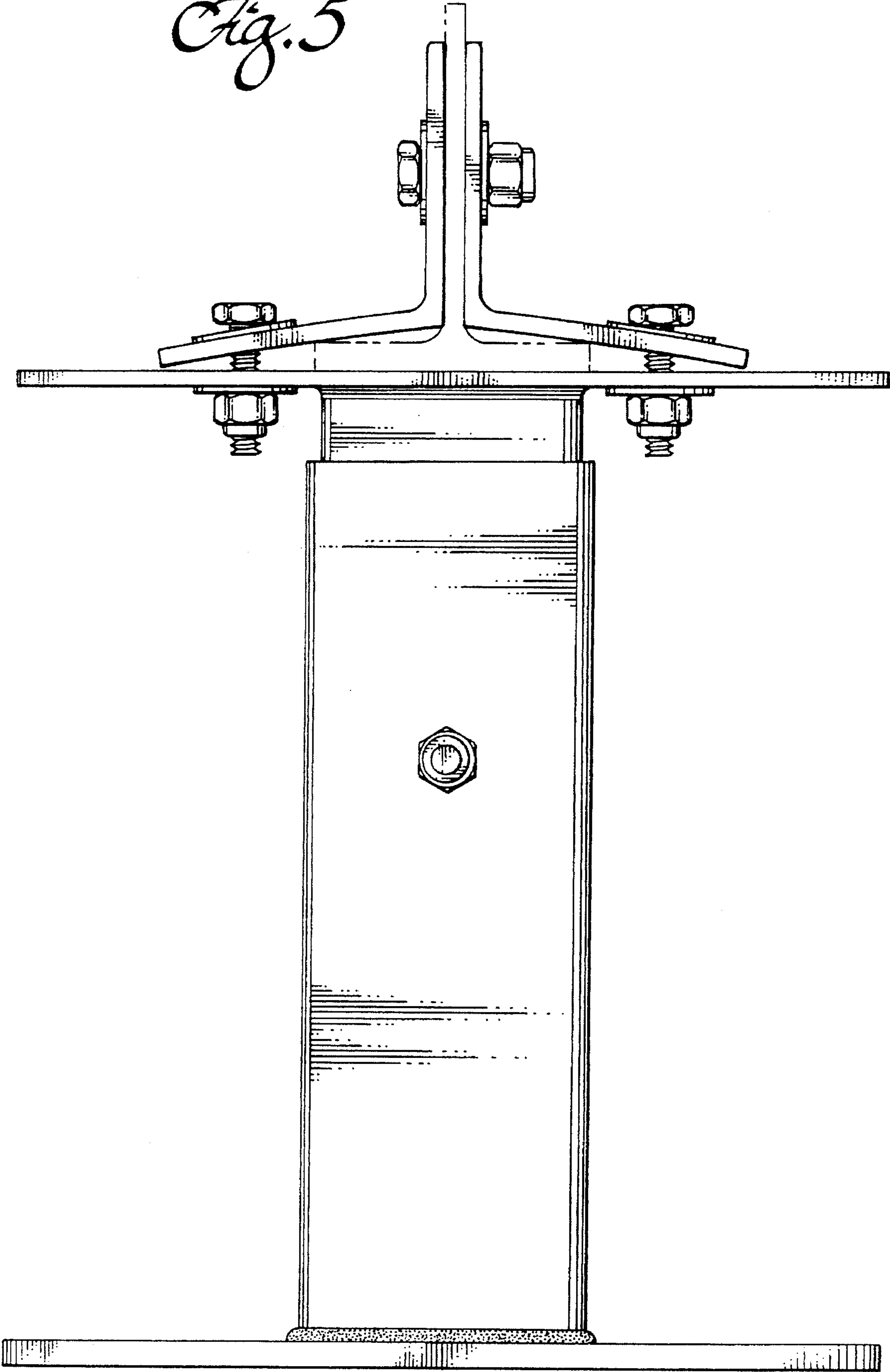




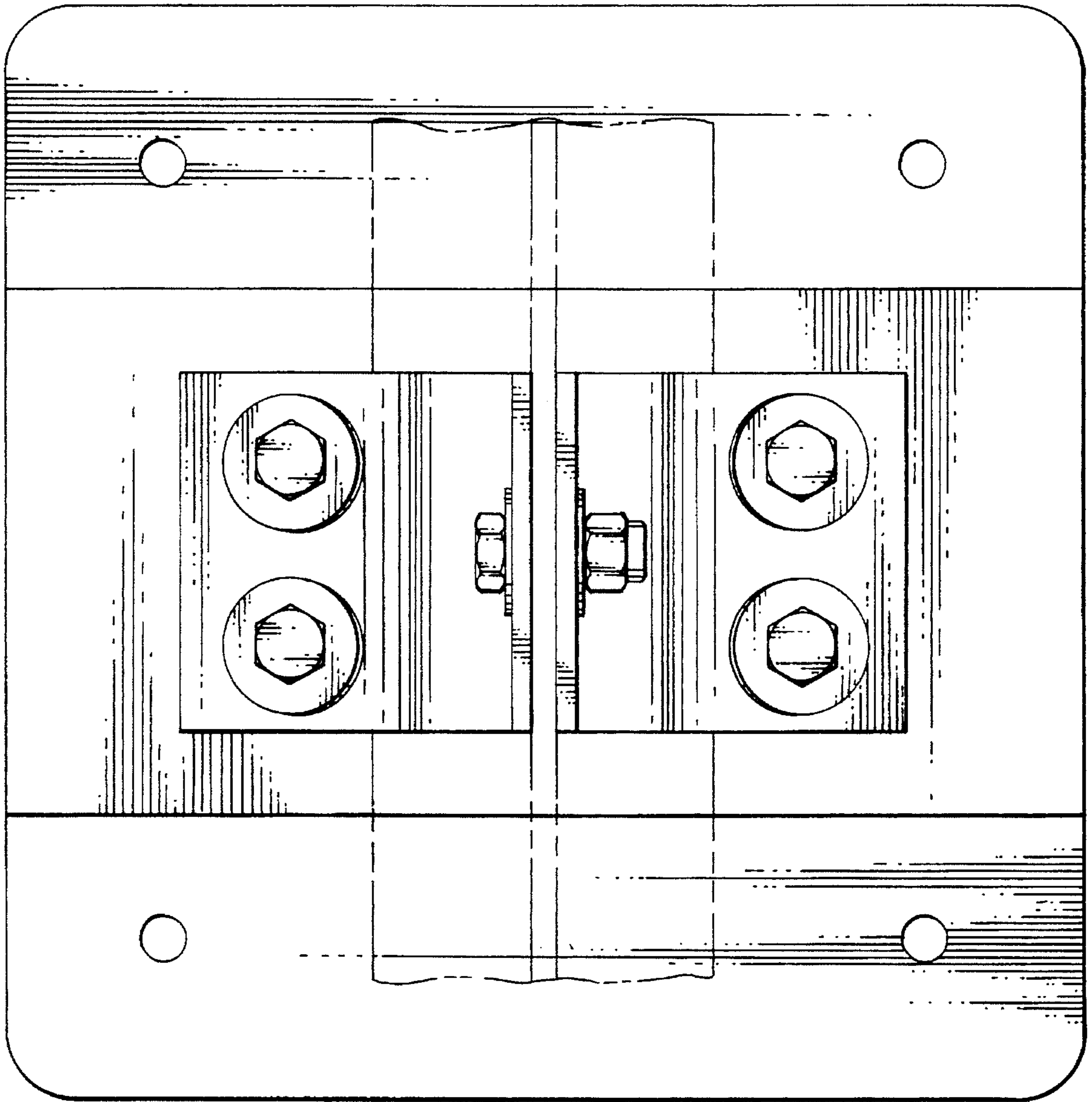
*Fig. A*



*Fig. 5*



*Fig. 6*



*Fig. 7*

