



US00D366857S

United States Patent [19]

Allen

[11] Patent Number: **Des. 366,857**

[45] Date of Patent: ****Feb. 6, 1996**

[54] **PORTABLE STORAGE CARRIER FOR VEHICLES**

D. 313,963 1/1991 Gunnarsson et al. D12/419
D. 318,950 8/1991 Chatman D12/419

[76] Inventor: **Melvin Allen**, 3741 Crest Dr.,
Hephzibah, Ga. 30815

Primary Examiner—A. Hugo Word
Assistant Examiner—M. Brown

[**] Term: **14 Years**

[57] **CLAIM**

[21] Appl. No.: **13,341**

The ornamental design for a portable storage carrier for vehicles, as shown and described.

[22] Filed: **Sep. 22, 1993**

DESCRIPTION

[52] U.S. Cl. **D12/425**

[58] **Field of Search** D12/425, 420,
D12/424, 419; 224/42.42, 42.45, 42.46,
42.11, 273; 280/164.1, 760; 296/37.1, 37.6

FIG. 1 is a front elevational view of the portable storage carrier for vehicles showing my new design; FIG. 2 is a rear elevational view thereof; FIG. 3 is a left side elevational view thereof; FIG. 4 is a right side elevational view thereof; FIG. 5 is a top plan view thereof; FIG. 6 is a bottom plan view thereof; and, FIG. 7 is a perspective view thereof.

[56] **References Cited**

U.S. PATENT DOCUMENTS

- D. 141,908 7/1945 Prior D12/425
- D. 165,667 1/1952 Sheets D12/420
- D. 206,449 12/1966 Terry D12/420
- D. 238,975 2/1976 Miller D12/424
- D. 255,790 7/1980 McManigal D12/424

The broken lines shown in FIG. 5 are for illustrative purposes only and form no part of the claimed design.

1 Claim, 4 Drawing Sheets

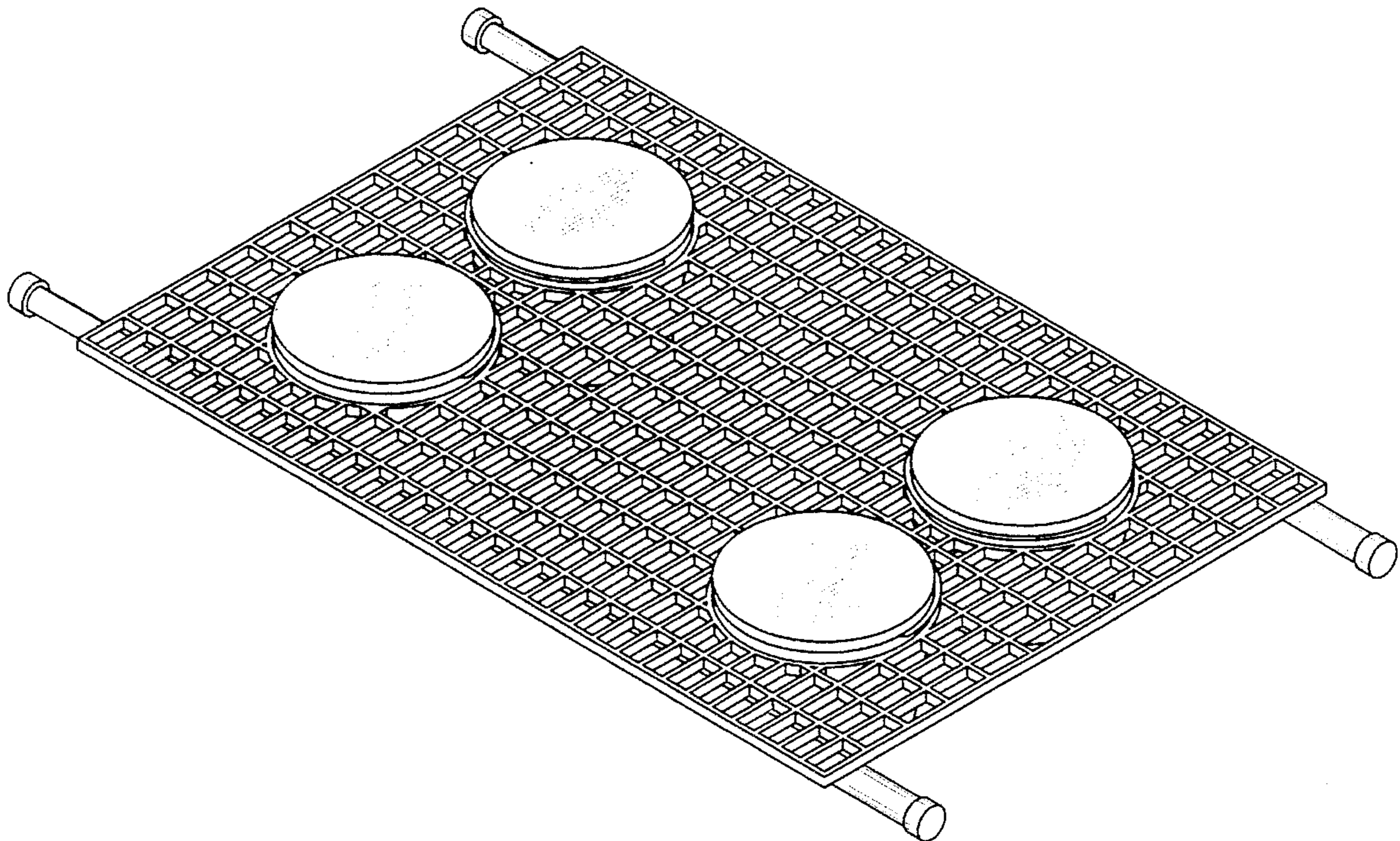
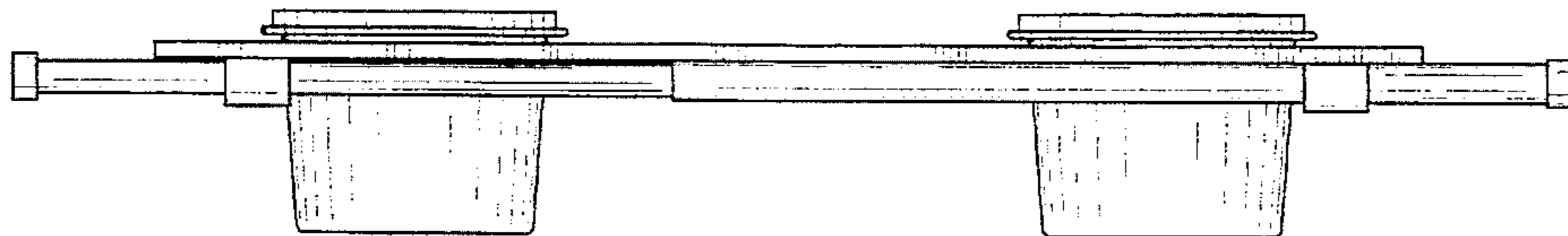

FIG. 1

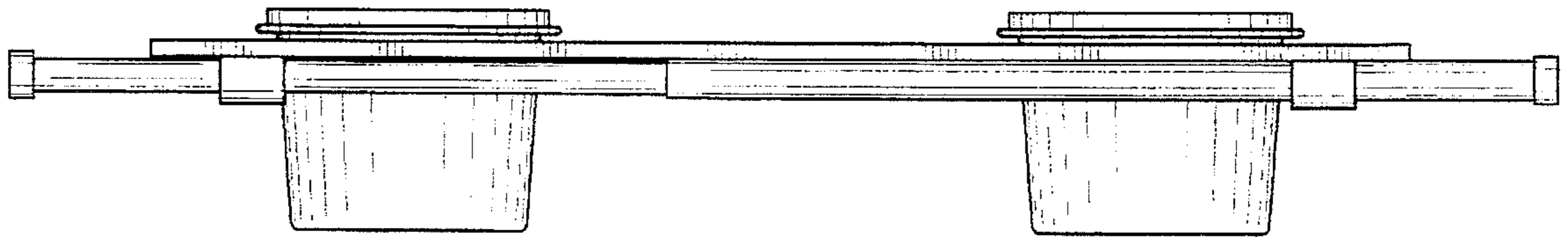

FIG. 2

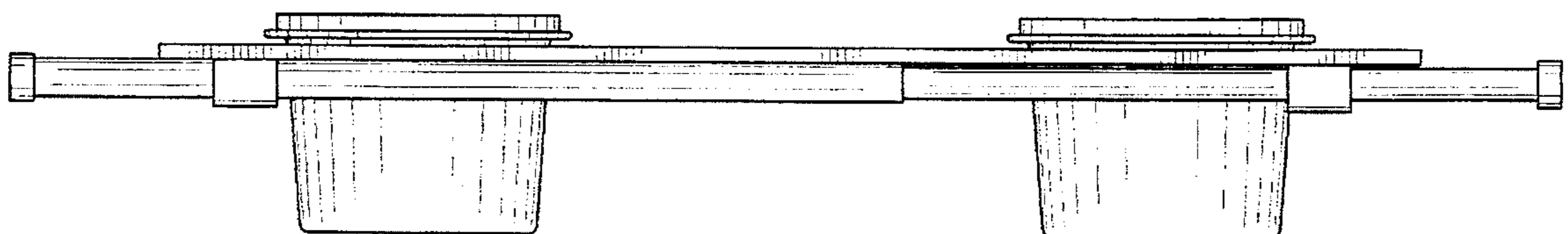

FIG. 3

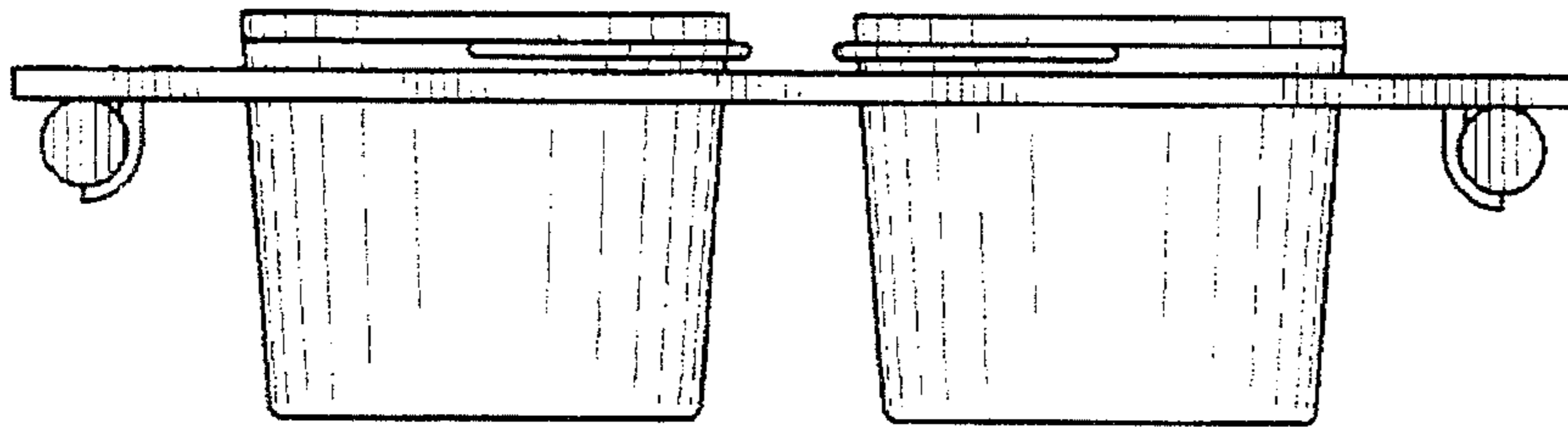

FIG. 4

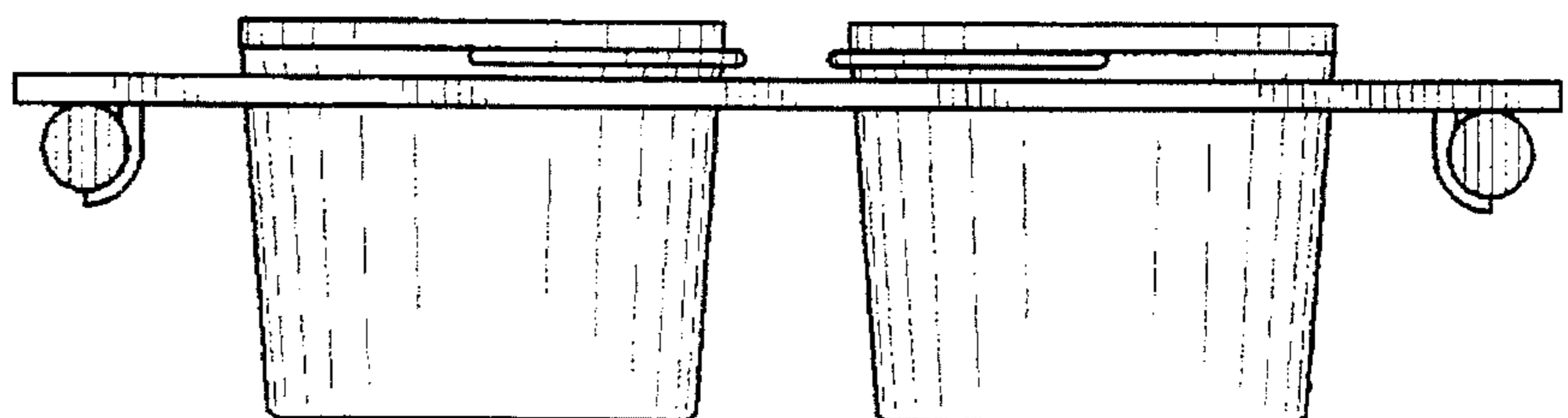

FIG. 5

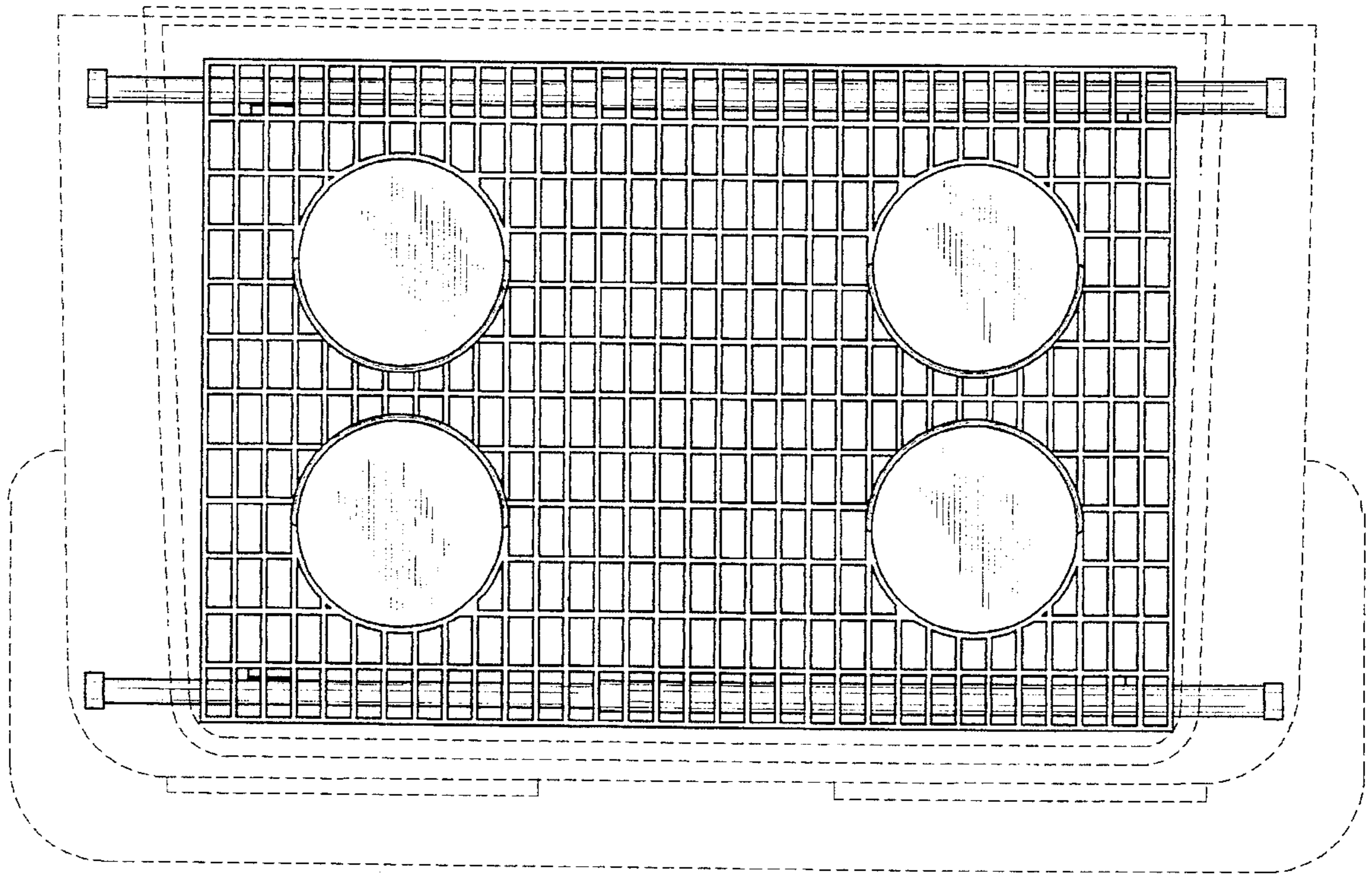

FIG. 6

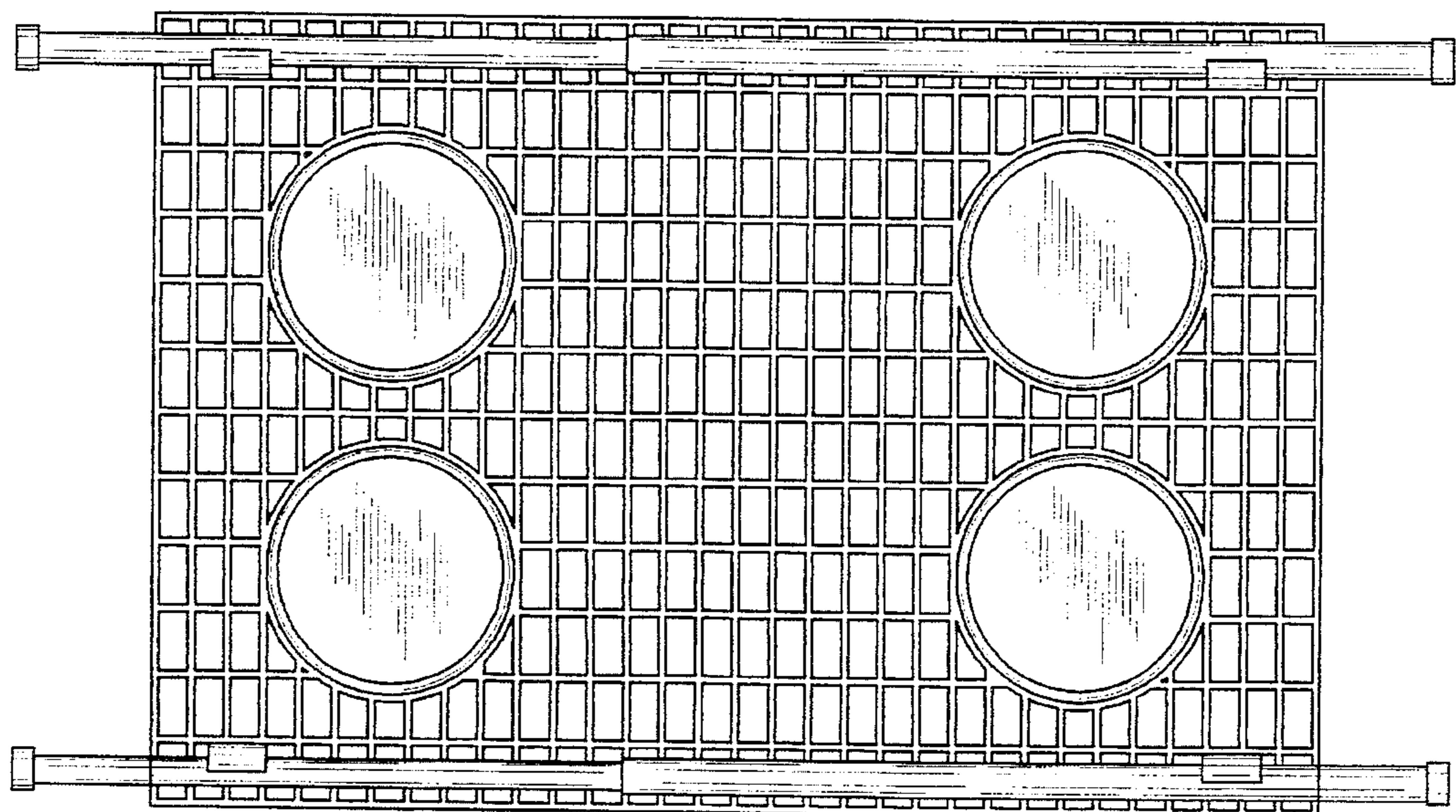

FIG. 7

