



US00D366662S

United States Patent [19]

[11] Patent Number: **Des. 366,662**

Haffely et al.

[45] Date of Patent: ****Jan. 30, 1996**

[54] GRINDING AND SHARPENING MACHINE

[75] Inventors: **Jeffrey L. Haffely**, Gibsonia; **Xun Lei**, Cheswick; **Louis C. Brickner**, Pittsburgh, all of Pa.

[73] Assignee: **Delta International Machinery Corp.**, Pittsburgh, Pa.

[**] Term: **14 Years**

[21] Appl. No.: **26,701**

[22] Filed: **Aug. 9, 1994**

[52] U.S. Cl. **D15/124**

[58] Field of Search D15/124, 125, D15/130, 133, 134, 199; 76/37, 40, 41, 51, 77; 144/1 R, 38, 136 R; 409/162; 451/340, 367, 65, 224, 241

[56] References Cited

U.S. PATENT DOCUMENTS

D. 299,467	1/1989	Ritt	D15/131
D. 338,901	8/1993	Chen	D15/124
3,885,352	5/1975	Juranitch	451/65
4,436,000	3/1984	Lenard et al.	76/41
4,996,797	3/1991	Laughton	D15/124 X

OTHER PUBLICATIONS

Instruction Manual for Makita Sharpener Model 9820-2 of Makita Electric Works, Ltd., Dated 1985.

Instruction Manual for Delta Model No. 23-700 Wet/Dry Grinder, Delta International Machinery Corp., Pittsburgh, PA, Dated Mar. 15, 1988.

AMT Power Tool Catalog, Depicting AMT Model No. 4881

Horizontal Wet Wheel, American Machine and Tool Company, Royersford, PA, Dated Fall 1994.

Delta Building Trades and Home Shop Machinery Catalog, depicting on pp. 73-74 the Delta Model No. 23-680 6" Bench Grinder, Model No. 23-980 10" Bench Grinder, Model No. 23-880 8" Bench Grinder, Model No. 23-580 5" Bench Grinder, and Model No. 23-660 6" Bench Grinder, Delta International Machinery Corp., Pittsburgh, PA, Dated Jan. 1994.

Primary Examiner—Antoine Duval Davis

Attorney, Agent, or Firm—Kirkpatrick & Lockhart

[57] CLAIM

The ornamental design for a grinding and sharpening machine, as shown.

DESCRIPTION

FIG. 1 is a front elevational view of the grinding and sharpening machine of the present invention;

FIG. 2 is a rear elevational view of the grinding and sharpening machine illustrated in FIG. 1;

FIG. 3 is a top view of the grinding and sharpening machine illustrated in FIG. 1;

FIG. 4 is a bottom view of the grinding and sharpening machine illustrated in FIG. 1;

FIG. 5 is a left side elevational view of the grinding and sharpening machine illustrated in FIG. 1; and,

FIG. 6 is a right side elevational view of the grinding and sharpening machine illustrated in FIG. 1; and,

FIG. 7 is a front perspective view from the left side and from below of the grinding and sharpening machine illustrated in FIG. 1.

1 Claim, 7 Drawing Sheets

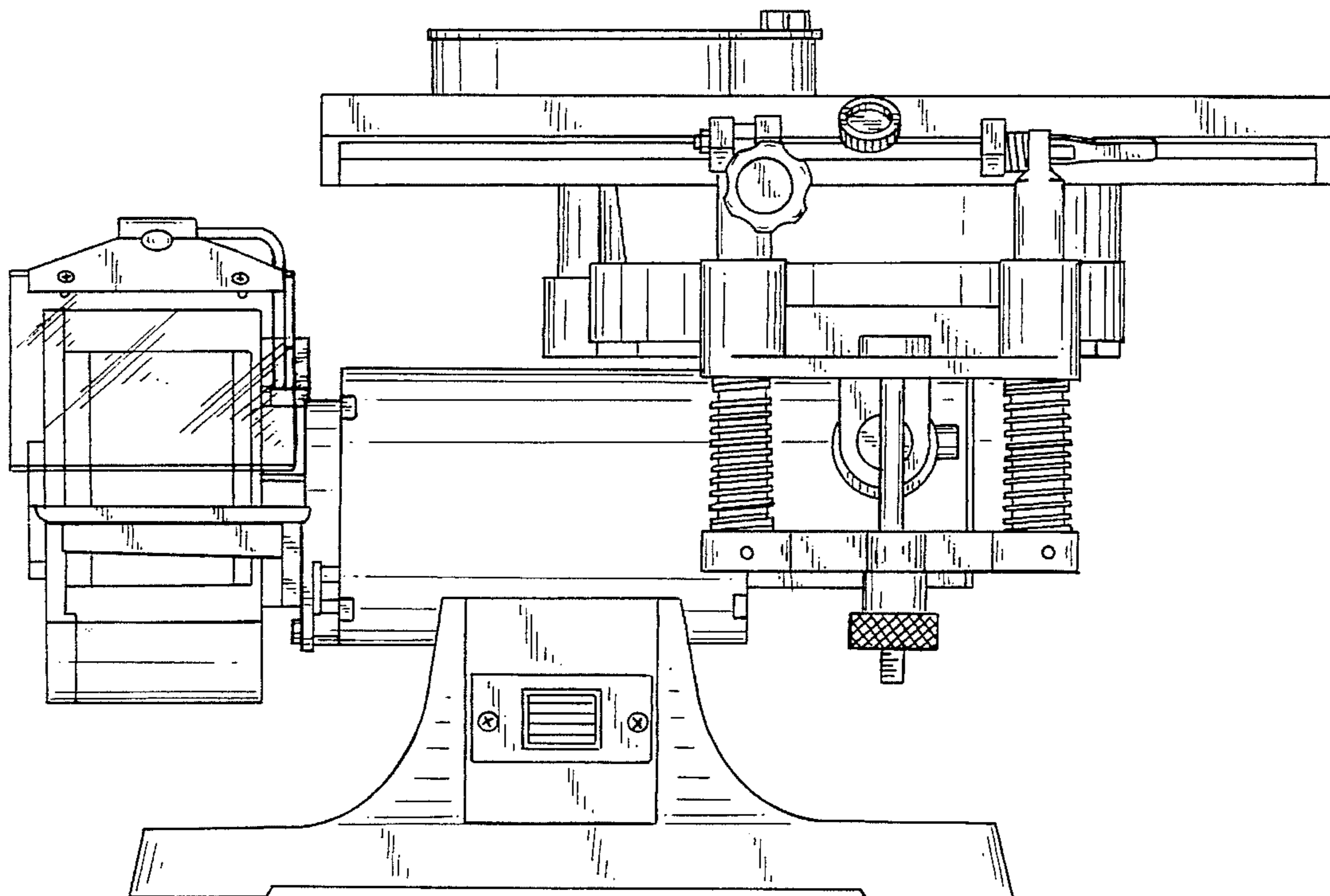

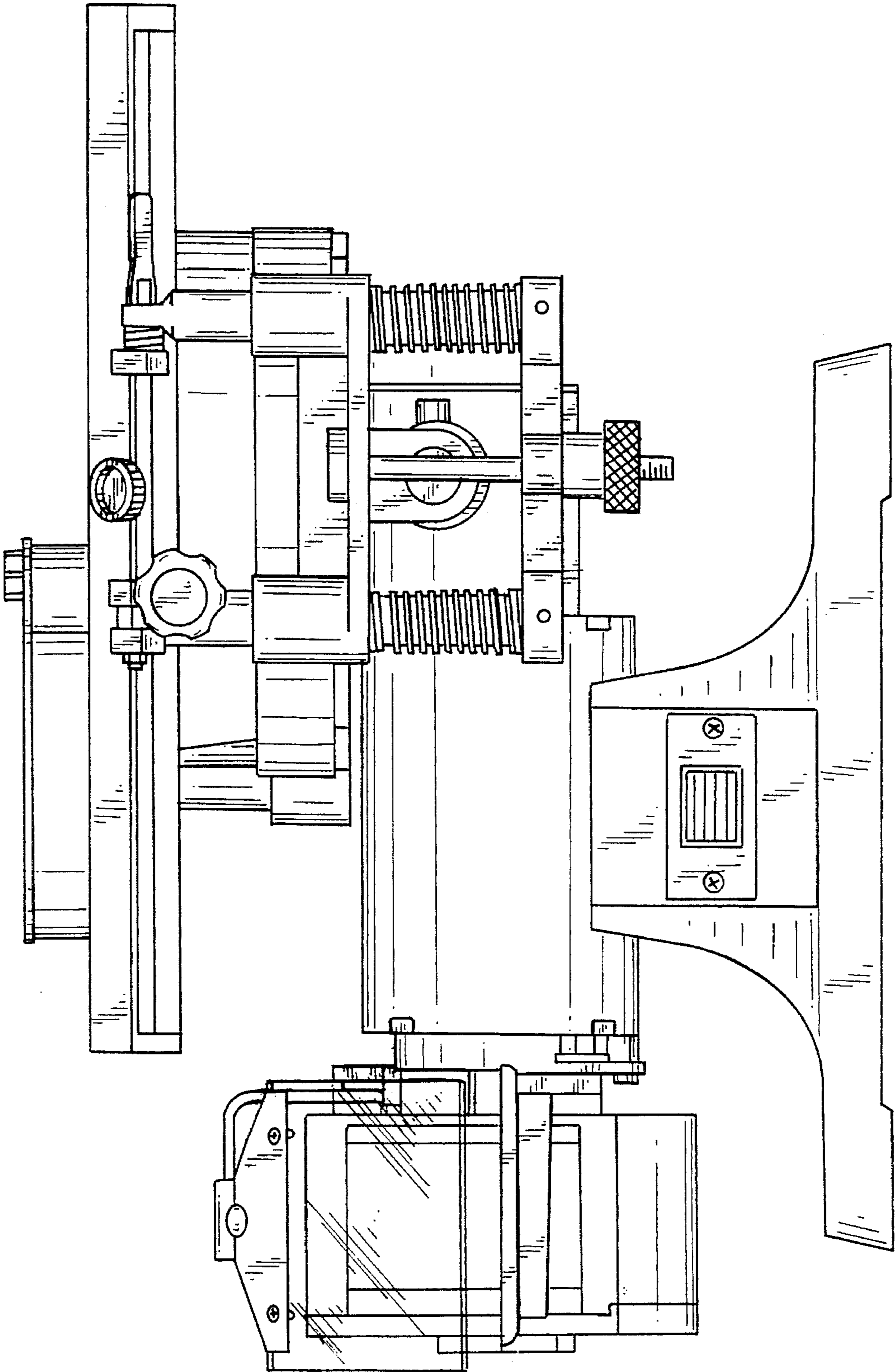

FIG. 1

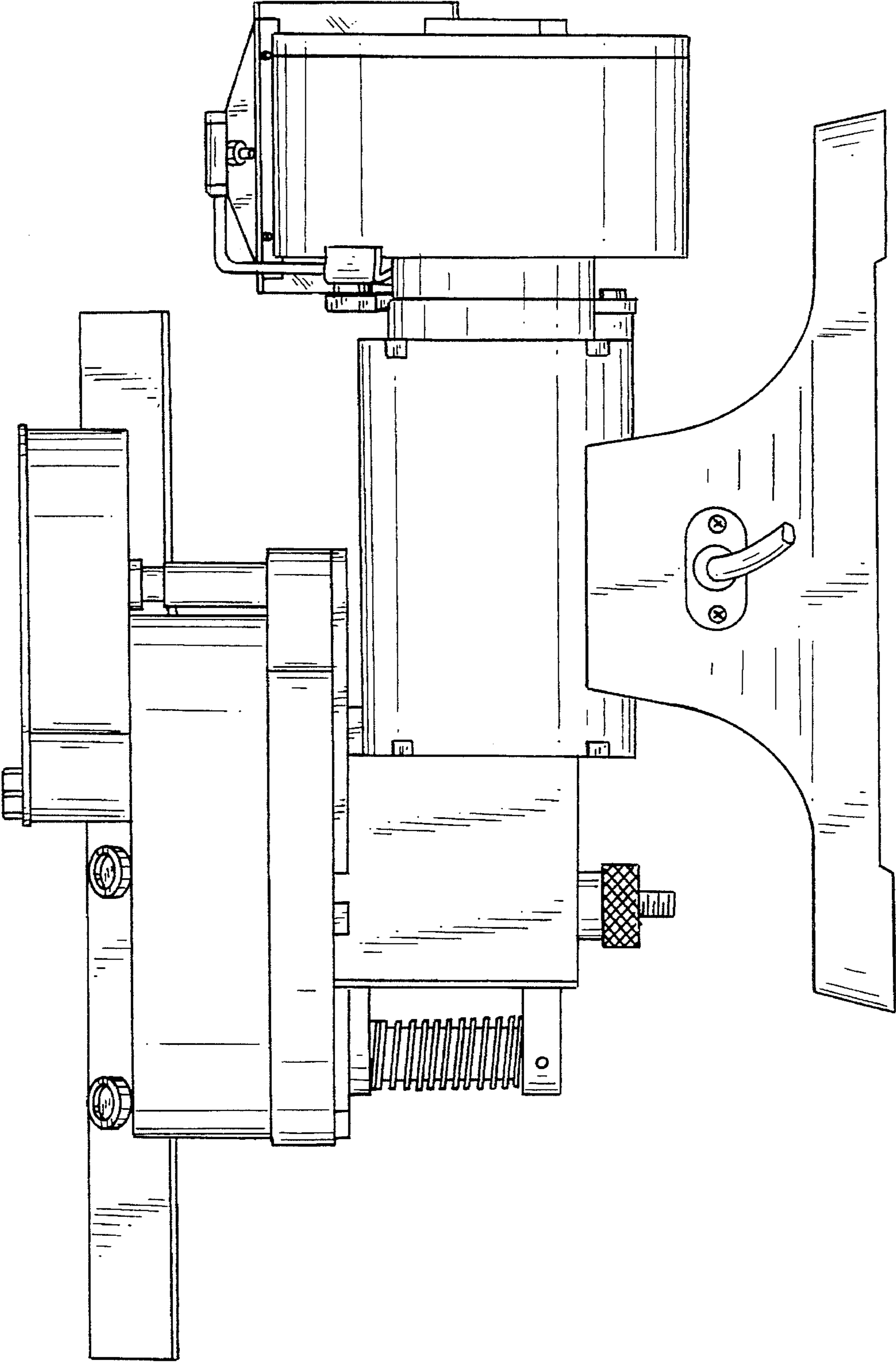

FIG. 2

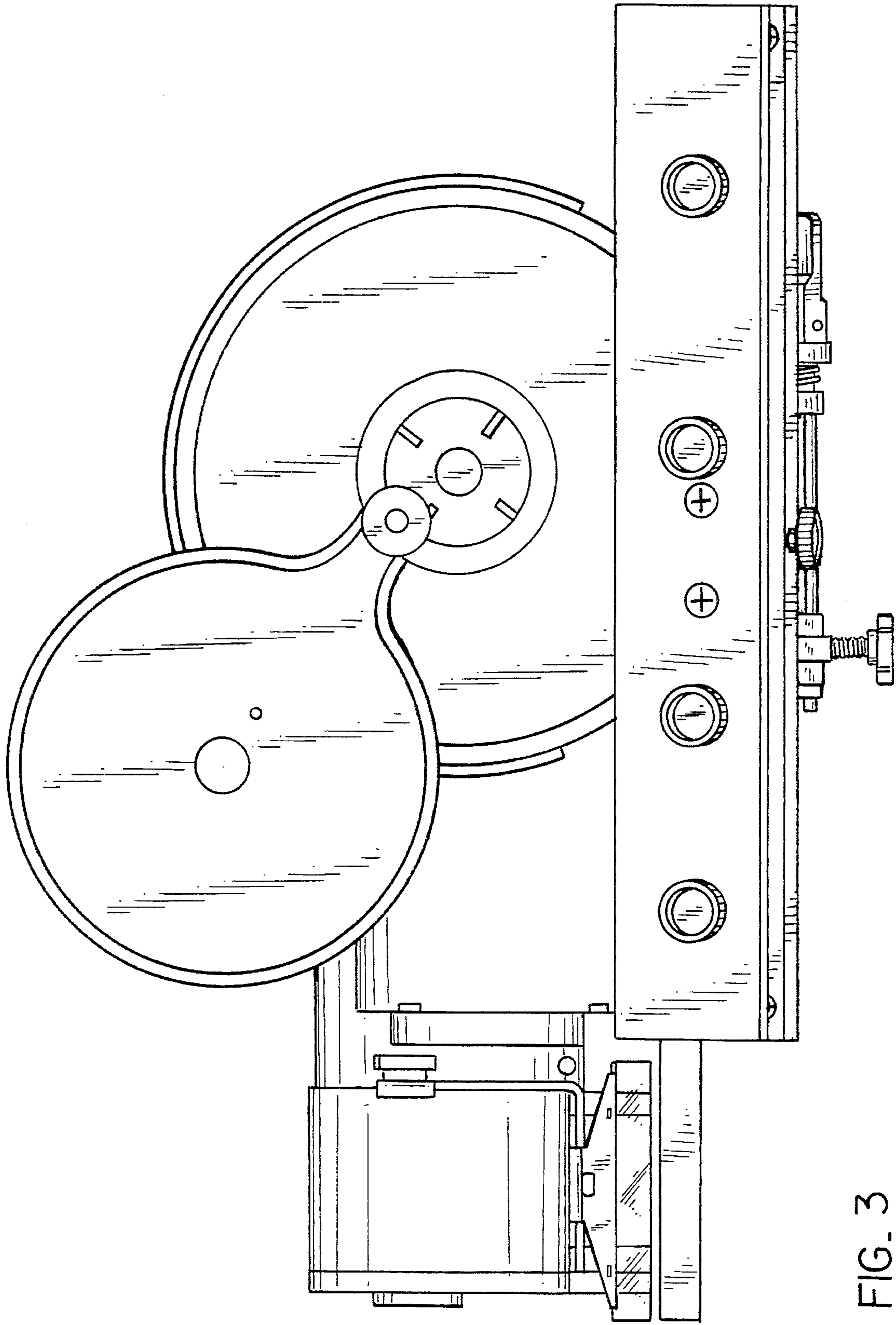

FIG. 3

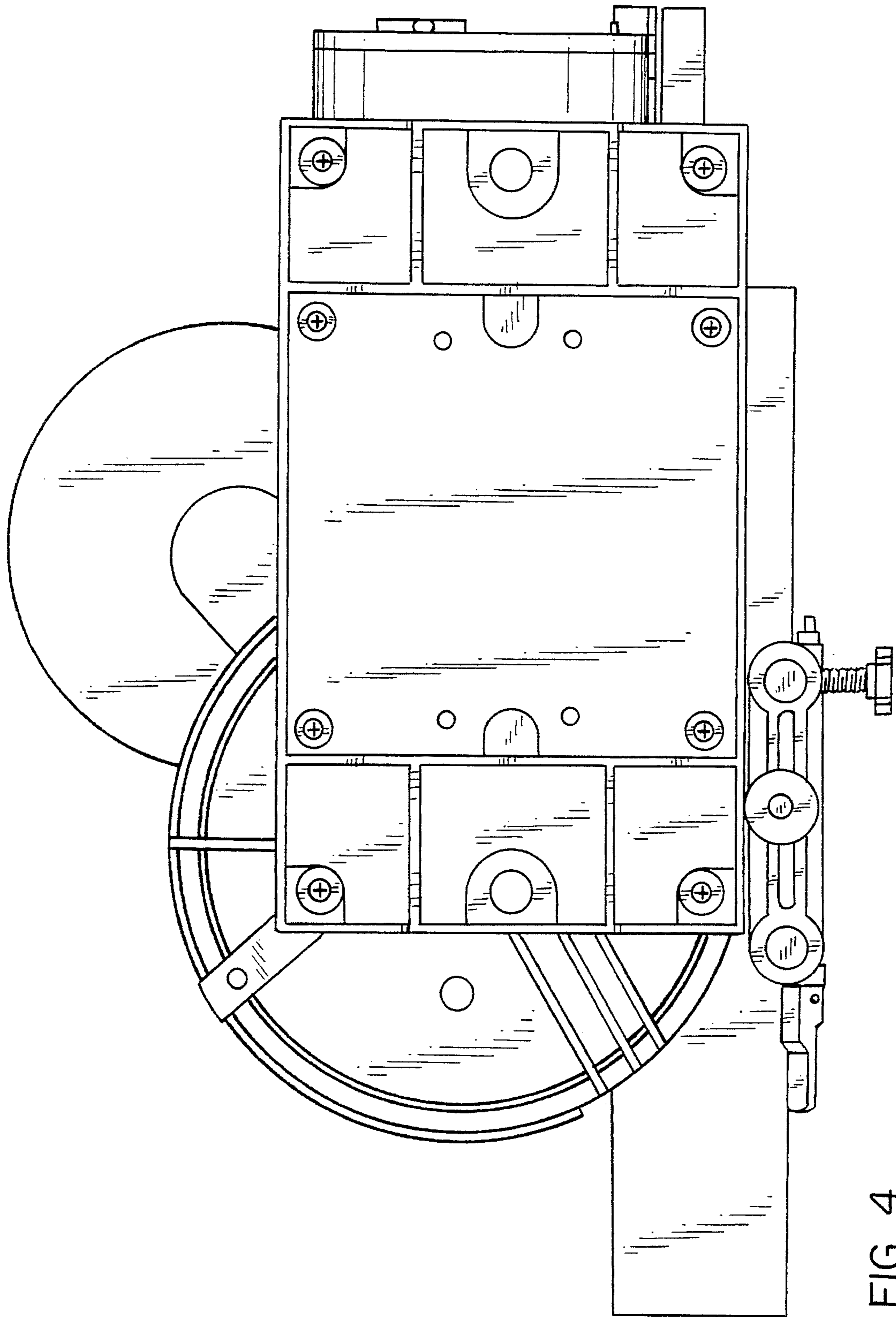

FIG. 4

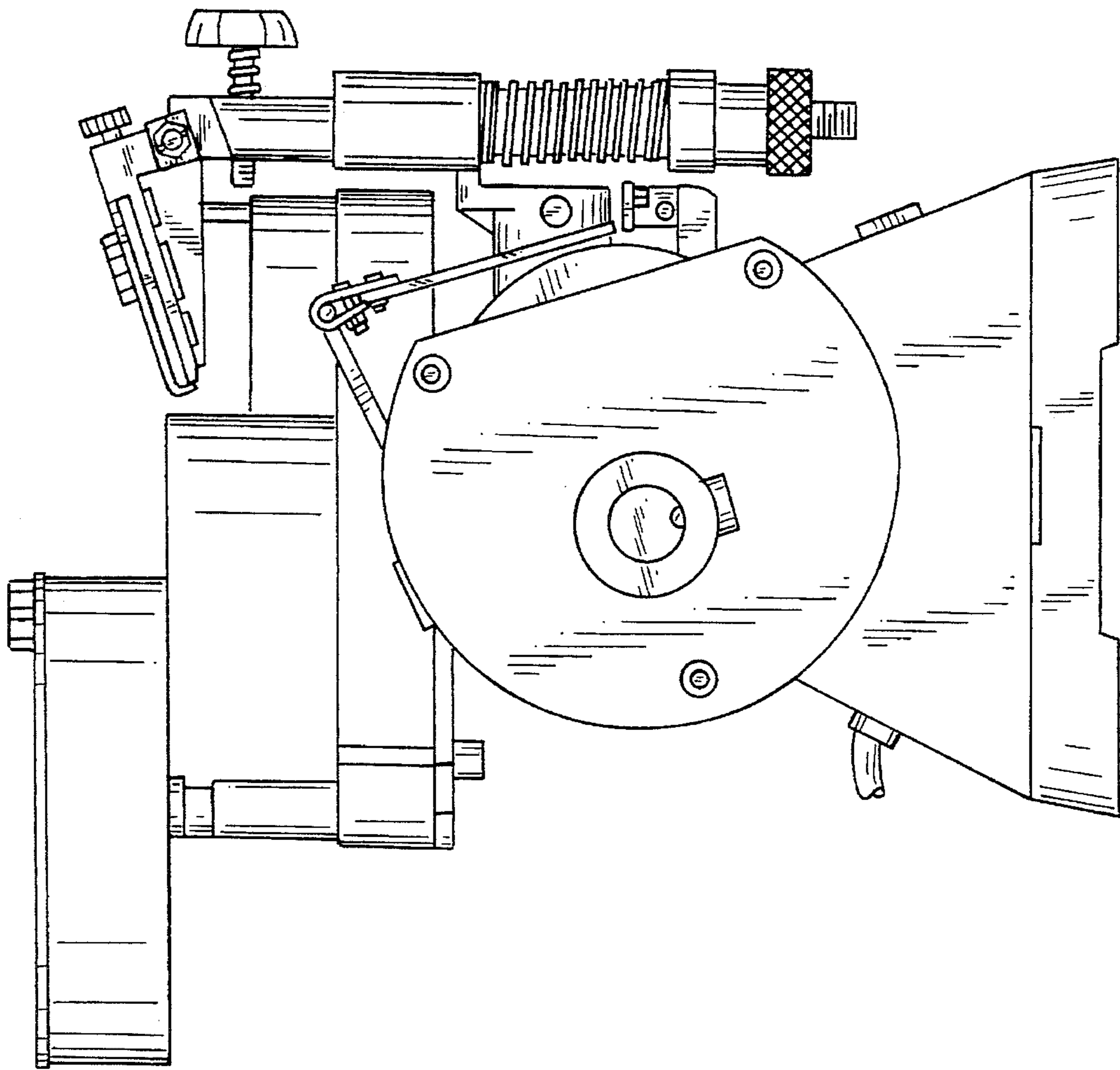

FIG. 5

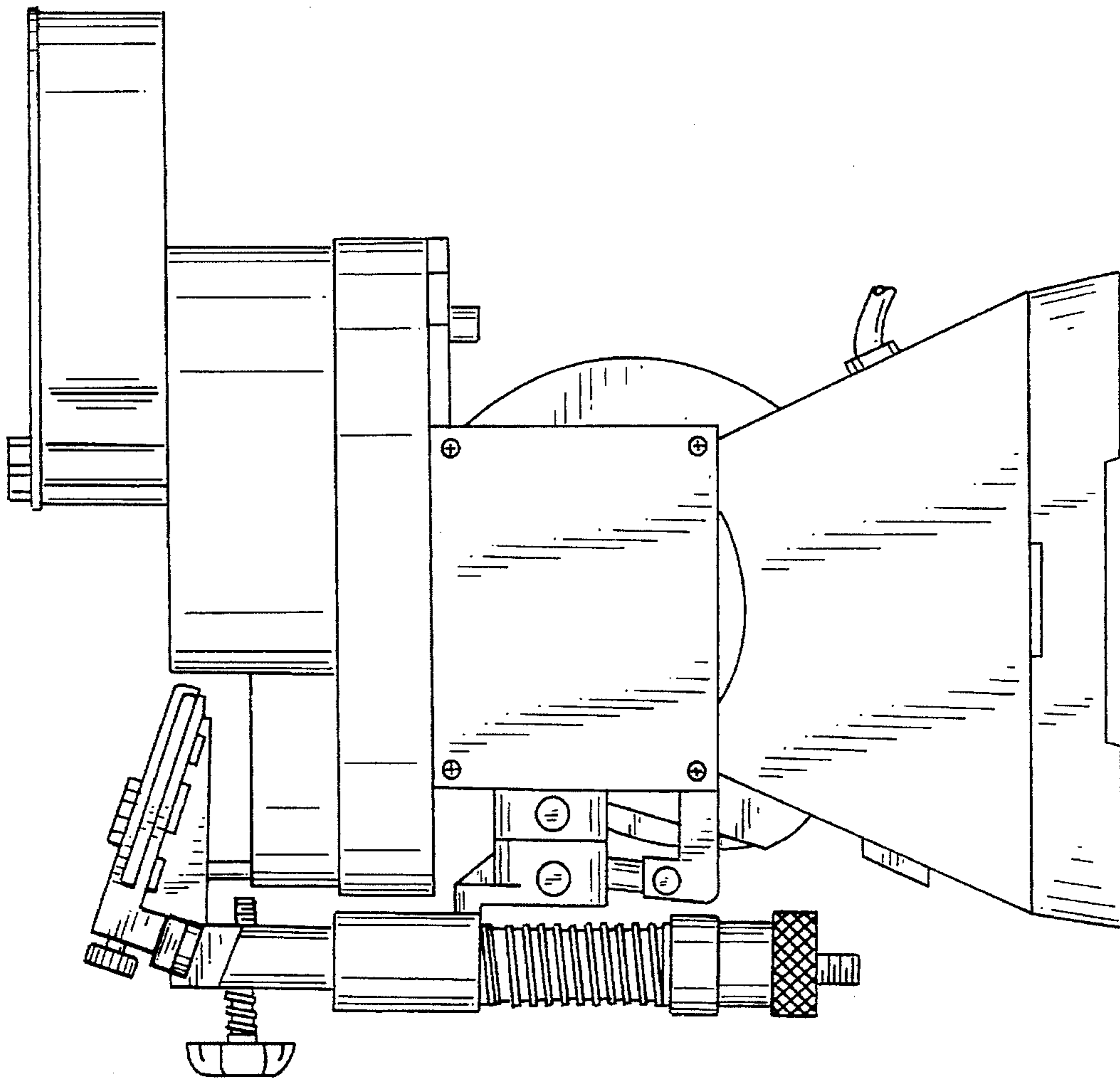

FIG. 6

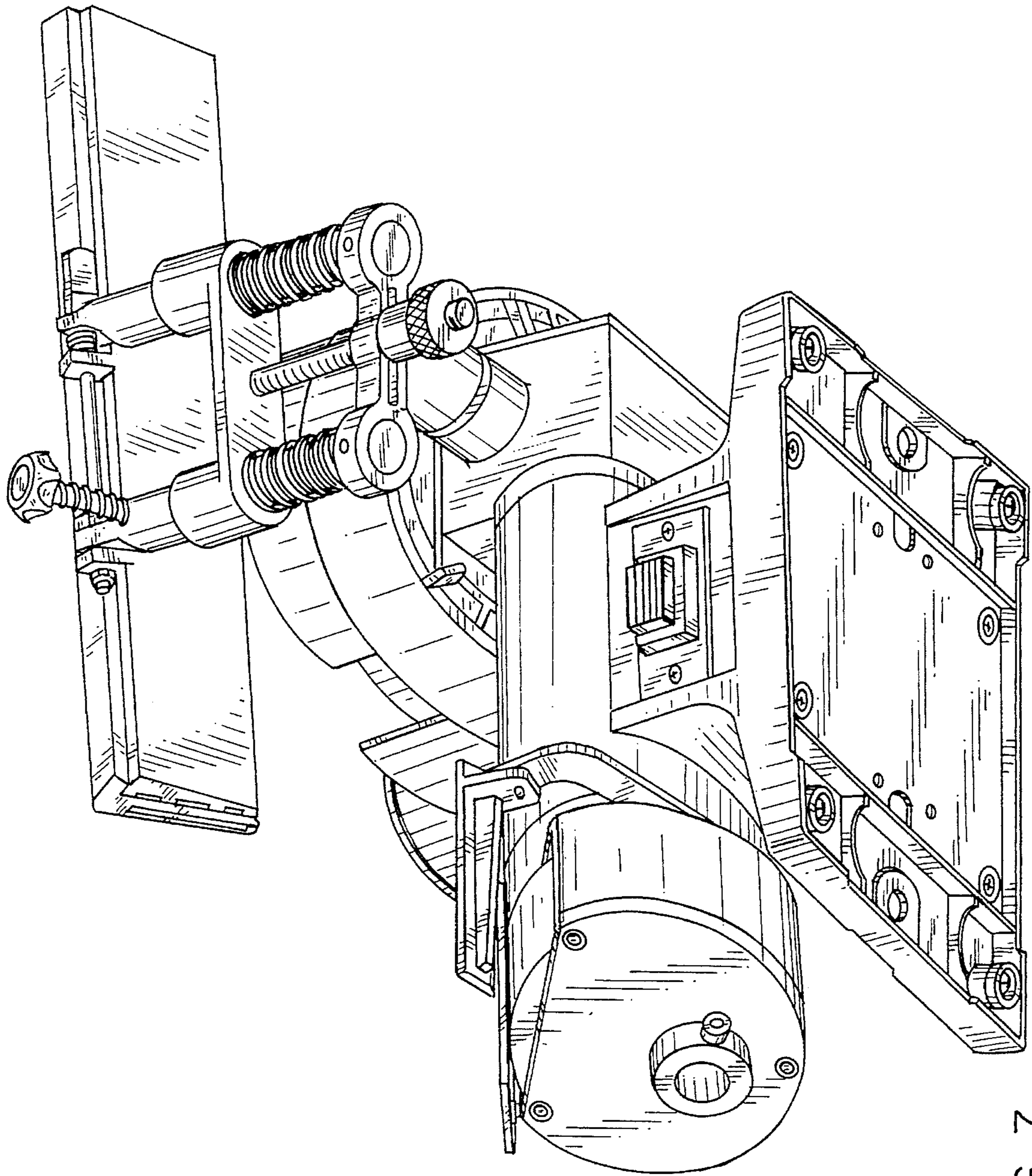

FIG. 7