



US00D366640S

# United States Patent [19]

Tucker et al.

[11] Patent Number: **Des. 366,640**

[45] Date of Patent: **\*\*Jan. 30, 1996**

## [54] TRUCK QUARTER FENDER

[75] Inventors: **Eric N. Tucker**, Denton, Tex.; **Ronaldo S. Natividad**, San Jose, Calif.

[73] Assignee: **Paccar Inc**, Bellevue, Wash.

[\*\*] Term: **14 Years**

[21] Appl. No.: **28,503**

[22] Filed: **Sep. 16, 1994**

[52] U.S. Cl. .... **D12/184**

[58] Field of Search ..... D12/184; 280/848, 280/849

## [56] References Cited

### U.S. PATENT DOCUMENTS

D. 282,834	3/1986	Matsui .....	D12/184
D. 307,254	4/1990	Koske et al. .	
D. 307,567	5/1990	Fingerele .	
D. 308,032	5/1990	Kerney et al. .	
D. 312,805	12/1990	Marlowe et al. .	
D. 316,241	4/1991	Ray .	
D. 321,160	10/1991	Kingsley .....	D12/184
D. 321,161	10/1991	Ueno .....	D12/184
D. 321,162	10/1991	Ueno .....	D12/184
4,932,716	1/1990	Marlowe et al. .	

## OTHER PUBLICATIONS

"Commercial Carrier Journal", Jul. 1992, p. 19.

*Primary Examiner*—Janice E. Seeger

*Assistant Examiner*—Cathron B. Matta

*Attorney, Agent, or Firm*—Flehr, Hohbach, Test, Albritton & Herbert

## [57] CLAIM

The ornamental design for truck quarter fender, as shown and described.

## DESCRIPTION

FIG. 1 is a top perspective view of a truck quarter fender showing our new design, it being understood that the phantom lines are for illustrative purposes only and form no part of the claimed design;

FIG. 2 is a front elevation view thereof;

FIG. 3 is a side elevation view of one side thereof;

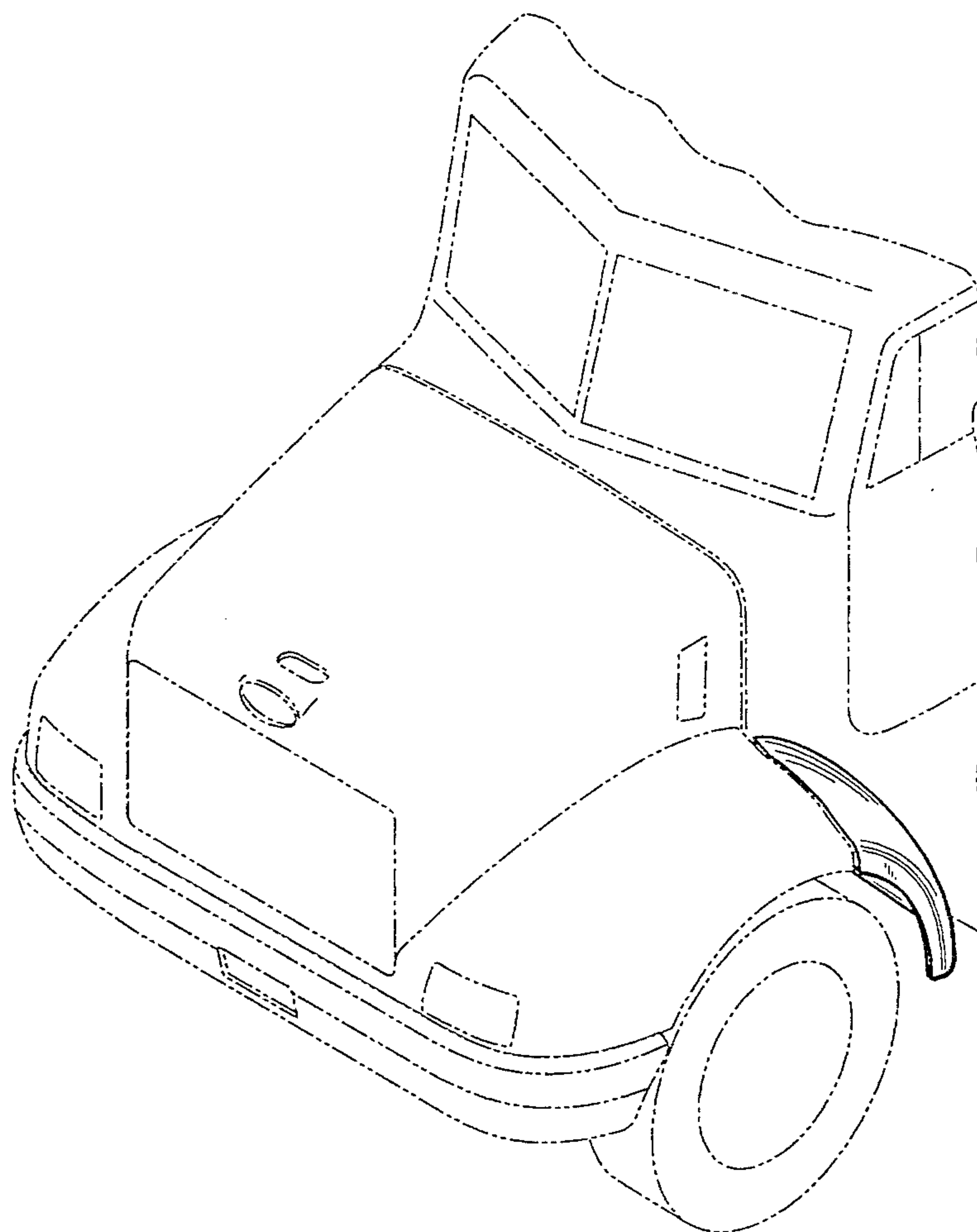
FIG. 4 is a rear elevation view thereof;

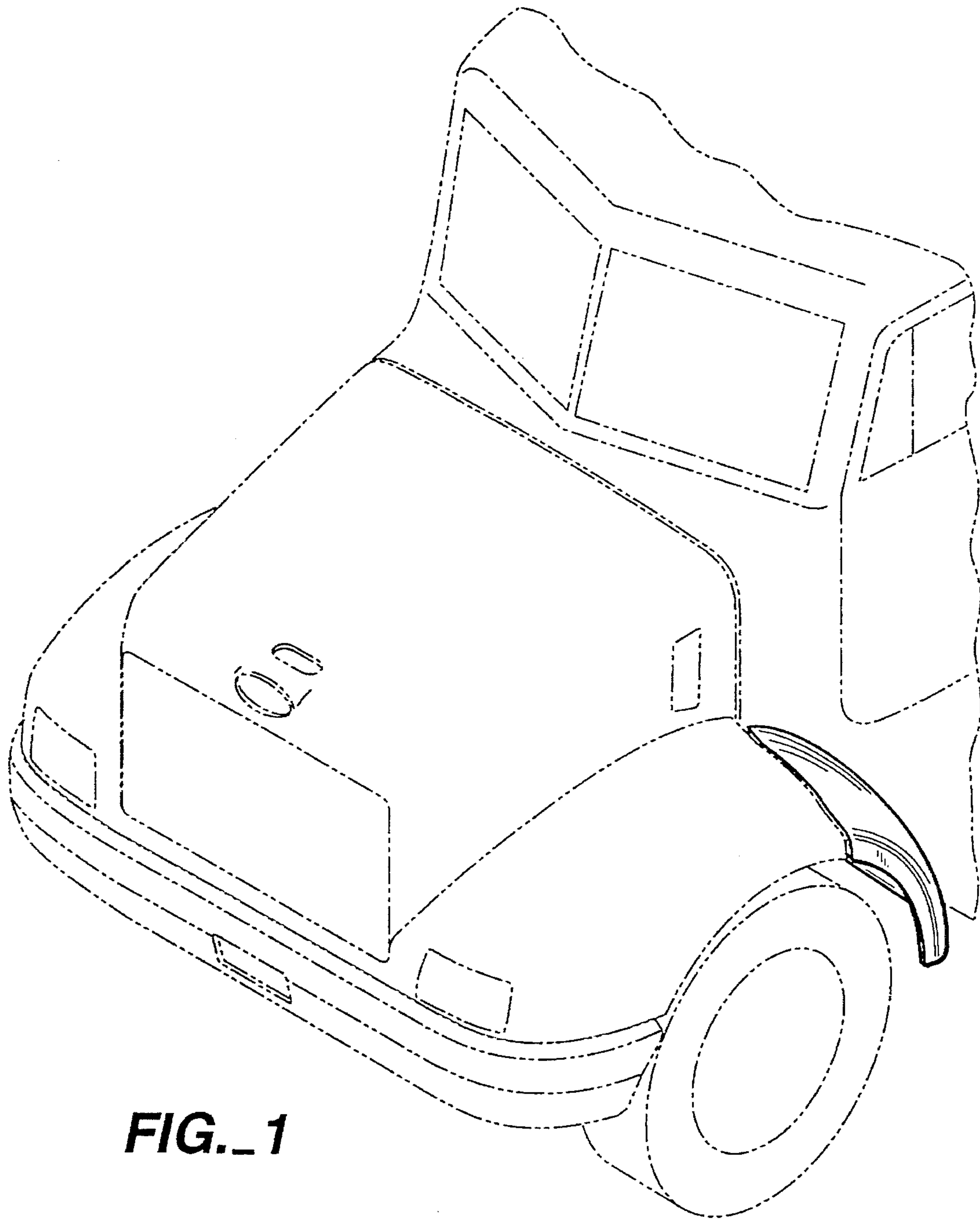
FIG. 5 is a side elevation view of the other side thereof;

FIG. 6 is a top plan view thereof; and,

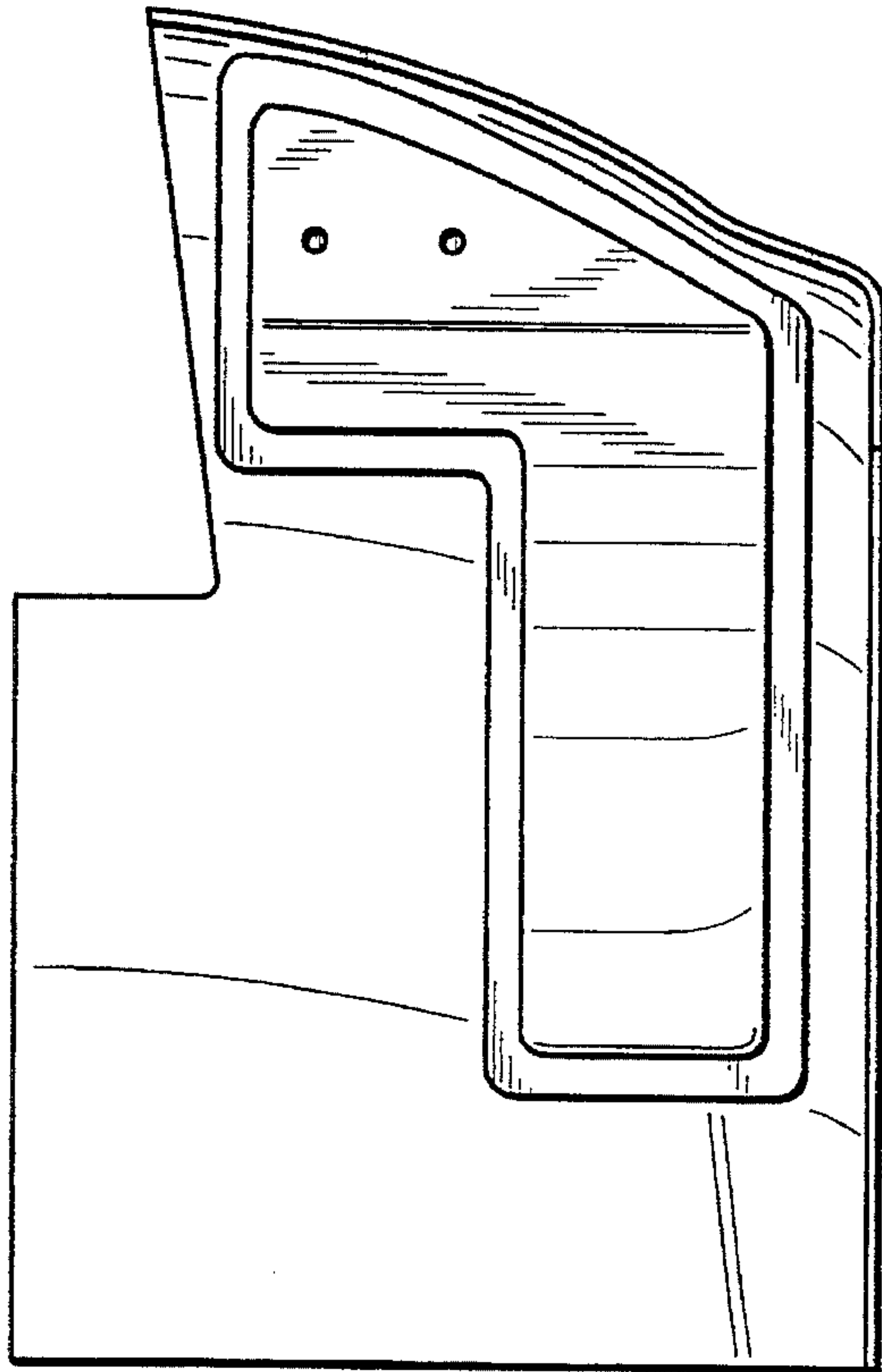
FIG. 7 is a bottom plan view thereof.

**1 Claim, 3 Drawing Sheets**

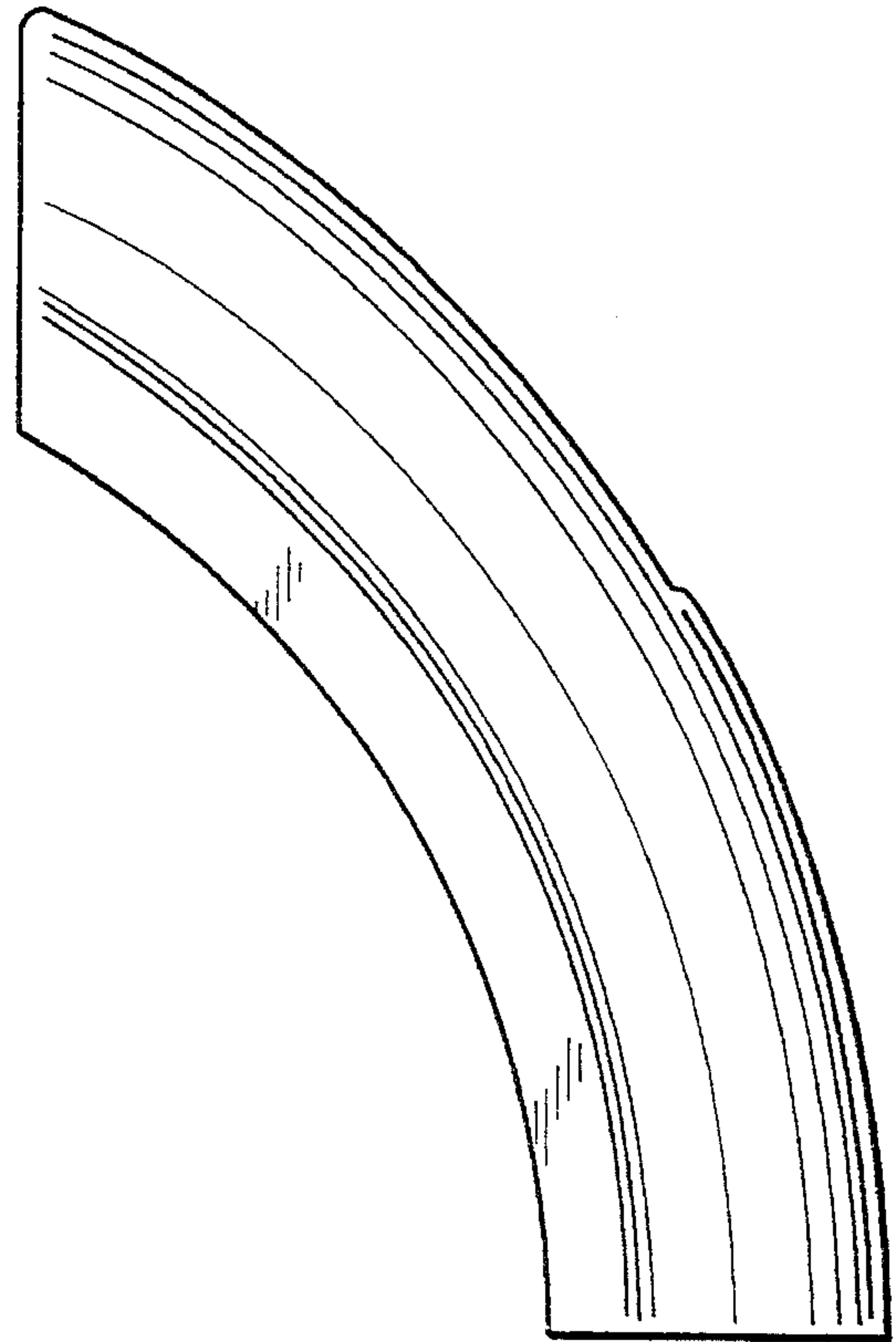




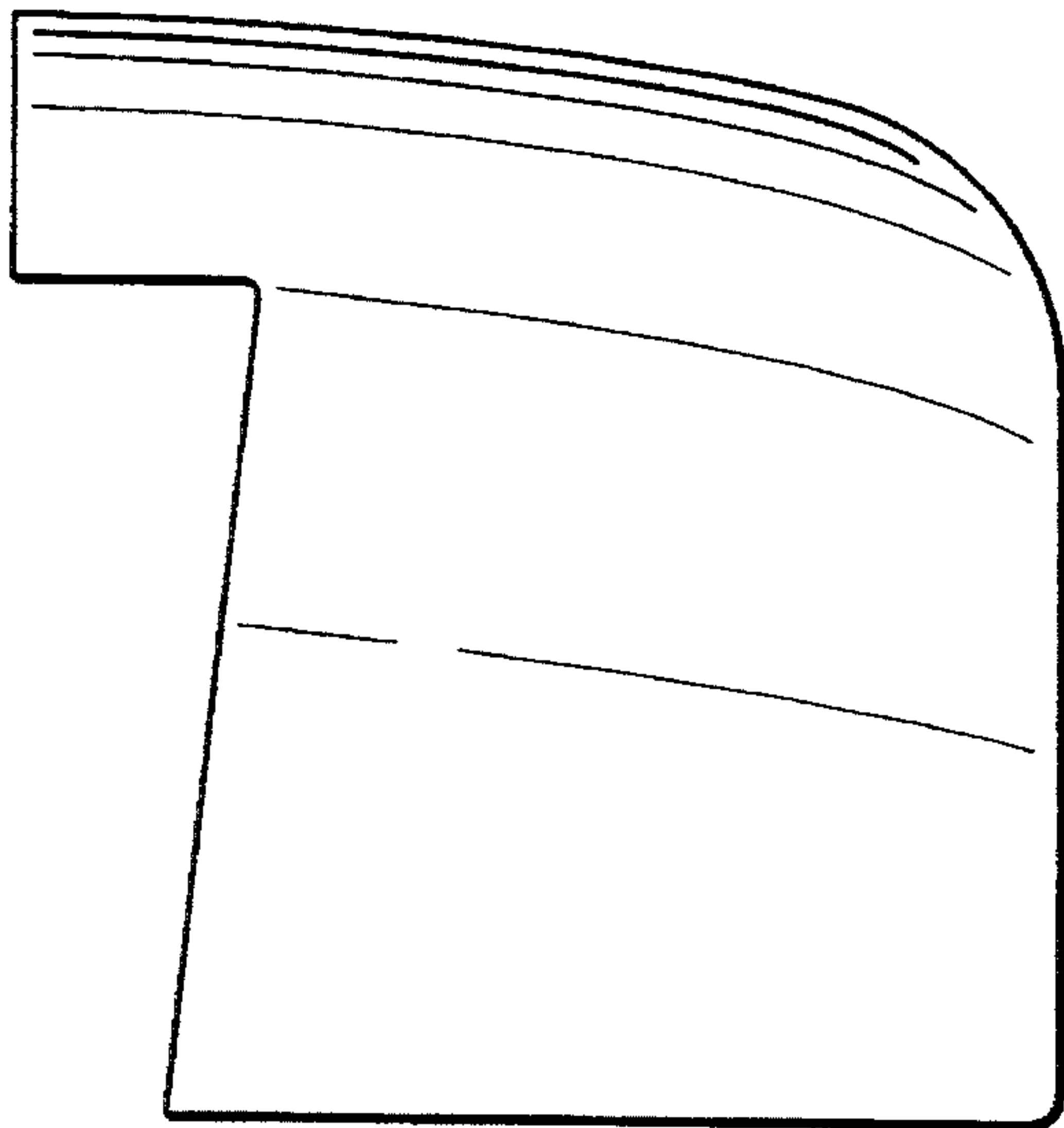
**FIG. 1**



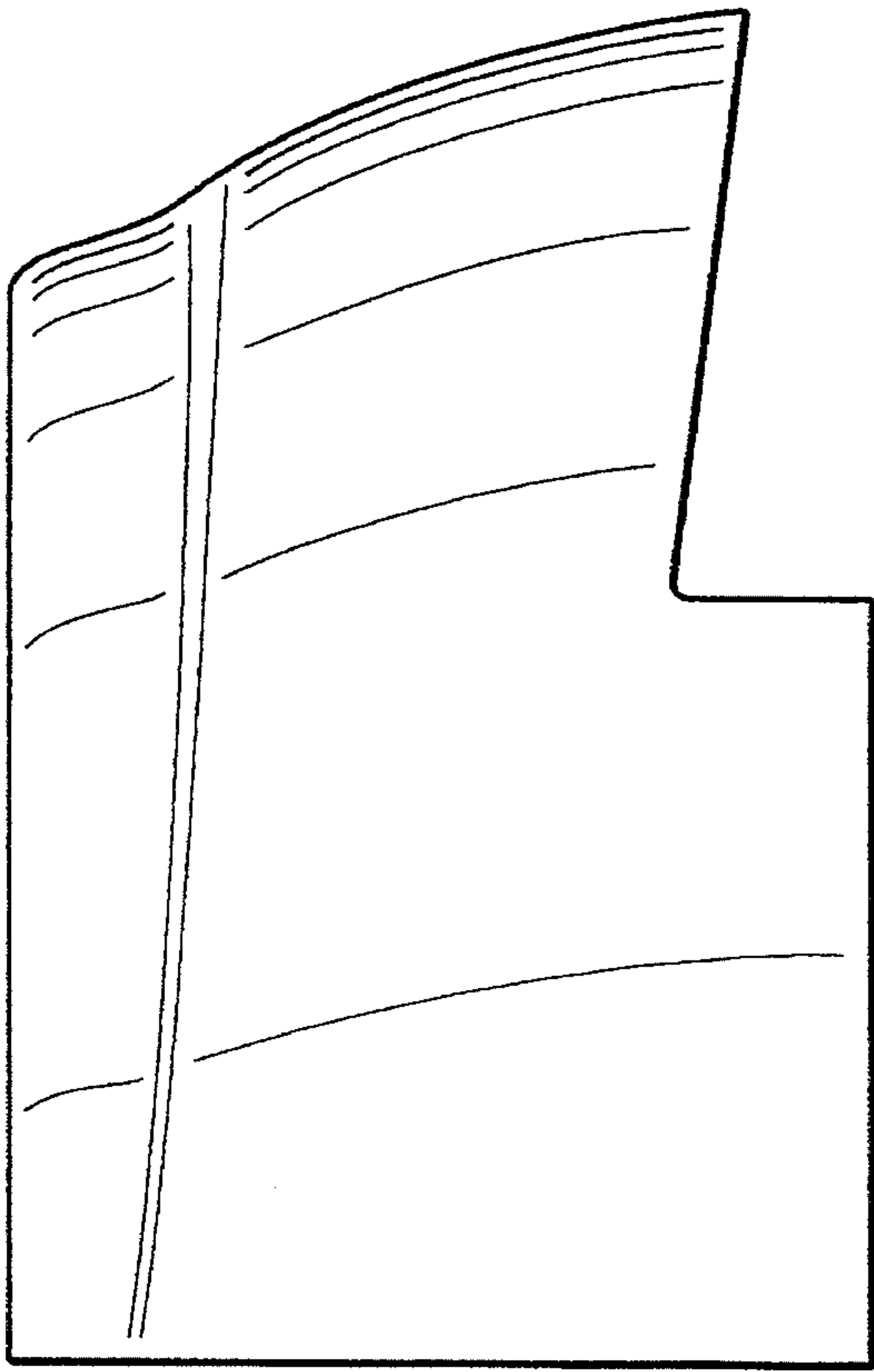
**FIG. 2**



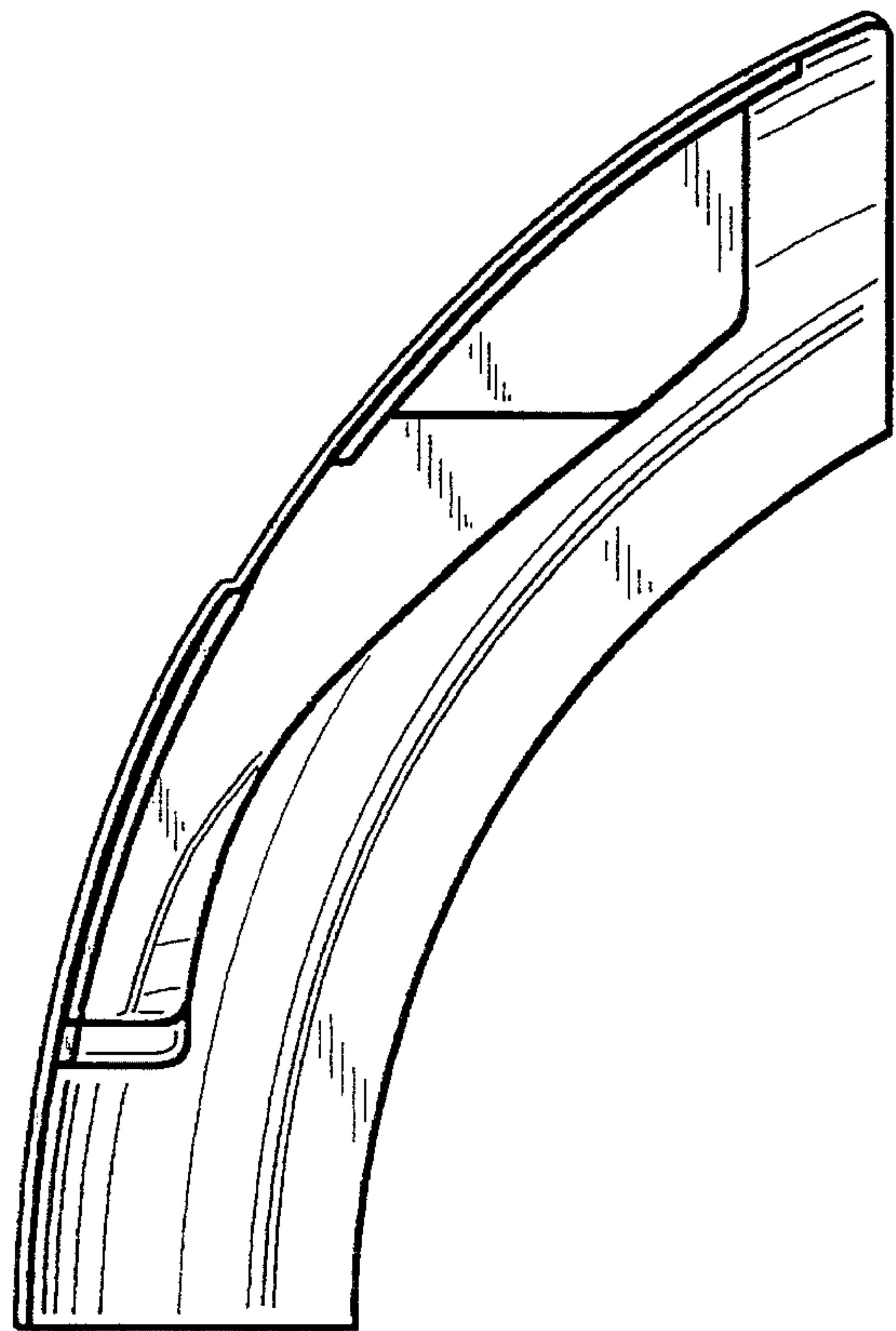
**FIG. 3**



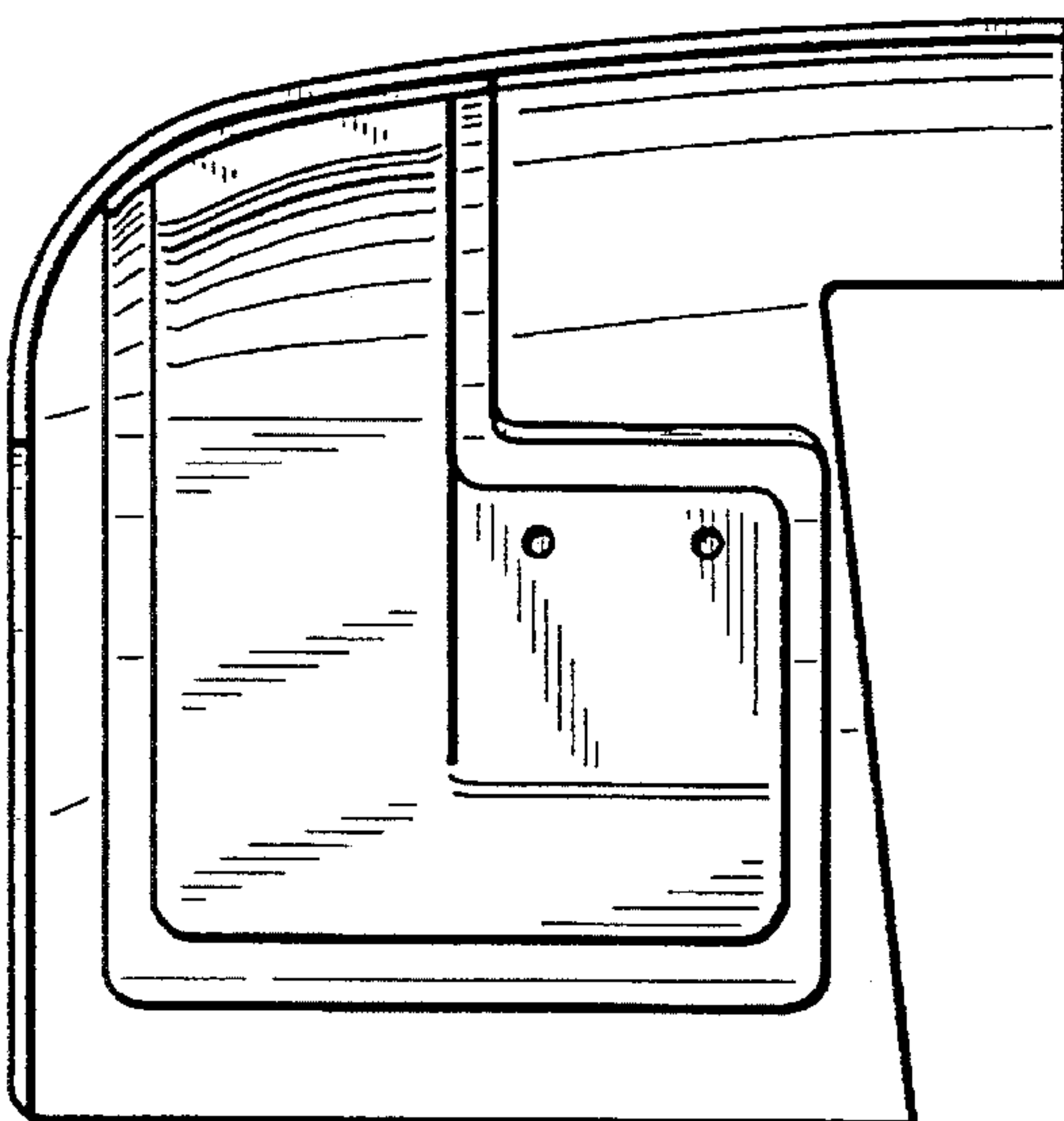
**FIG. 6**



**FIG.\_4**



**FIG.\_5**



**FIG.\_7**