



US00D366636S

# United States Patent [19] Smith

[11] Patent Number: **Des. 366,636**

[45] Date of Patent: **\*\*Jan. 30, 1996**

[54] **BICYCLE SAFETY UNIT FOR STUNT WHEELIES**

[76] Inventor: **Raymond Smith**, 26 Becker Ter.,  
Irvington, N.J. 07111

[\*\*] Term: **14 Years**

[21] Appl. No.: **24,617**

[22] Filed: **Jun. 17, 1994**

[52] U.S. Cl. .... **D12/114**

[58] Field of Search ..... D12/114, 101;  
280/288.4, 304.5, 304, 303, 293, 239, 292,  
205

[56] **References Cited**

**U.S. PATENT DOCUMENTS**

2,509,937	5/1950	Olson	.....	280/303
3,997,185	12/1976	Parrilla	.....	280/304.3
4,154,452	5/1979	Newman	.....	280/304
4,300,964	10/1987	Hess	.....	280/288.4
5,330,221	7/1994	Sutton	.....	280/293
5,368,323	11/1994	Young	.....	280/293

*Primary Examiner*—A. Hugo Word  
*Assistant Examiner*—M. Brown  
*Attorney, Agent, or Firm*—Kevin Sembra

[57] **CLAIM**

The ornamental design for a bicycle safety unit for stunt wheelies, as shown and described.

**DESCRIPTION**

FIG. 1 is a top and rear perspective view of a bicycle safety unit for stunt wheelies showing my new design;  
FIG. 2 is a left side, elevational view thereof, showing my new design, with the right side constituting a mirror-image of the left side;  
FIG. 3 is a front elevational view thereof;  
FIG. 4 is a rear elevational view thereof; and,  
FIG. 5 is a top plan view thereof.

The broken line illustration showing logo indicia positioning is for illustrative purposes only and forms no part of the claimed design.

**1 Claim, 3 Drawing Sheets**

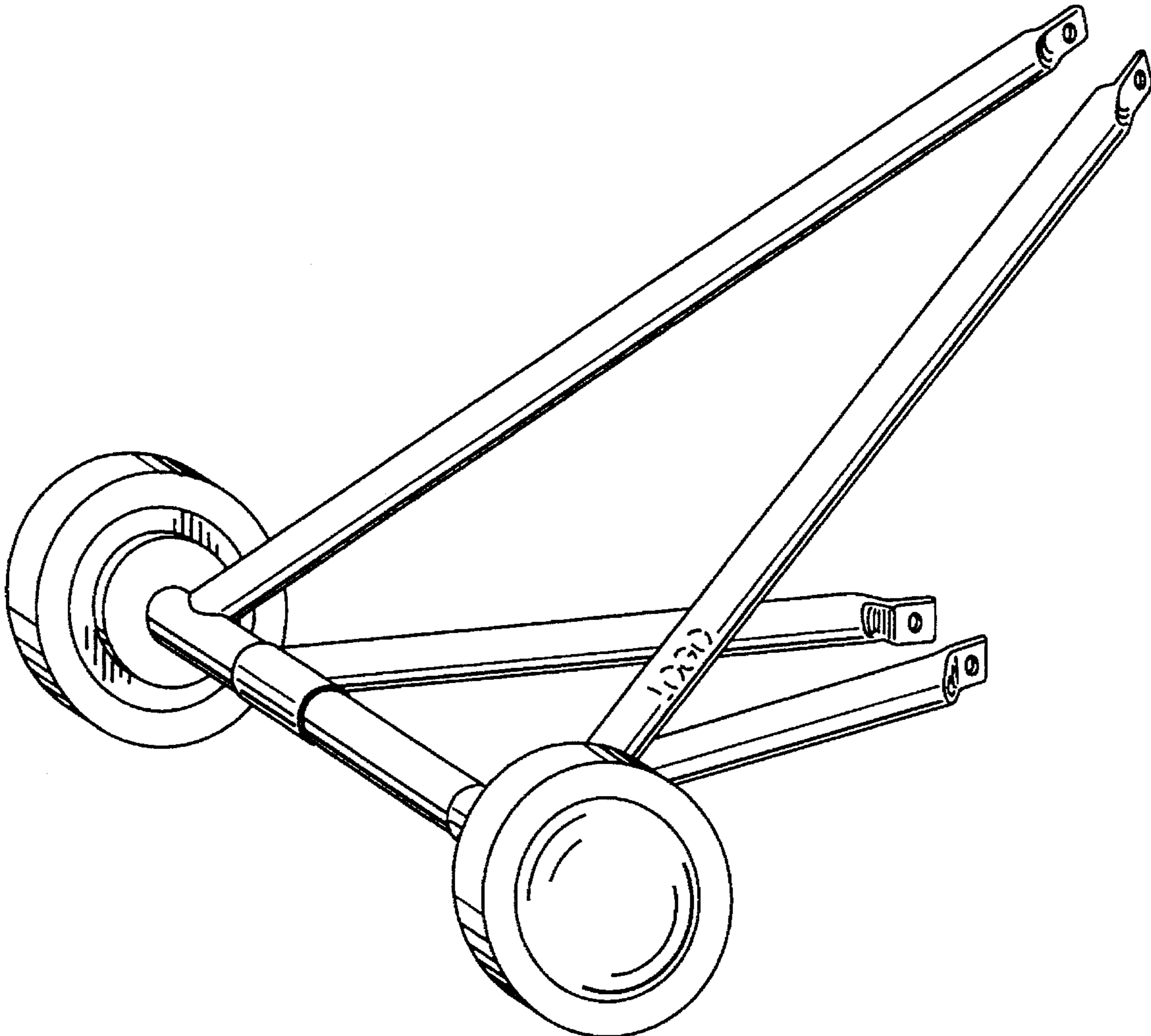

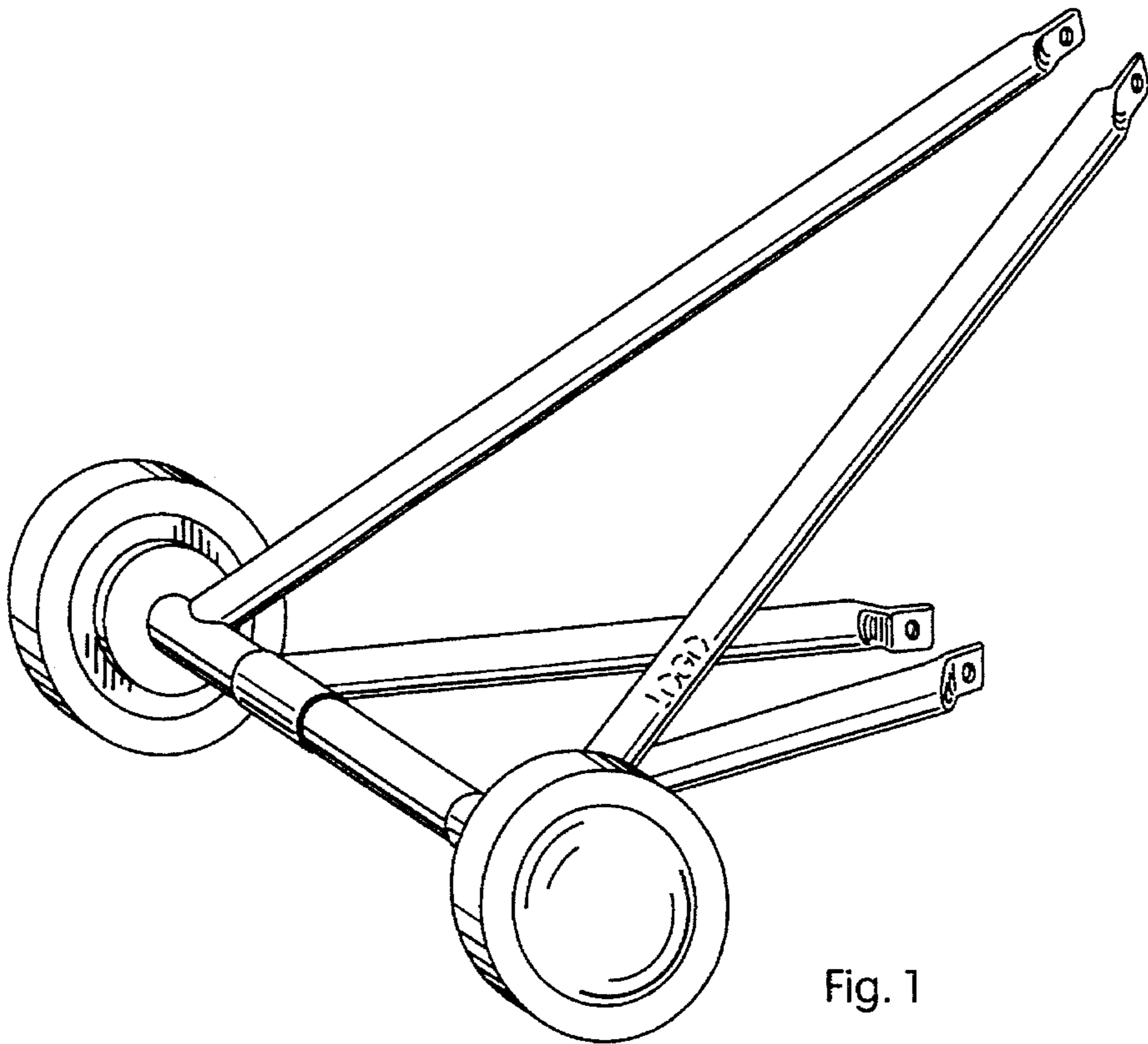

Fig. 1

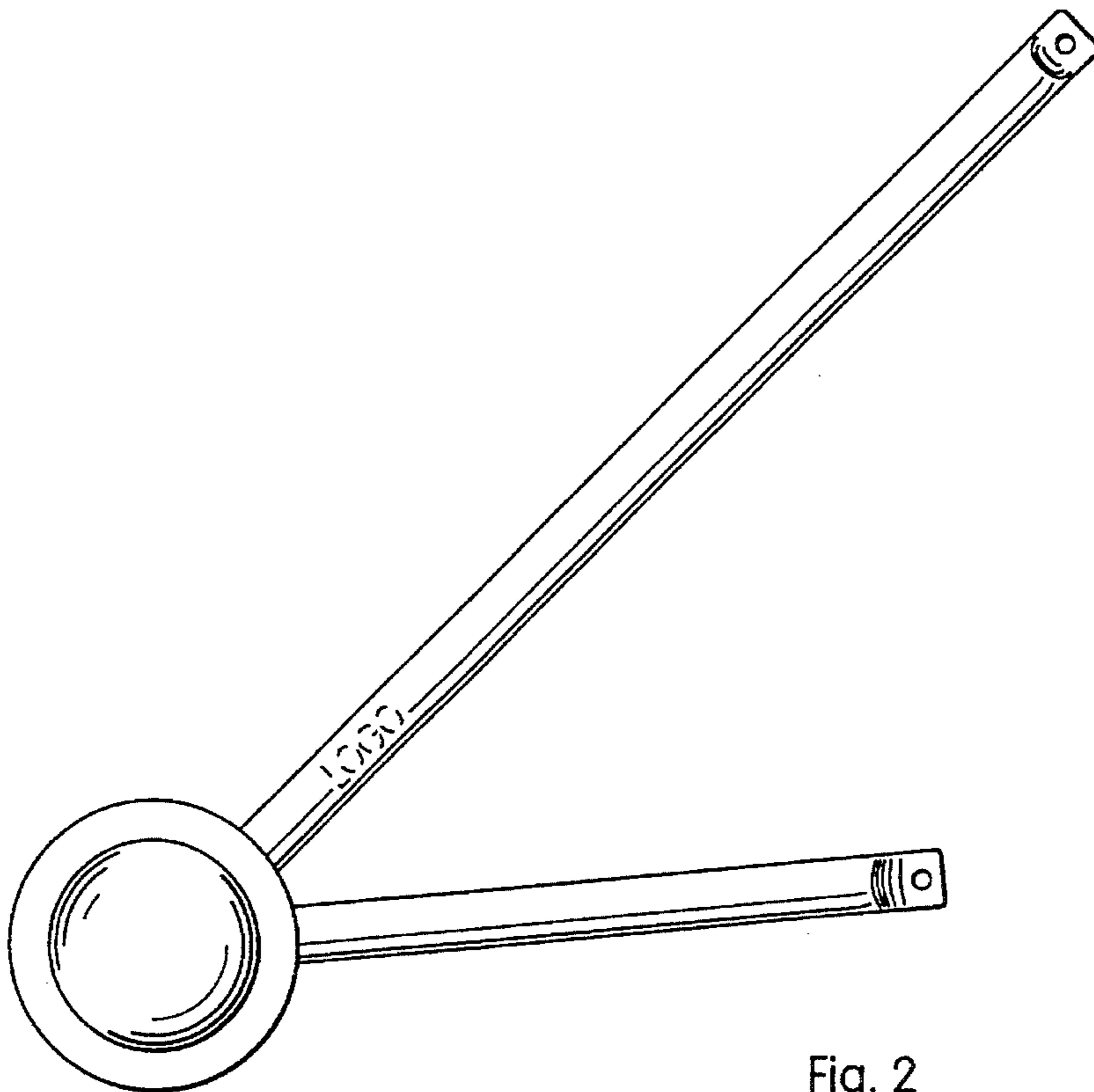

Fig. 2

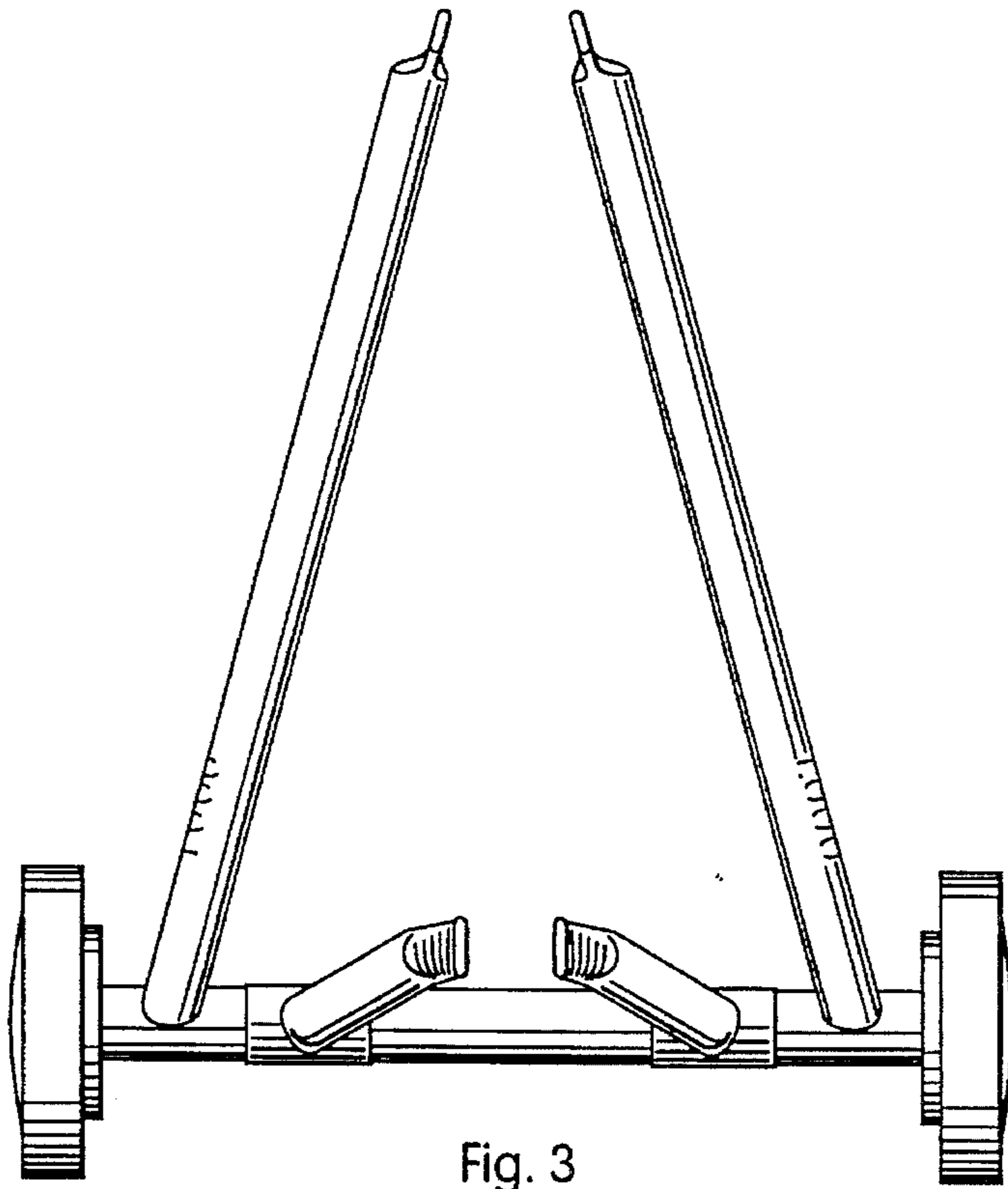

Fig. 3

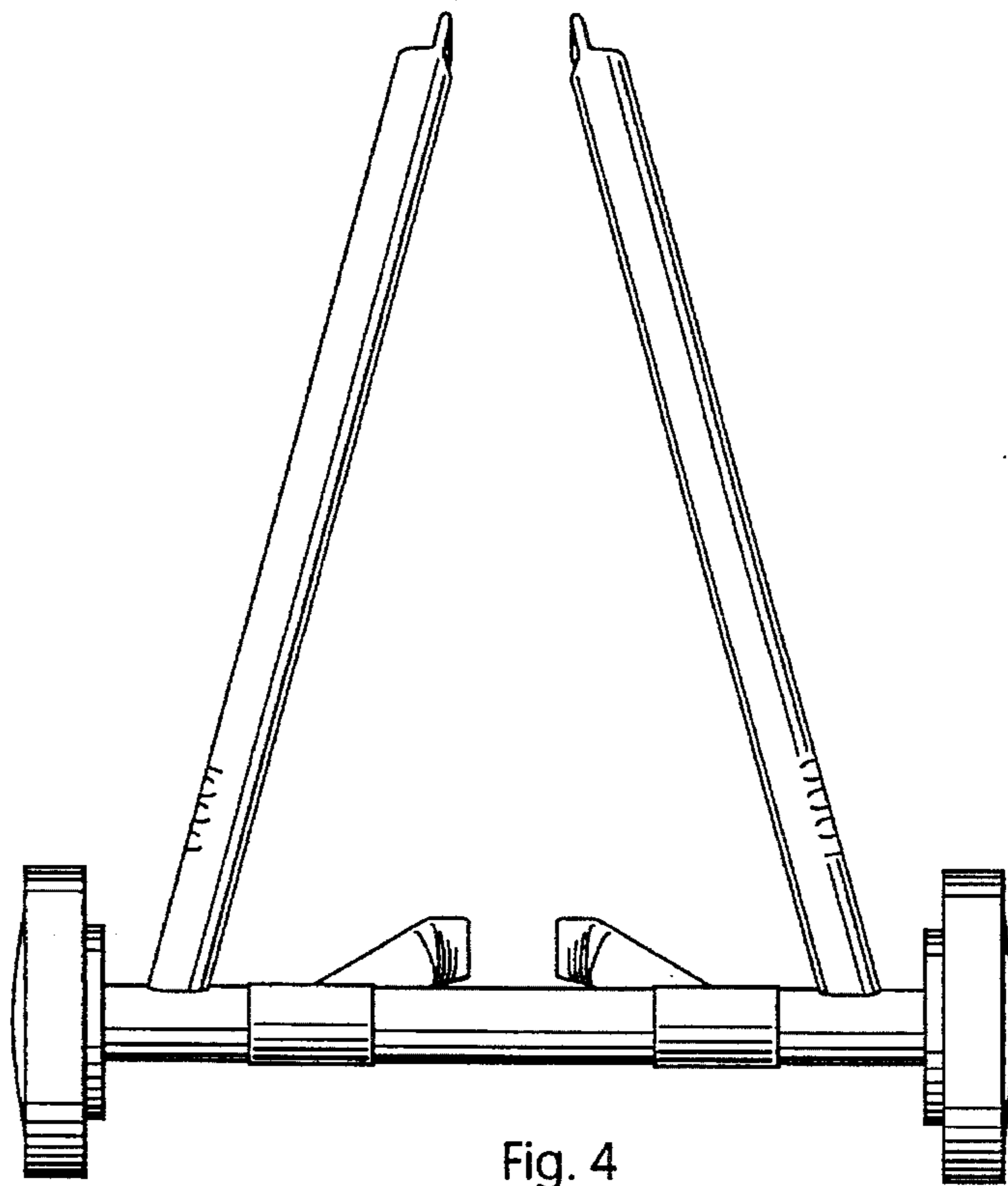

Fig. 4

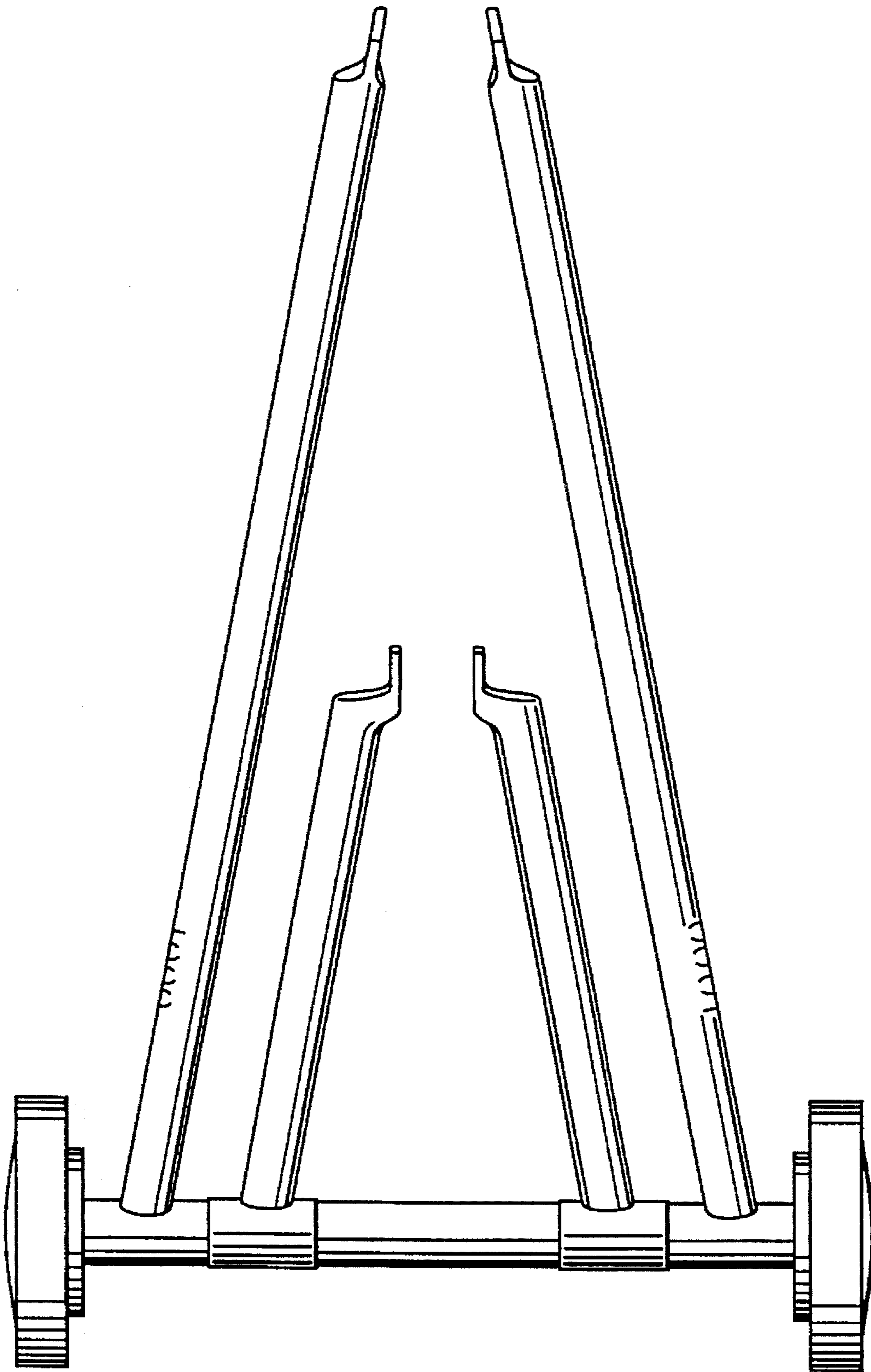

Fig. 5