



US00D366437S

United States Patent [19]
Johnson

[11] **Patent Number: Des. 366,437**

[45] **Date of Patent: **Jan. 23, 1996**

[54] **JET SKI LIFT FOR A TRAILER**

[76] Inventor: **Kelan D. Johnson**, 261 Lamar St.,
Myrtle Creek, Oreg. 97457

[**] Term: **14 Years**

[21] Appl. No.: **32,885**

[22] Filed: **Dec. 30, 1994**

[52] **U.S. Cl.** **D12/106**

[58] **Field of Search** D12/106; 414/462

[56] **References Cited**

U.S. PATENT DOCUMENTS

3,045,849	7/1962	Tweten	414/462
4,269,561	5/1981	Rutten .	
4,616,972	10/1986	McFarland .	
4,749,317	6/1988	Daniel .	
4,887,750	12/1989	Dainty	414/462 X
4,960,356	10/1990	Wrenn .	
5,005,846	4/1991	Taylor .	
5,071,308	12/1991	Tibbet .	
5,211,526	5/1993	Robinette .	
5,242,257	9/1993	Avakian	414/462
5,249,910	10/1993	Ball .	
5,257,728	11/1993	Gibson .	

Primary Examiner—A. Hugo Word

Assistant Examiner—Holly Baynham
Attorney, Agent, or Firm—Richard C. Litman

[57] **CLAIM**

The ornamental design for a jet ski lift for a trailer, as shown and described.

DESCRIPTION

FIG. 1 is a perspective view of a jet ski lift for a trailer showing my new design;

FIG. 2 is a front elevational view thereof;

FIG. 3 is a rear elevational view thereof;

FIG. 4 is a left side elevational view, with the right side being a mirror image thereof;

FIG. 5 is a bottom plan view thereof;

FIG. 6 is a top plan view thereof;

FIG. 7 is an environmental, side elevational view thereof, showing the lift fully raised, a jet ski supported thereon; and, FIG. 8 is an environmental, side elevational view thereof, showing the lift partially raised.

The broken line showing of a trailer, a boat, and a jet ski in FIGS. 7 and 8 is for illustrative purposes only and forms no part of the claimed design.

The contrasting cross-hatched shading shown on FIGS. 1–6 represents a cloth surface and is understood to cover the entire surface.

1 Claim, 8 Drawing Sheets

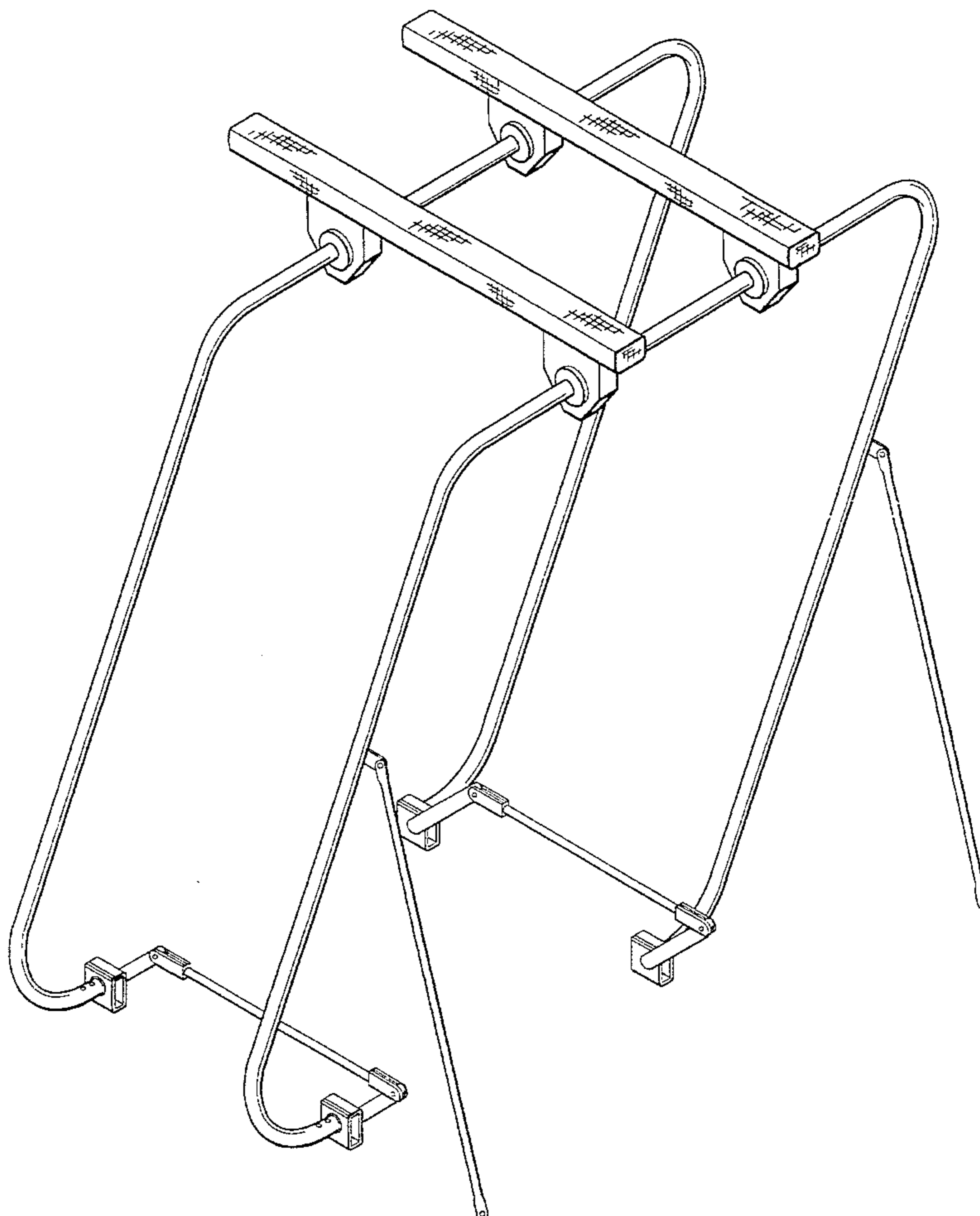

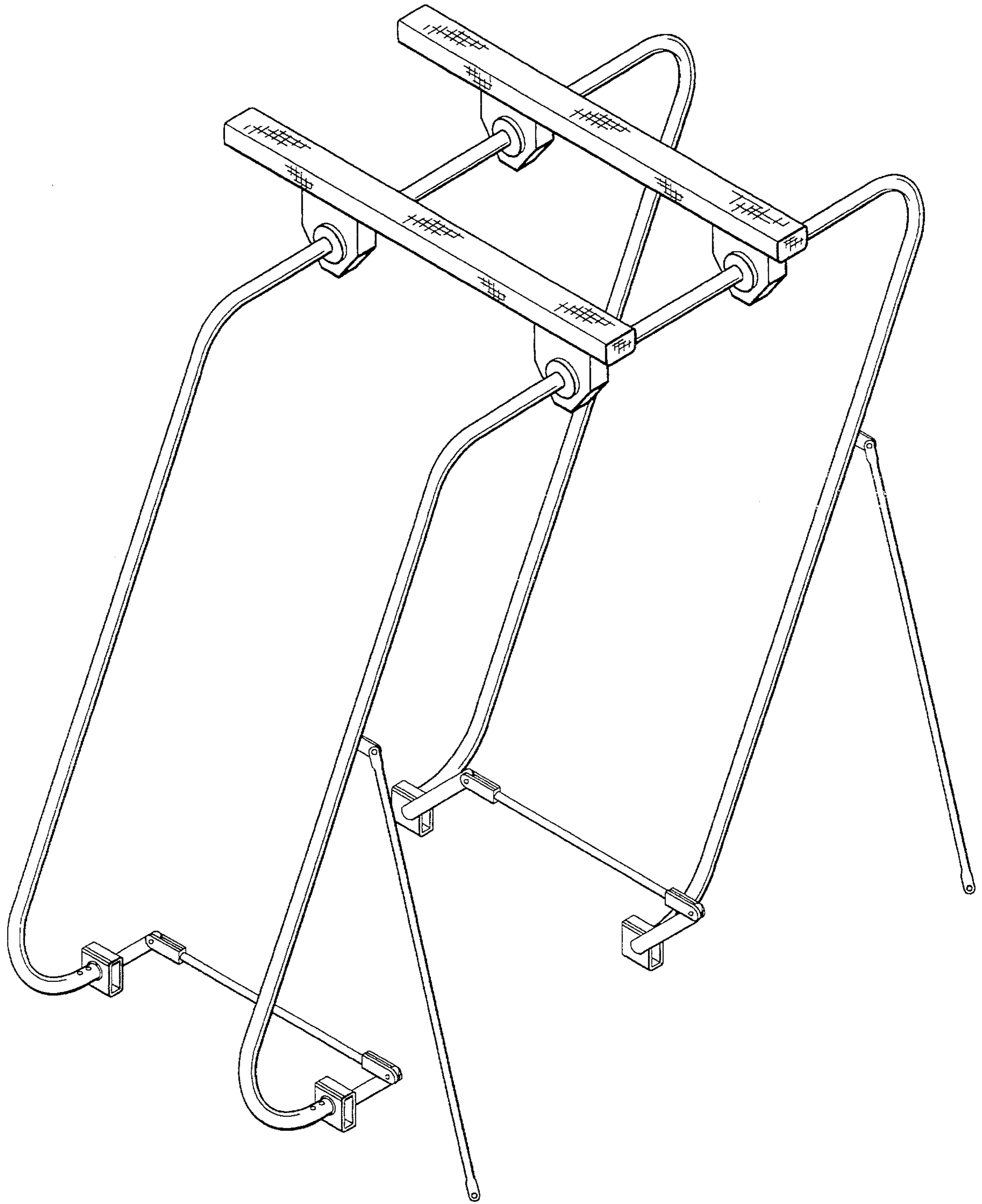

FIG. 1

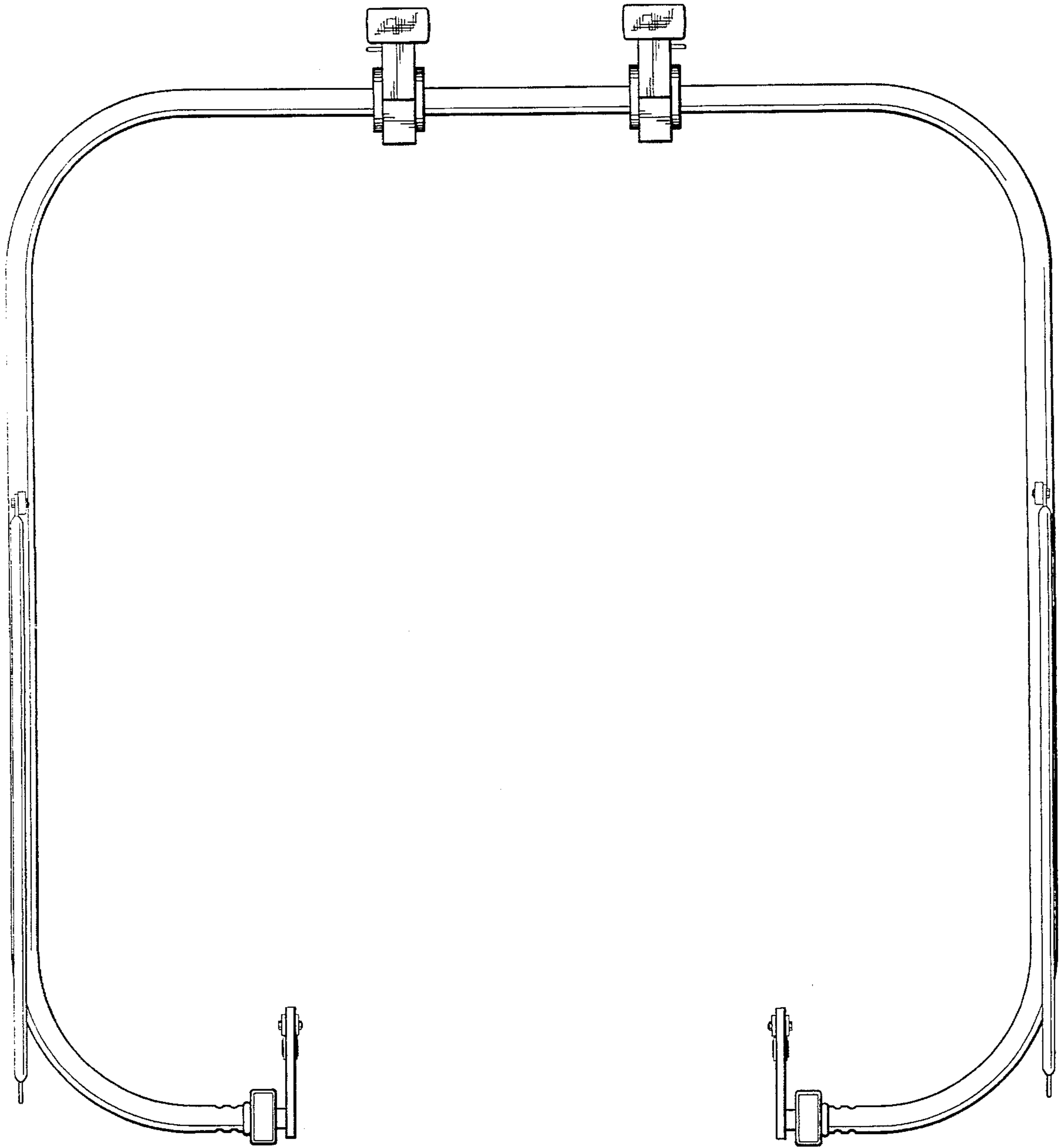

FIG. 2

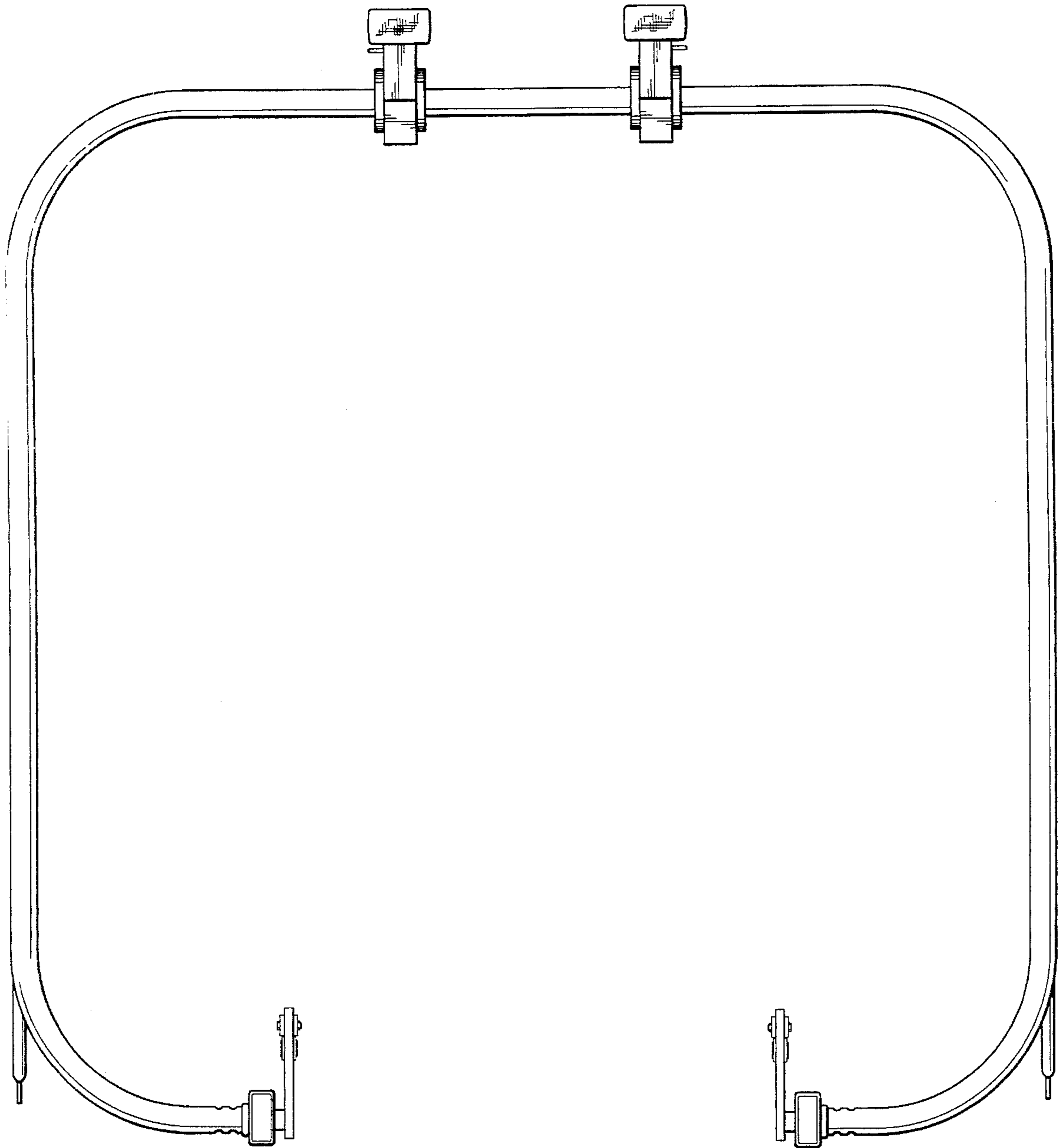

FIG. 3

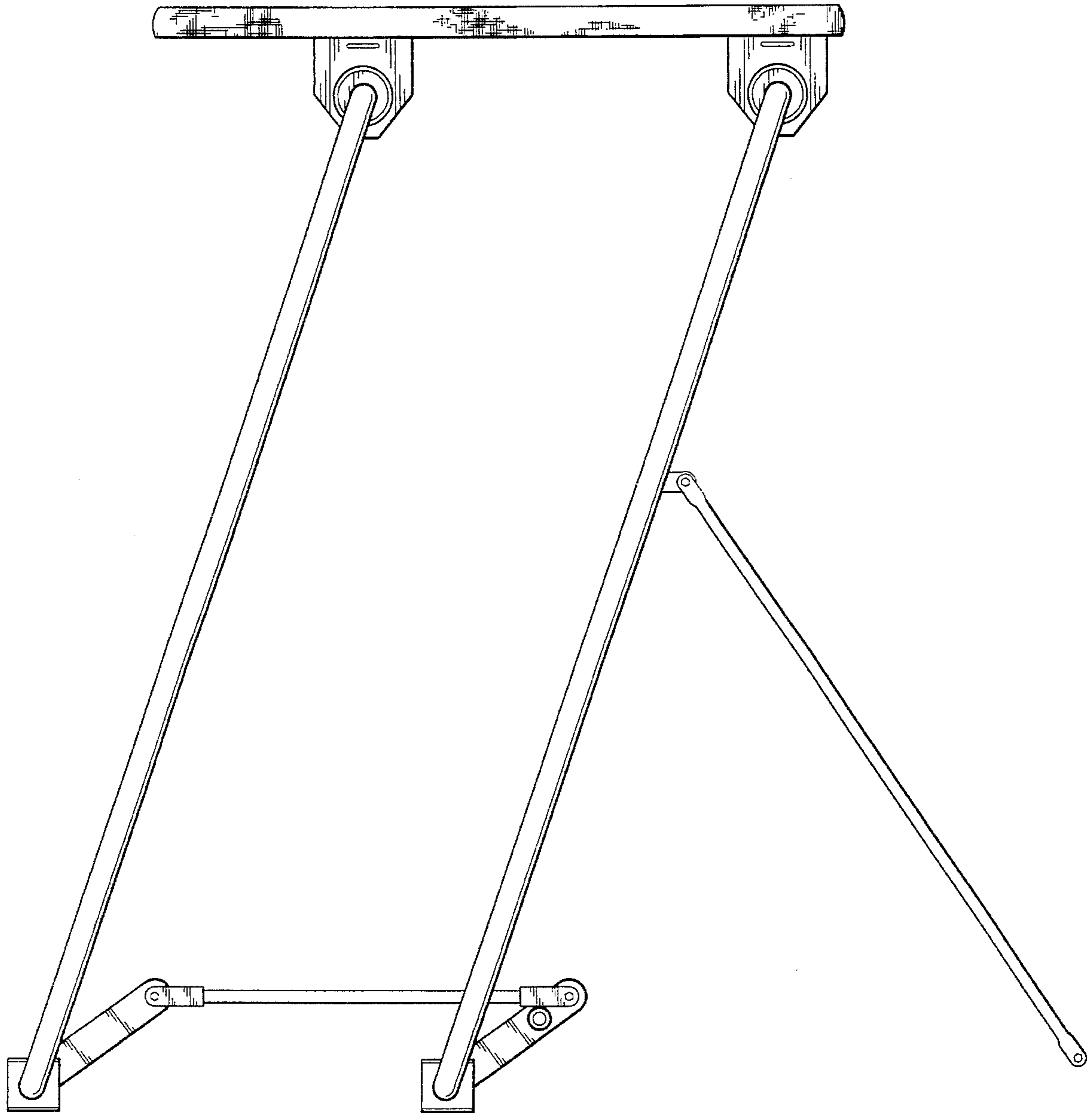

FIG. 4

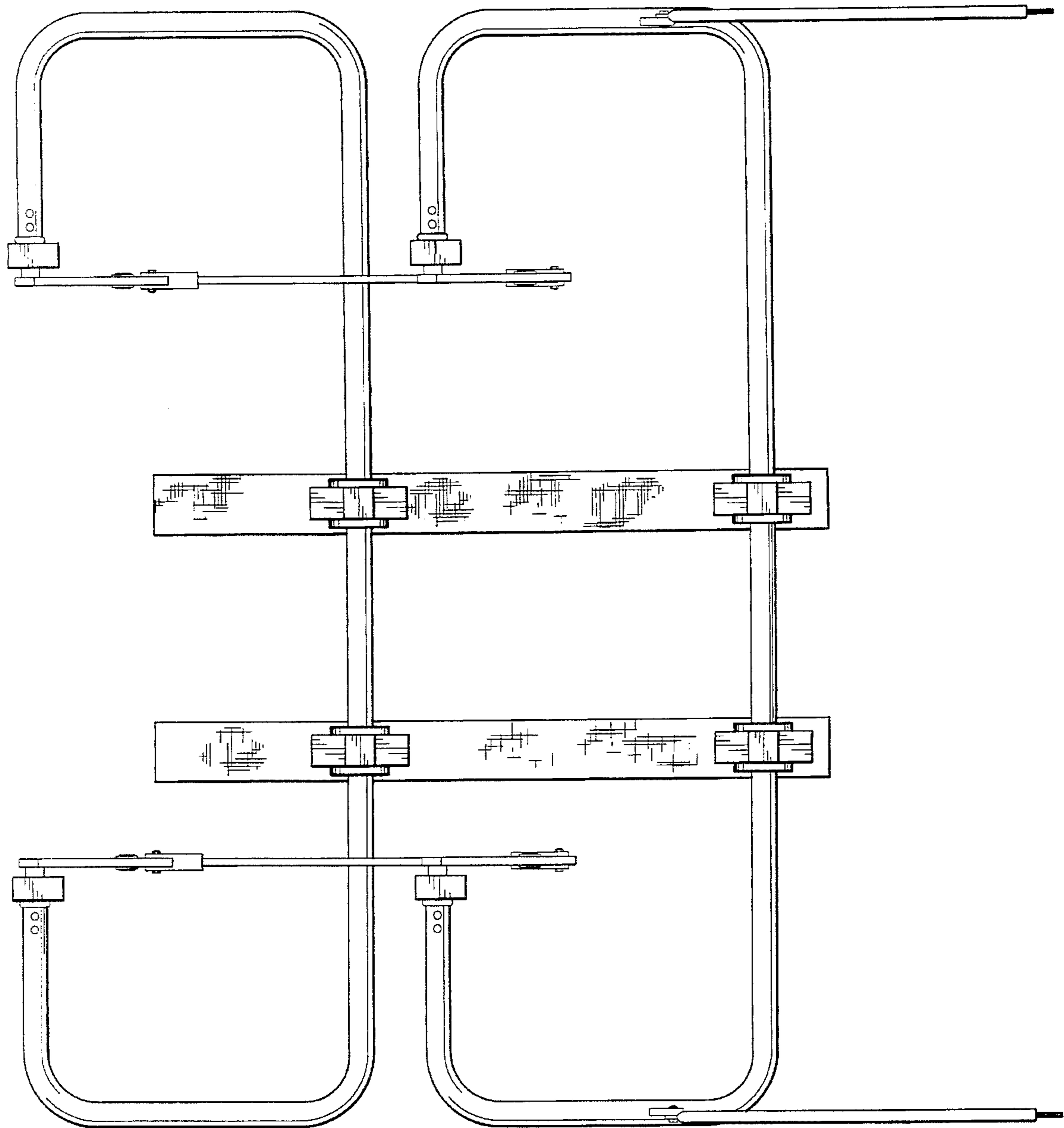

FIG. 5

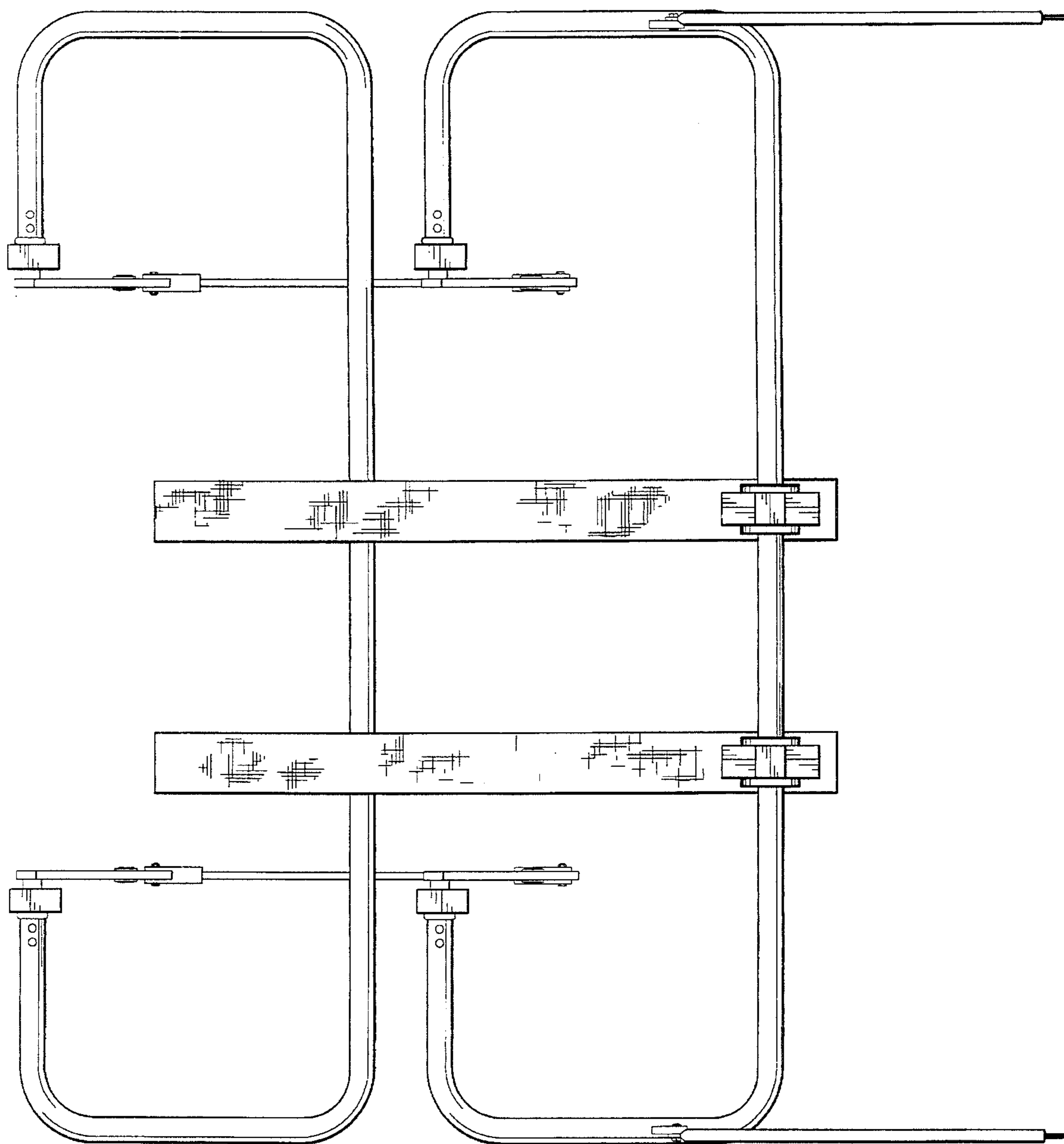

FIG. 6

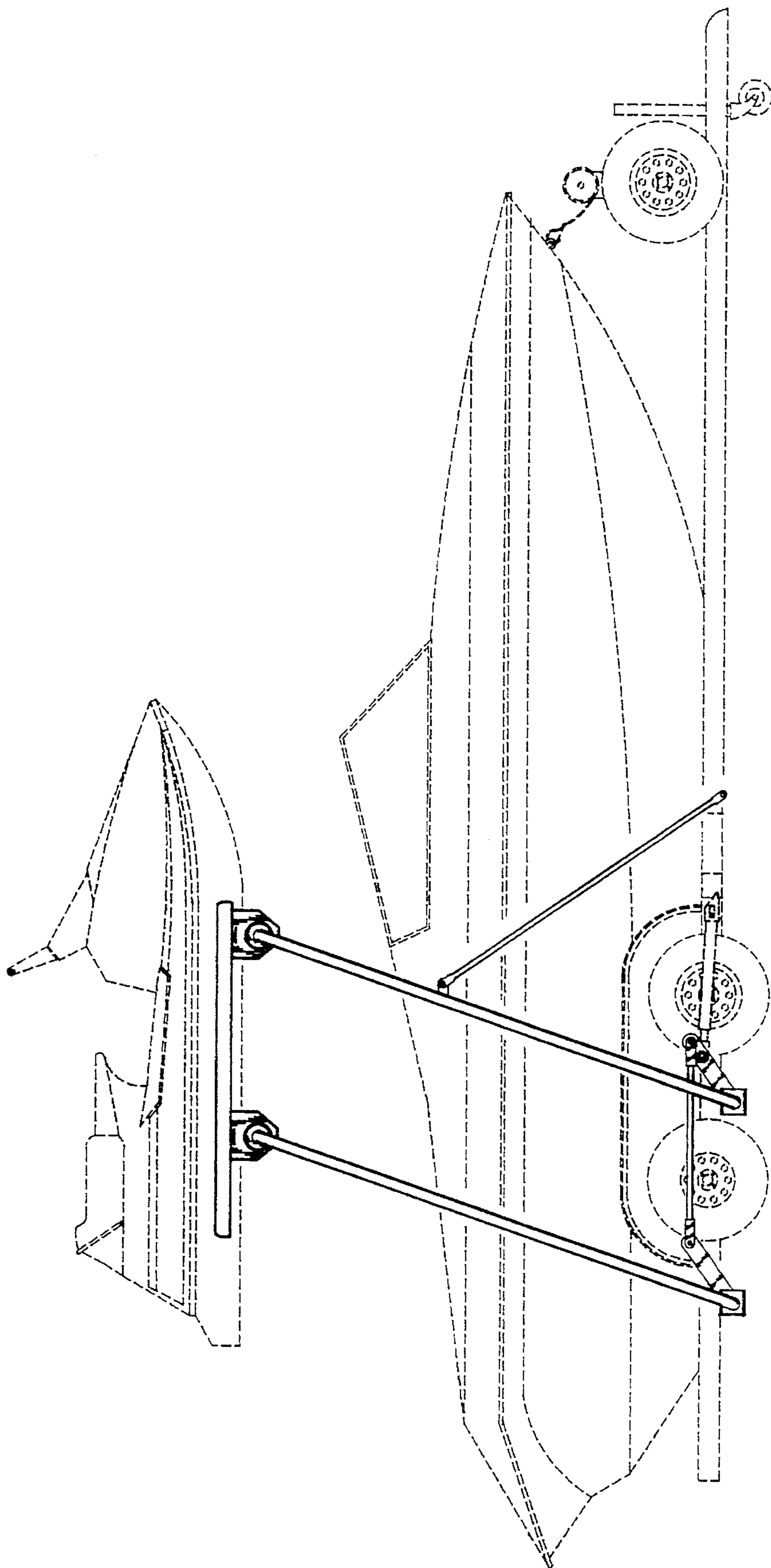

FIG. 7

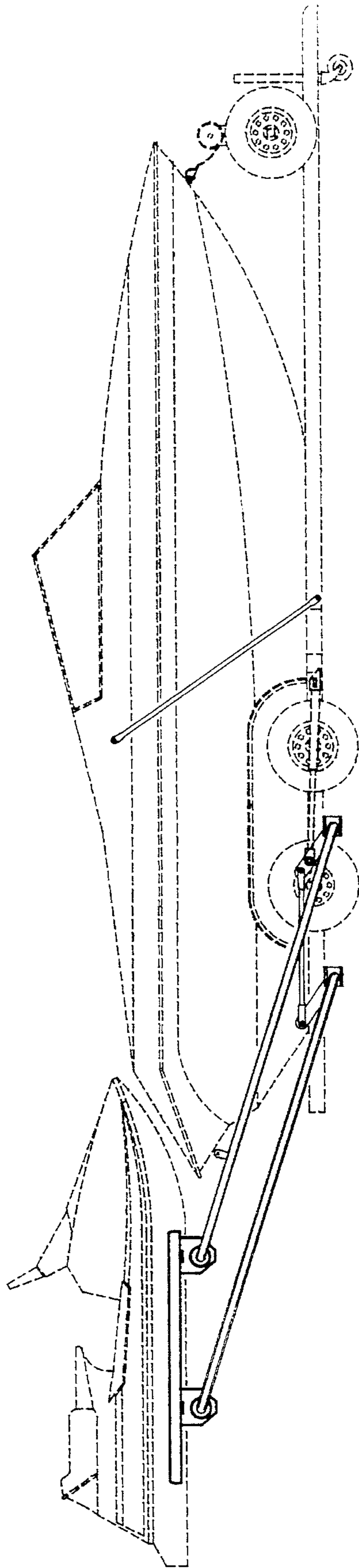

FIG. 8