



US00D366430S

United States Patent [19]
Grundl

[11] **Patent Number: Des. 366,430**

[45] **Date of Patent: **Jan. 23, 1996**

[54] **PRESS BRAKE GAUGE**

5,353,516 10/1994 Dalton 33/833 X

[76] Inventor: **John J. Grundl**, 2341 Eastgate Pl.,
Glendale, Calif. 91208

Primary Examiner—Antoine Duval Davis
Attorney, Agent, or Firm—Wagner & Middlebrook

[**] Term: **14 Years**

[57] **CLAIM**

[21] Appl. No.: **32,066**

The ornamental design for a press brake gauge, as shown
and described.

[22] Filed: **Dec. 13, 1994**

DESCRIPTION

[52] U.S. Cl. **D10/65**

[58] **Field of Search** D8/71, 72; D10/65;
D15/140; 33/520, 627, 655, 833, 838; 72/36,
389, 446, 447, 453.08, 453.13, 461, 472,
473, 481; 100/258 A; 248/225; 355/53

FIG. 1 is a perspective view of a press brake gauge showing
my new design;

FIG. 2 is a right side elevational view thereof;

FIG. 3 is a left end elevational view thereof;

FIG. 4 is a right end elevational view thereof;

FIG. 5 is a top plan view thereof;

FIG. 6 is a left side elevational view thereof; and,

FIG. 7 is a bottom plan view thereof.

[56] **References Cited**

U.S. PATENT DOCUMENTS

4,420,890 12/1983 Naylor 72/36 X
4,494,312 1/1985 Roch 72/36 X
4,583,391 4/1986 Stafford 72/461

1 Claim, 2 Drawing Sheets

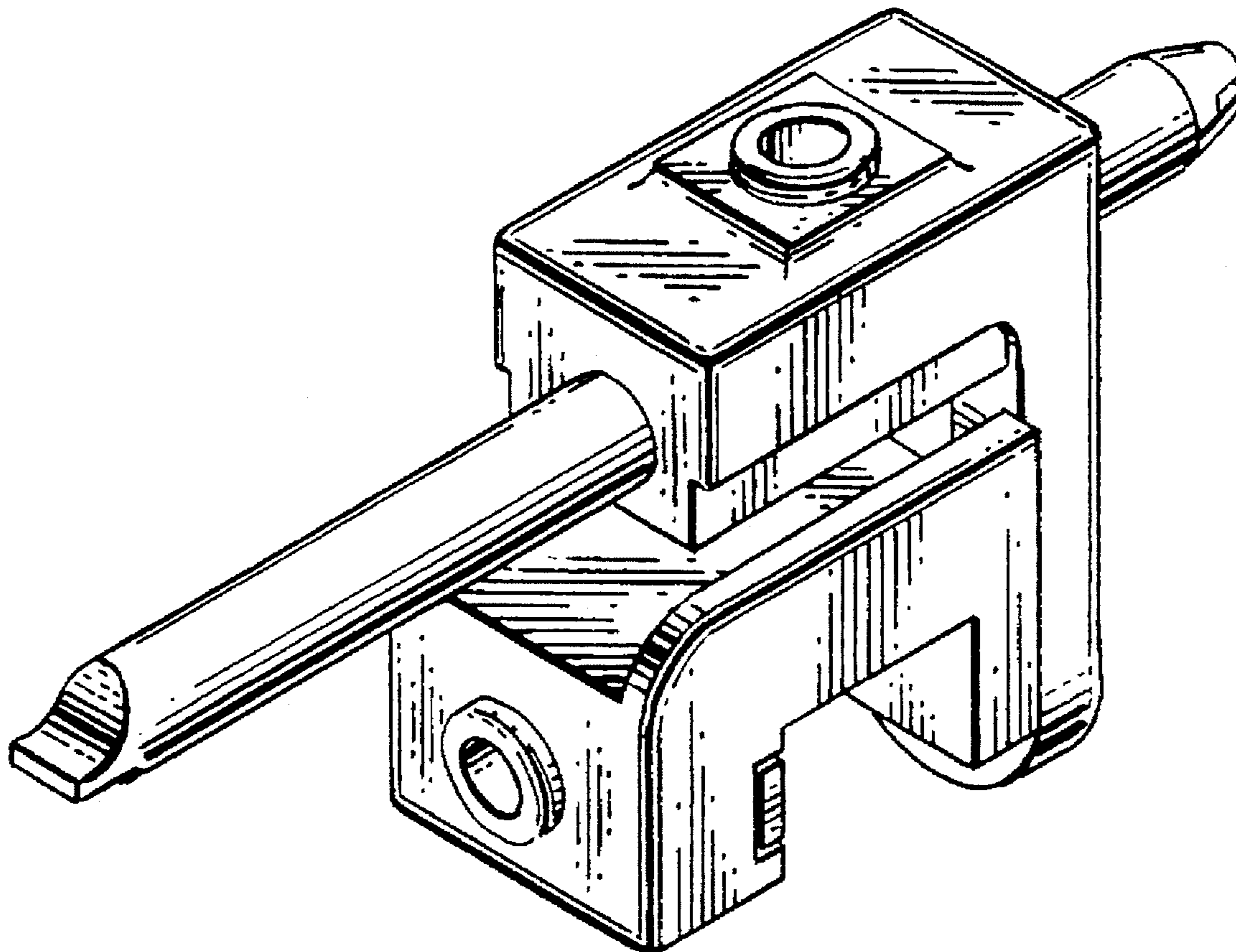

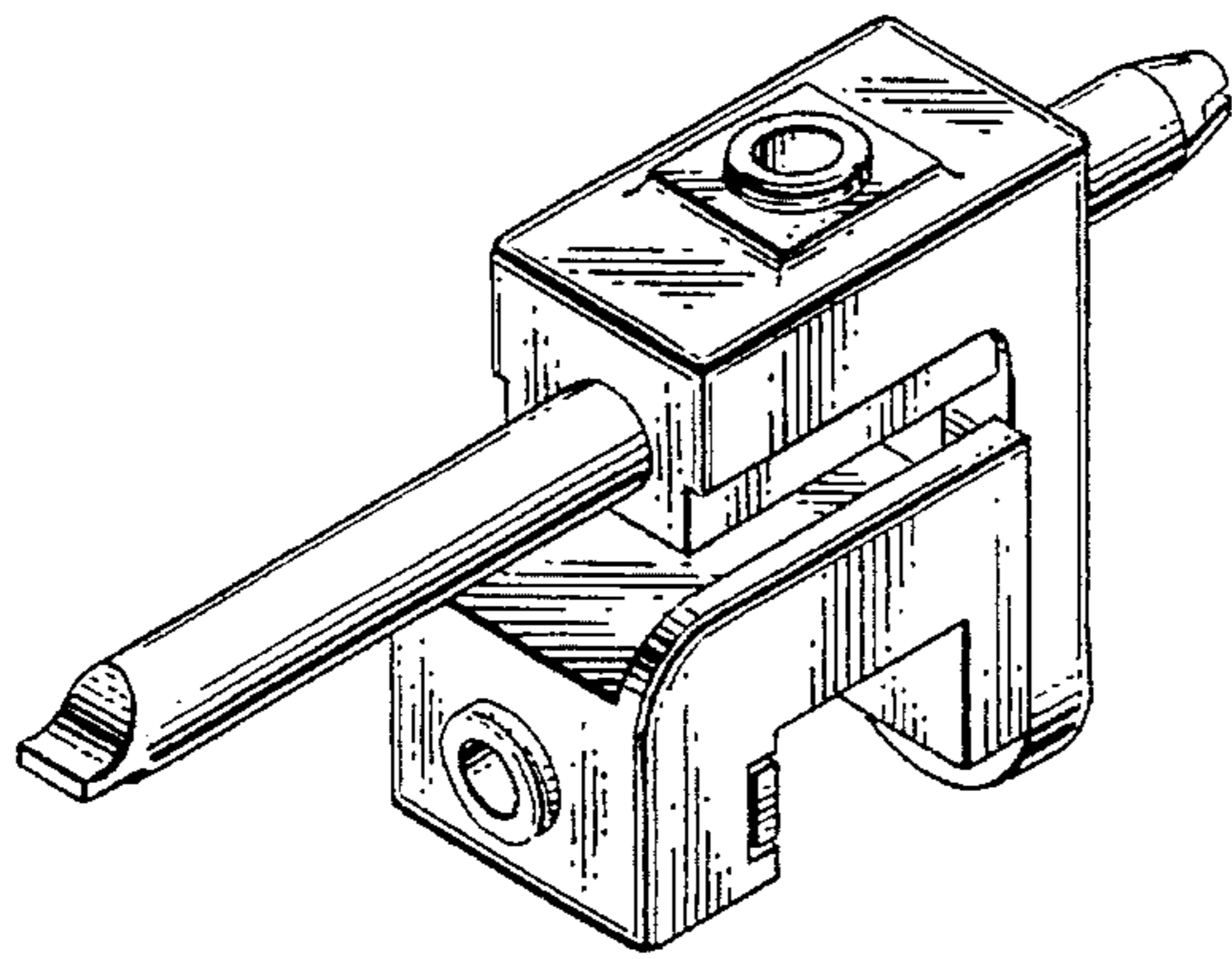

FIG. 1

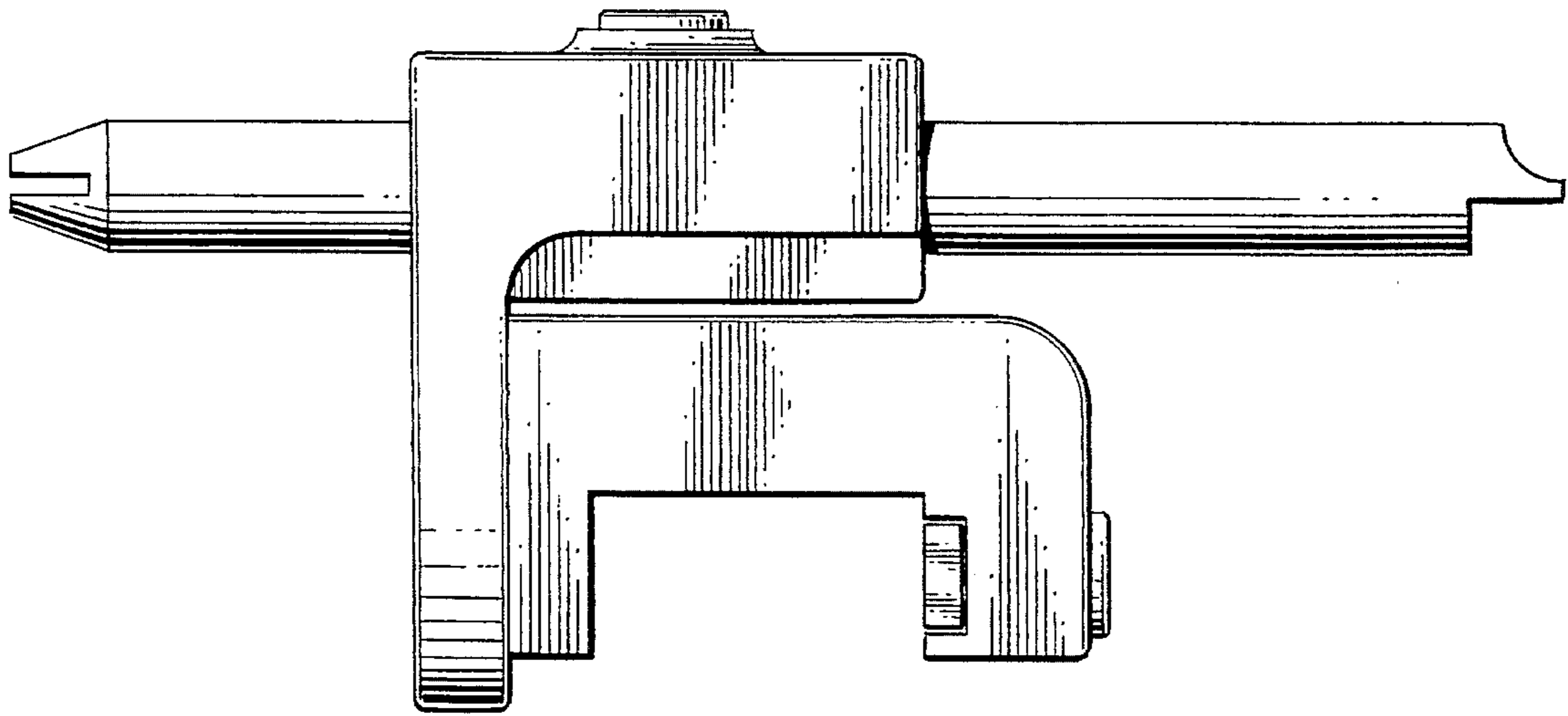

FIG. 2

FIG. 3

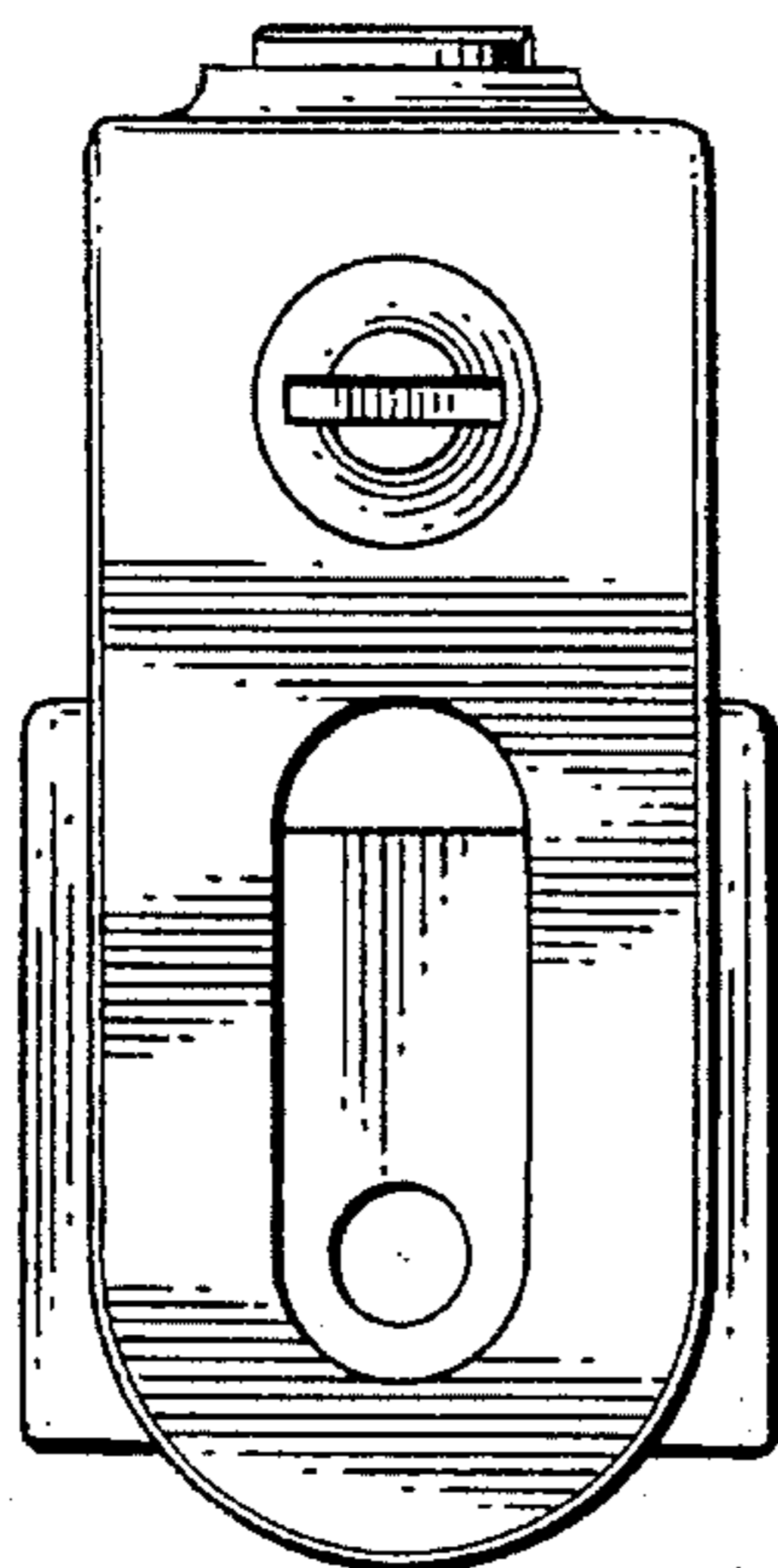

FIG. 4

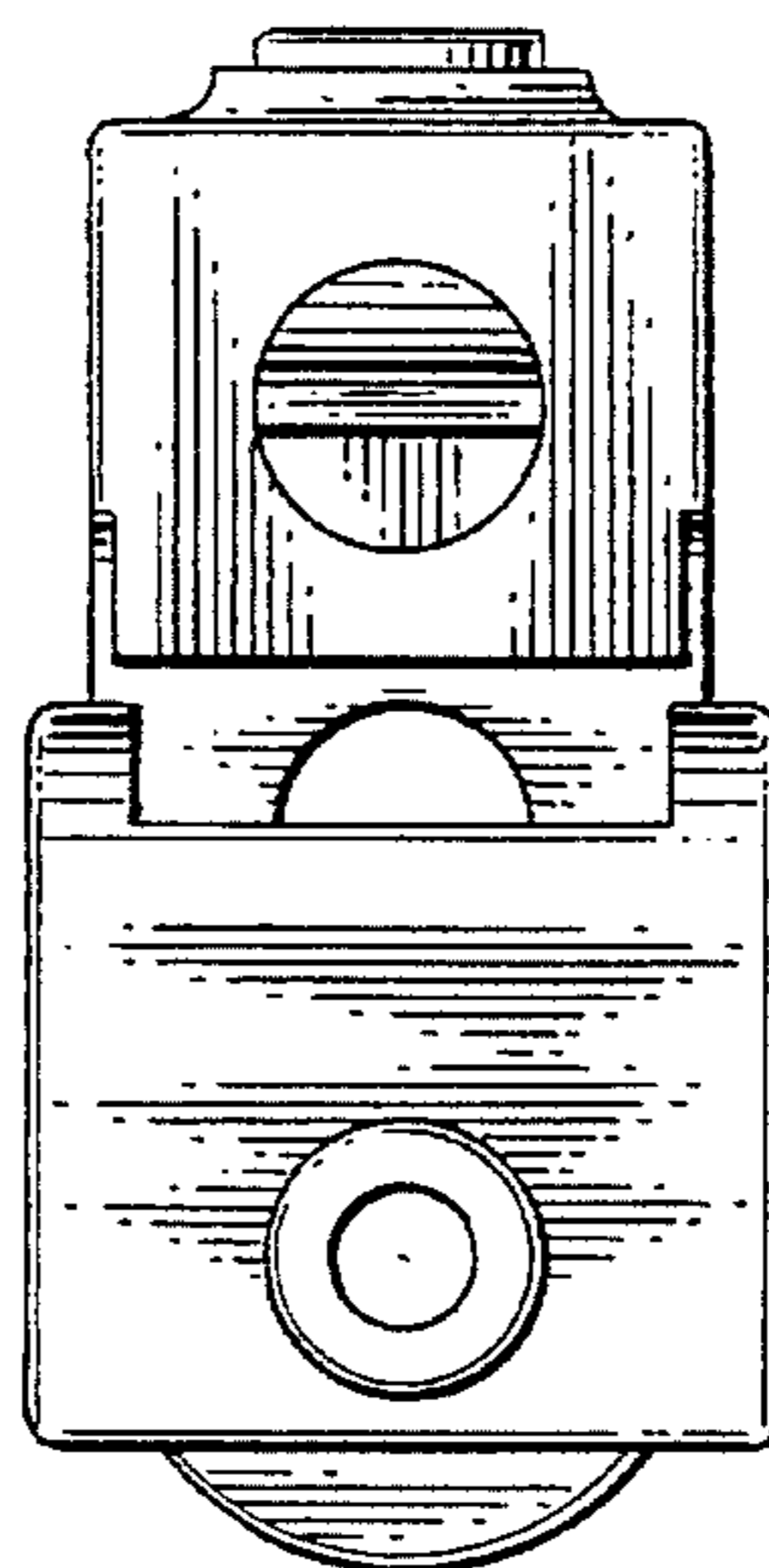

FIG. 5

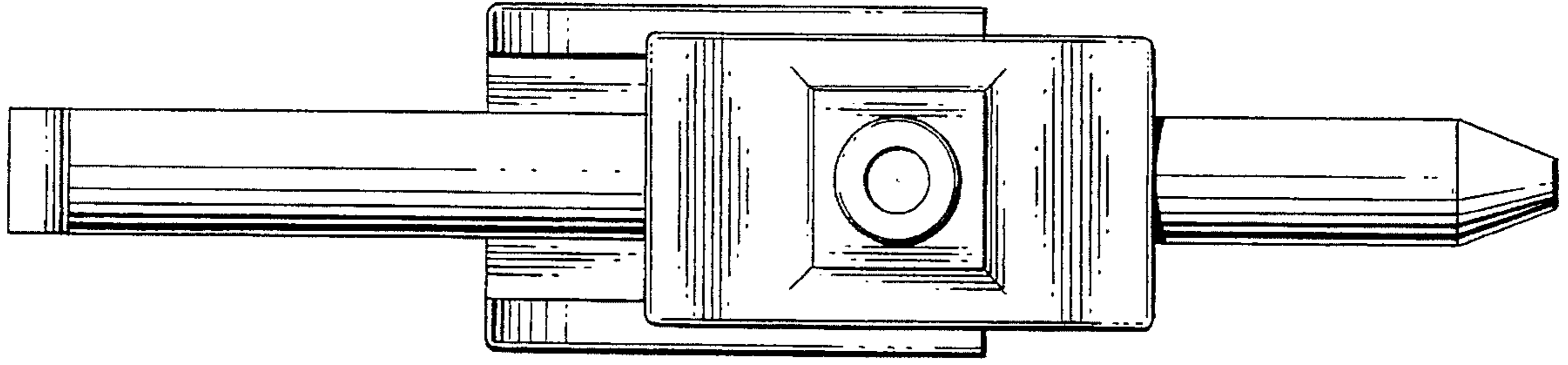

FIG. 6

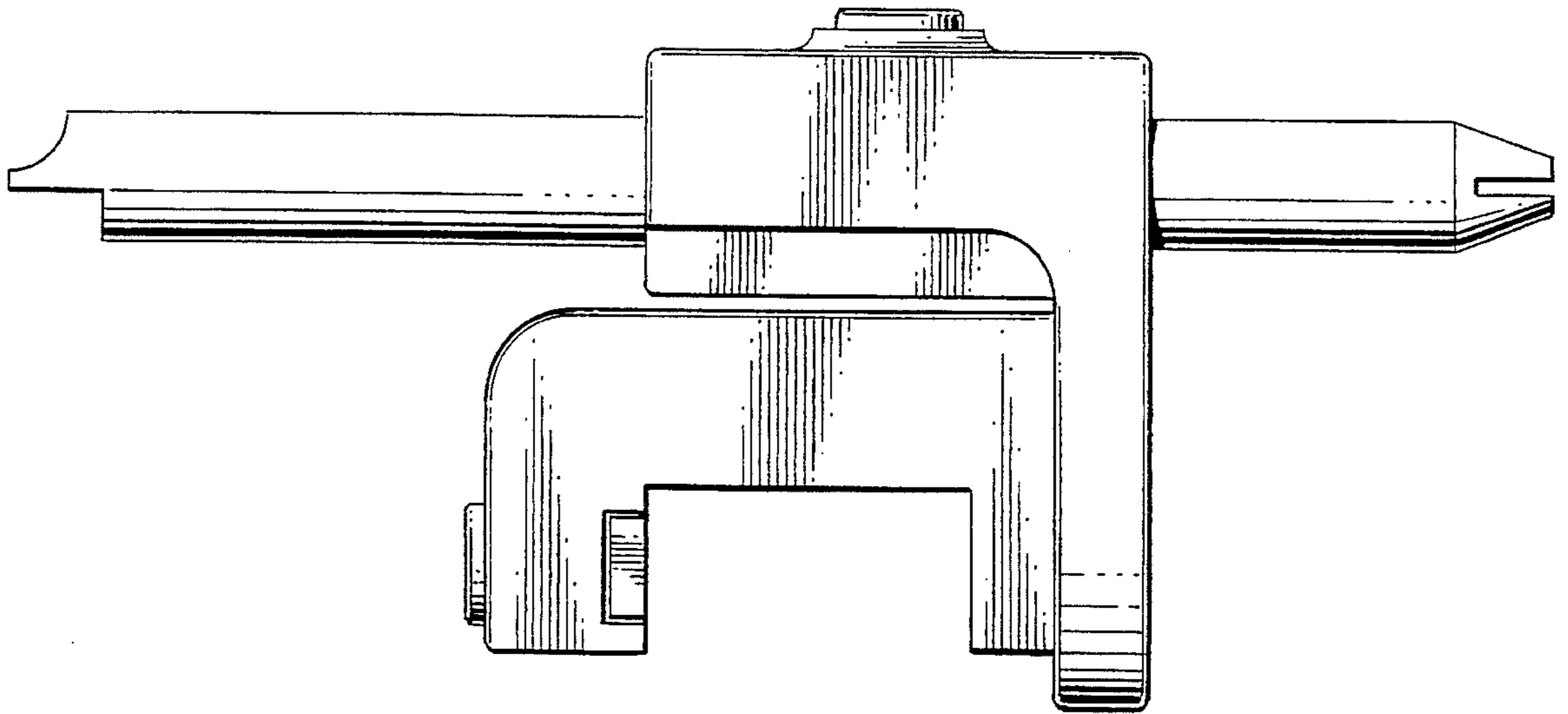

FIG. 7

