



US00D365904S

United States Patent [19]

[11] Patent Number: **Des. 365,904**

Adamson et al.

[45] Date of Patent: ****Jan. 2, 1996**

[54] LUGGAGE CART

[75] Inventors: **Mark Adamson**, Broken Arrow; **Jack W. Hurst**; **James F. Reinbold**, both of Wagoner, all of Okla.

[73] Assignee: **UNR Industries, Inc.**, Chicago, Ill.

[**] Term: **14 Years**

[21] Appl. No.: **33,889**

[22] Filed: **Jan. 23, 1995**

[52] U.S. Cl. **D34/17**; D34/12

[58] Field of Search ... D34/12-27; 280/33.991-33.997, 280/47.35

[56] References Cited

U.S. PATENT DOCUMENTS

2,764,419	9/1956	Enders	280/33.997
2,958,537	11/1960	Young	280/33.991
3,497,234	2/1970	Schray	280/33.993
3,894,748	7/1975	Ratcliff	D34/21
5,149,114	9/1992	Lewandowski et al.	280/33.992

FOREIGN PATENT DOCUMENTS

267817	5/1988	European Pat. Off.	280/33.991
--------	--------	--------------------	-------	------------

Primary Examiner—Kay H. Chin
Attorney, Agent, or Firm—Dressler, Goldsmith, Shore & Milnamow, Ltd.

[57] CLAIM

The ornamental design for a luggage cart, as shown and described.

DESCRIPTION

FIG. 1 is a perspective view of a luggage cart, showing our new design;

FIG. 2 is a left side elevational view thereof, the right side elevational view thereof being a mirror image of the left side elevational view thereof;

FIG. 3 is an elevational view thereof, taken along line 3—3 of FIG. 2, in a direction indicated by arrows;

FIG. 4 is an elevational view thereof, taken along line 4—4 of FIG. 2, in a direction indicated by arrows;

FIG. 5 is an elevational view thereof, taken along line 5—5 of FIG. 2, in a direction indicated by arrows; and,

FIG. 6 is an elevational view thereof, taken along line 6—6 of FIG. 2, in a direction indicated by arrows.

1 Claim, 4 Drawing Sheets

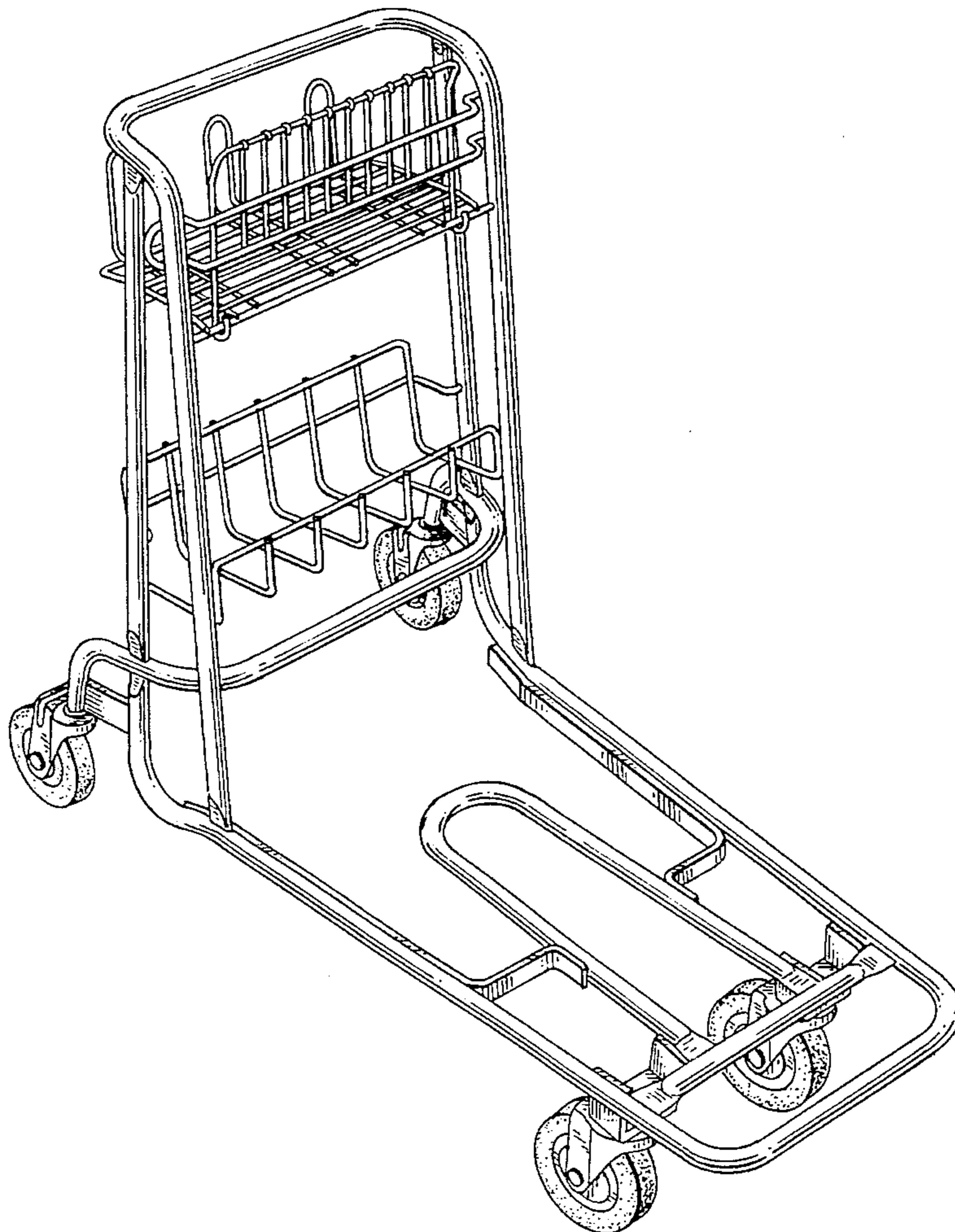

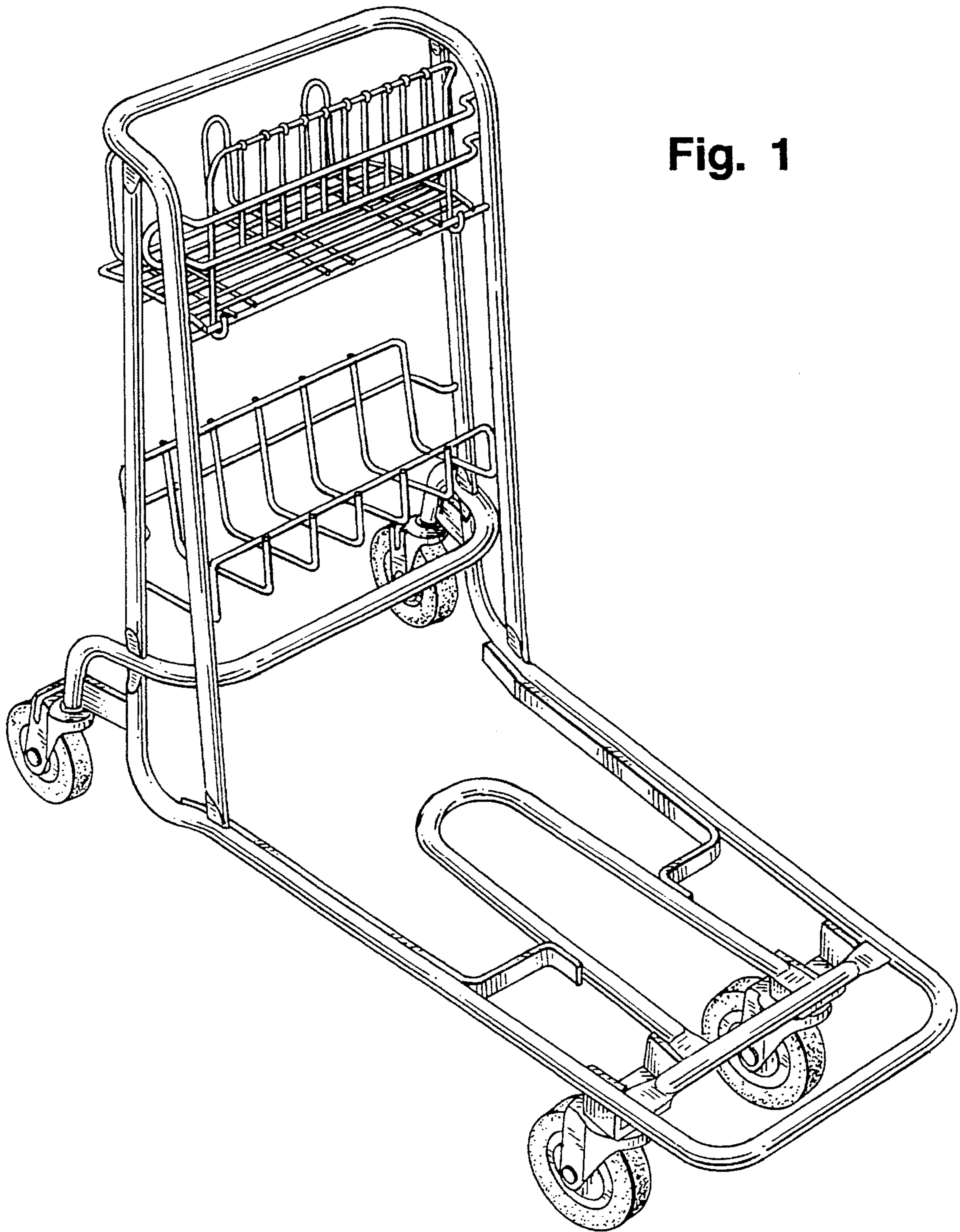

Fig. 1

Fig. 3

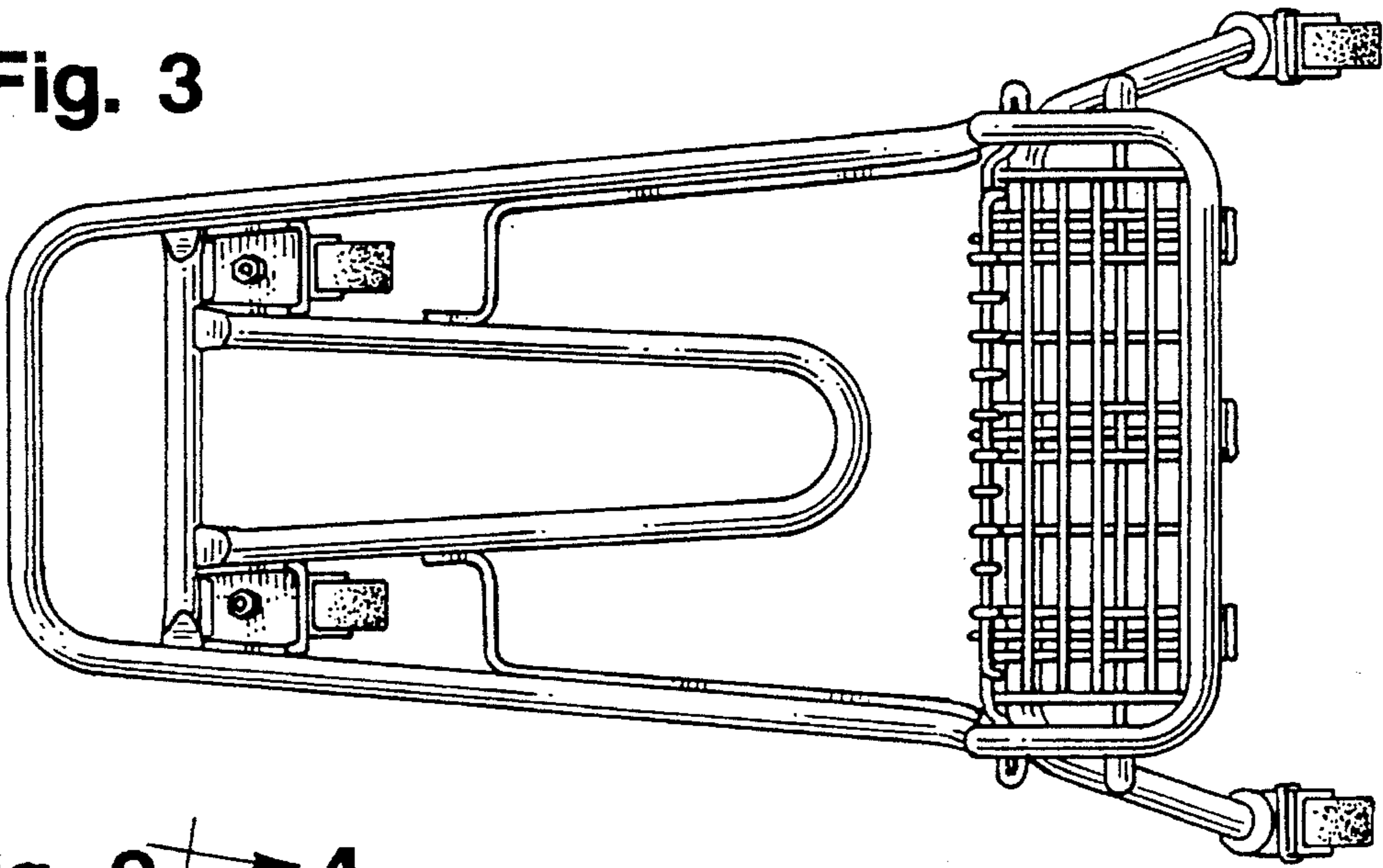

Fig. 2

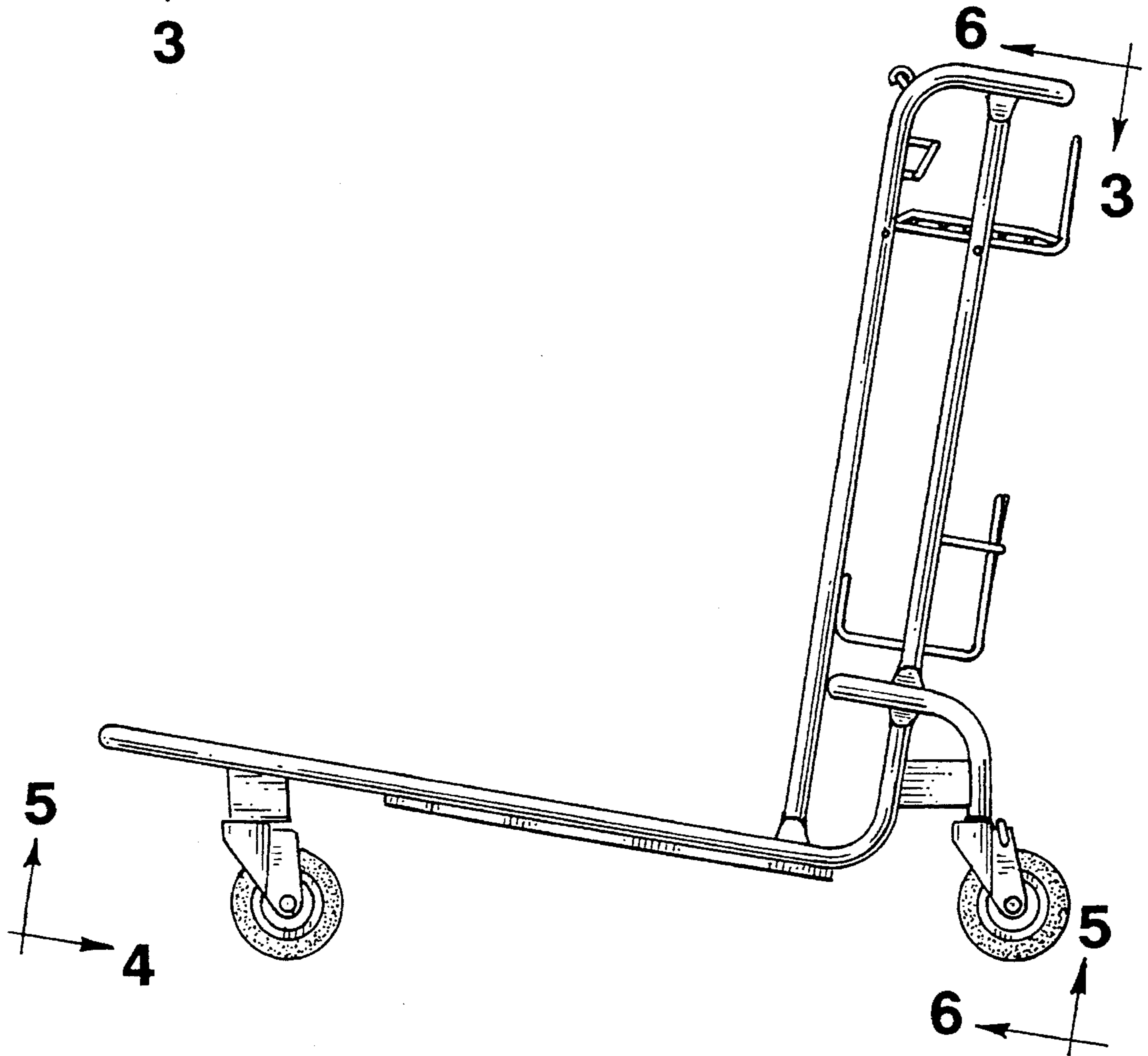

Fig. 4

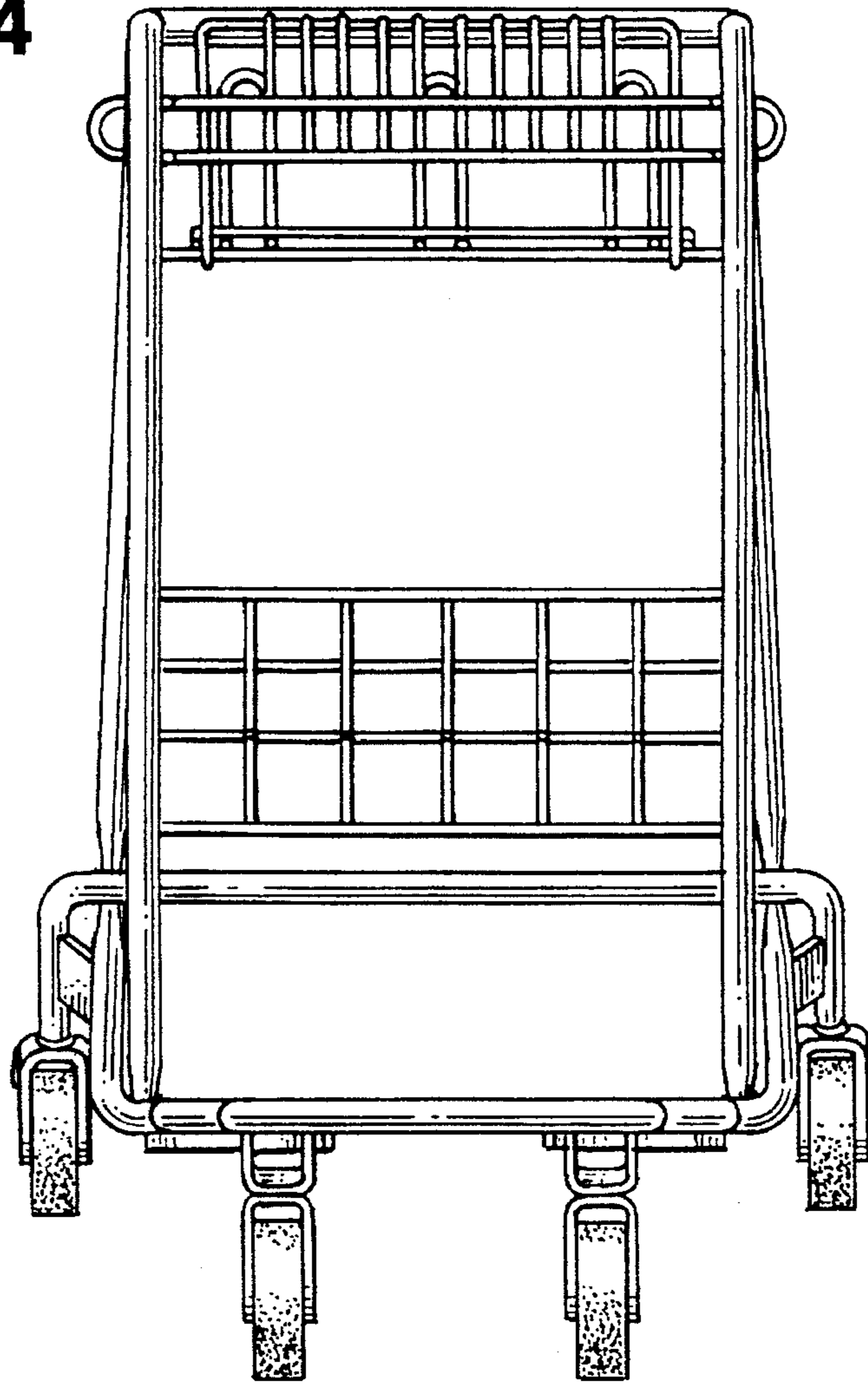

Fig. 5

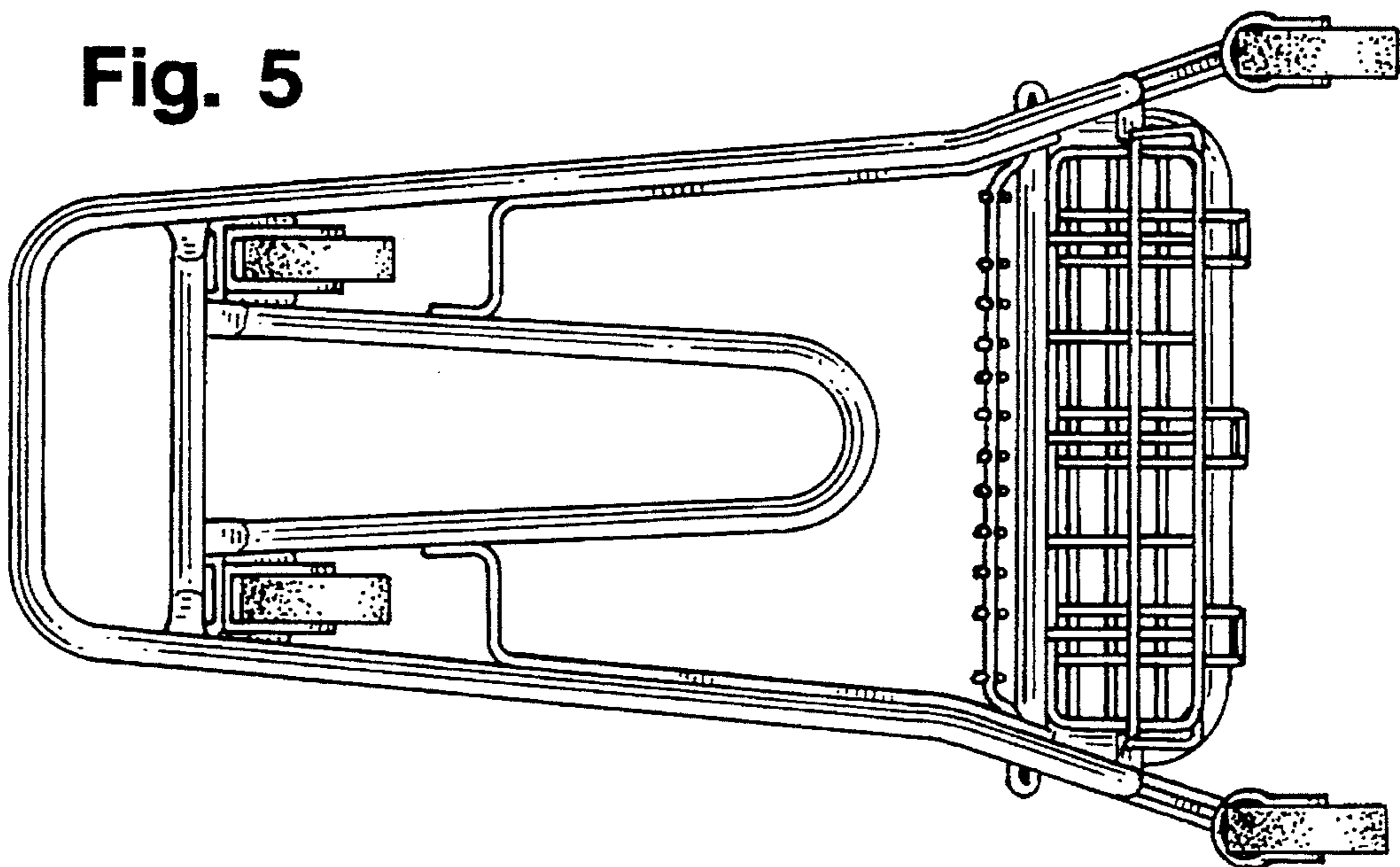

Fig. 6

