



US00D365787S

United States Patent [19]

Peterson et al.

[11] Patent Number: **Des. 365,787**

[45] Date of Patent: ****Jan. 2, 1996**

[54] **SPORT WHEELCHAIR HAVING A T-FRAME**

[75] Inventors: **Christopher J. Peterson; Mary C. Peterson**, both of Teirra Verde, Fla.

[73] Assignee: **Invacare Corporation**, Elyria, Ohio

[**] Term: **14 Years**

[21] Appl. No.: **35,883**

[22] Filed: **Mar. 8, 1995**

4,753,449	6/1988	Doucet .	
4,852,899	8/1989	Kueschall .	
4,887,826	12/1989	Kantner .	
4,927,167	5/1990	Davis .	
5,028,064	7/1991	Johnson .	
5,116,067	5/1992	Johnson .	
5,217,239	6/1993	Koet .	
5,242,180	9/1993	Bergeron .	
5,267,745	12/1993	Robertson et al. .	
5,326,120	7/1994	Weege .	
5,333,894	8/1994	Mayes	280/250.1
5,338,048	8/1994	Medina .	

Related U.S. Application Data

[63] Continuation of Ser. No. 14,031, Oct. 12, 1993, abandoned, which is a continuation of Ser. No. 135,745, Oct. 12, 1993.

[52] U.S. Cl. **D12/131**

[58] Field of Search D12/128, 131; 280/250.1, 647, 242.1; 297/DIG. 4

References Cited

U.S. PATENT DOCUMENTS

D. 217,679	12/1983	Minnebraker .	
D. 278,217	4/1985	Nassiri	D12/131
D. 294,475	3/1988	Chen	D12/131
D. 306,712	3/1990	Friedrich	D12/131
D. 336,452	6/1993	Holm-Rasmussen .	
D. 342,468	12/1993	Goslett	D12/131
D. 344,702	3/1994	Robertson et al.	D12/131
4,166,631	9/1979	Sanaski .	
4,360,213	11/1982	Rudwick et al. .	
4,523,769	6/1985	Glaser et al. .	
4,650,201	3/1987	Hartwell	280/647
4,652,005	3/1987	Hartwell	280/250.1
4,679,816	7/1987	Riikonen	280/647

FOREIGN PATENT DOCUMENTS

3614726 11/1987 Germany .

Primary Examiner—Kay H. Chin

Attorney, Agent, or Firm—Fay, Sharpe, Beall, Fagan, Minnich & McKee

[57] CLAIM

The ornamental design for a sport wheelchair having a T-frame, as shown.

DESCRIPTION

FIG. 1 is a front perspective view of a sport wheelchair having a T-frame showing our new design;
 FIG. 2 is a front elevational view thereof;
 FIG. 3 is a left side elevational view thereof;
 FIG. 4 is a right side elevational view thereof;
 FIG. 5 is a rear elevational view thereof;
 FIG. 6 is a top plan view thereof; and,
 FIG. 7 is a bottom plan view thereof.

1 Claim, 4 Drawing Sheets

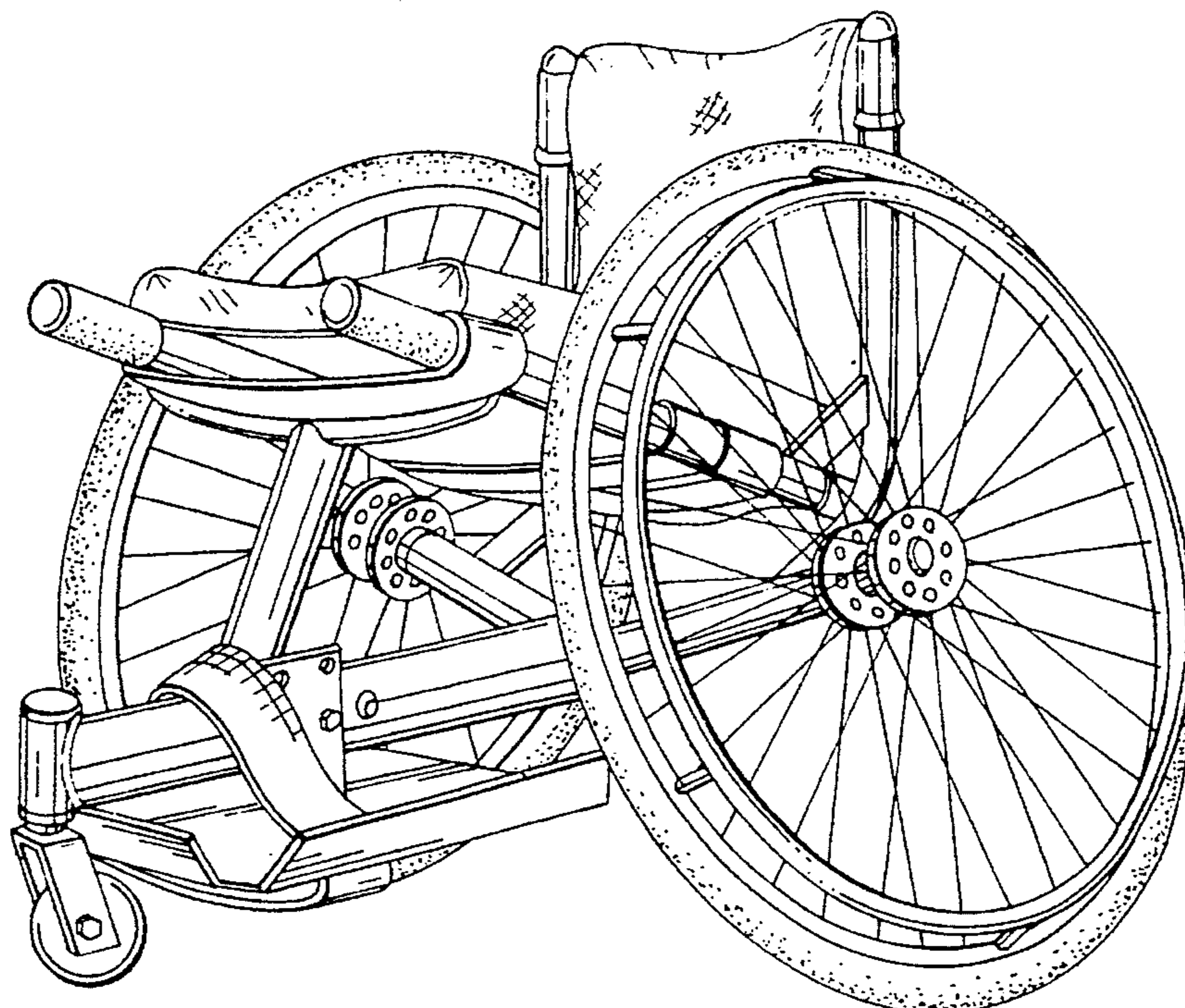

Fig. 1

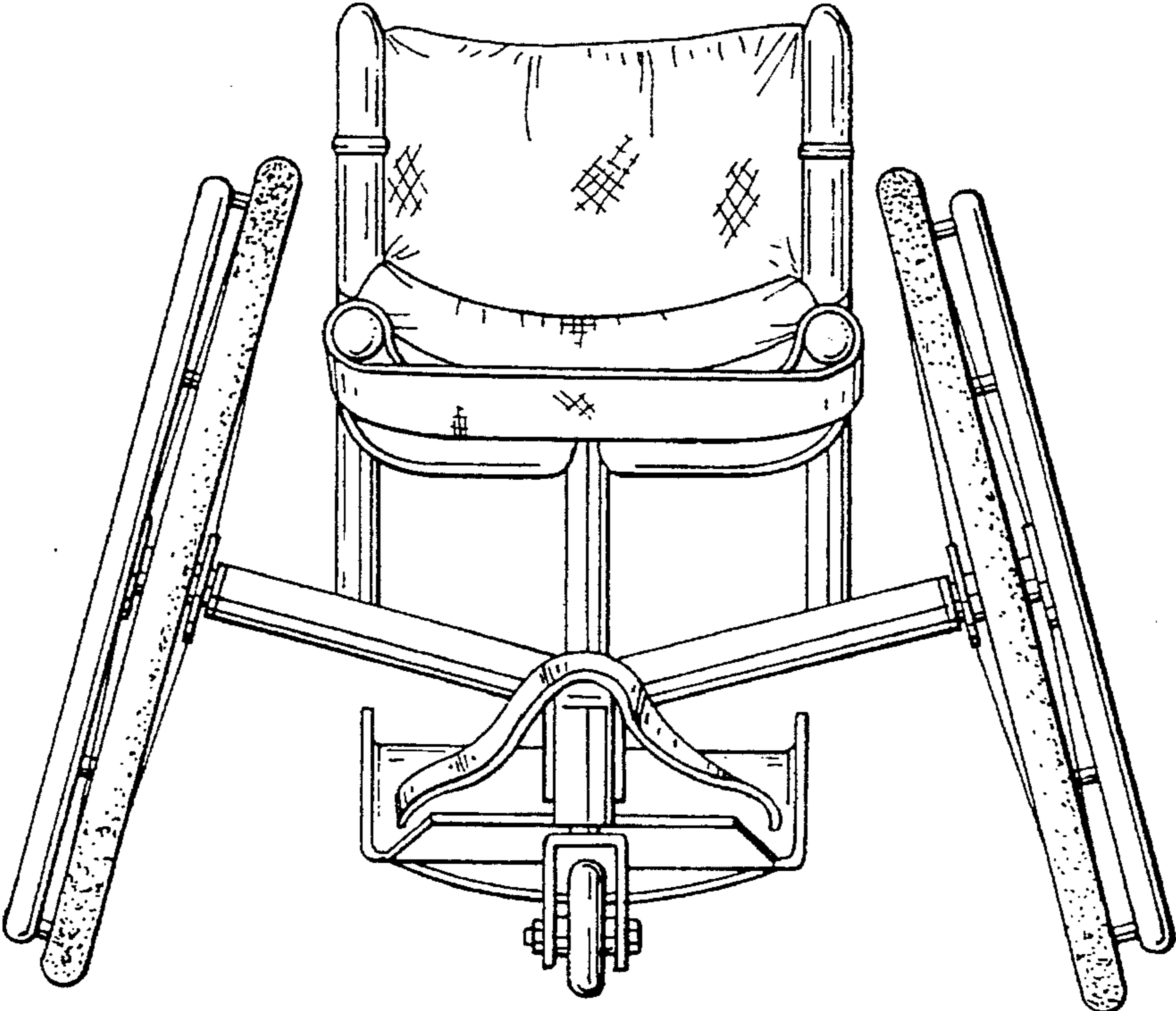
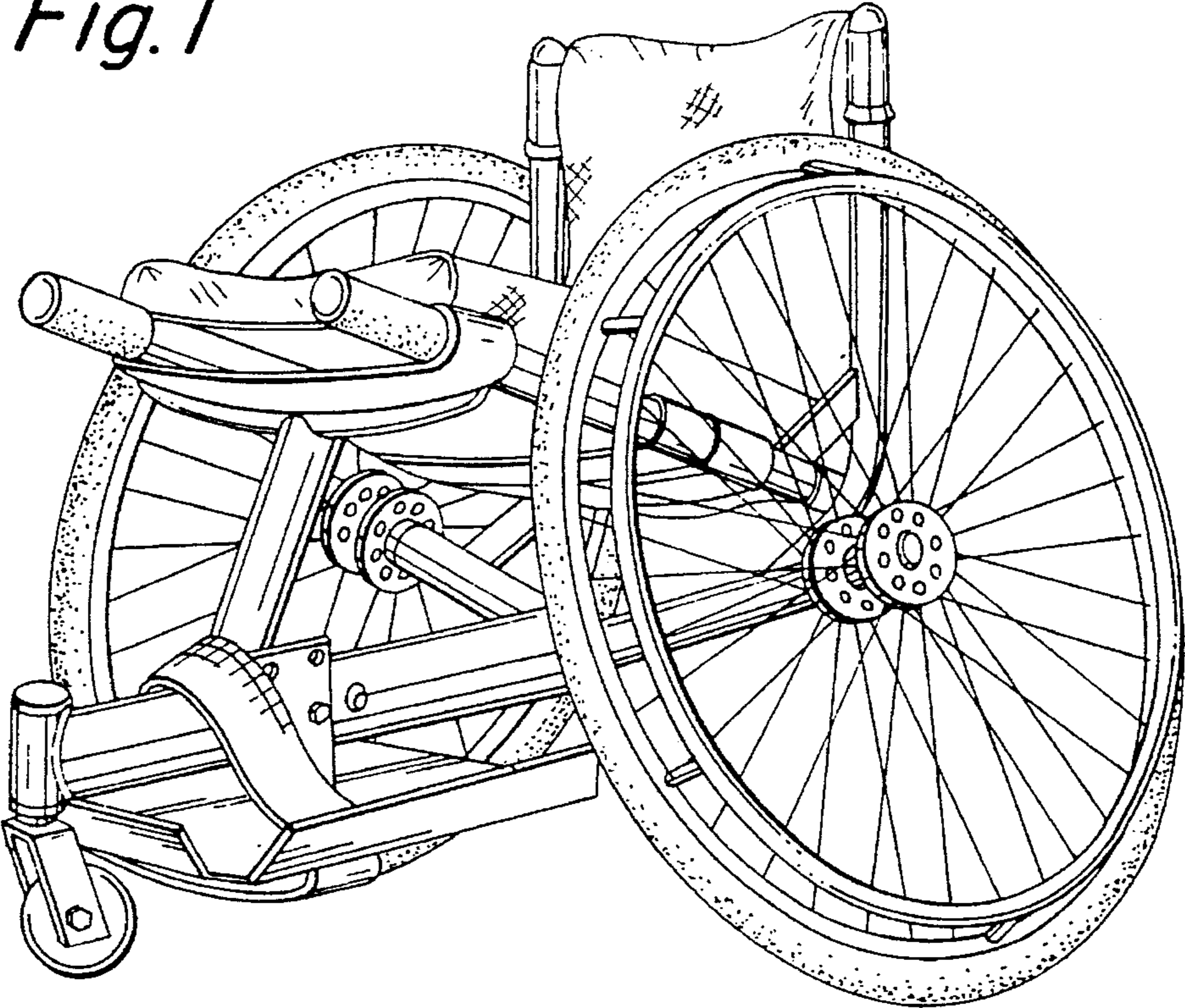

Fig. 2

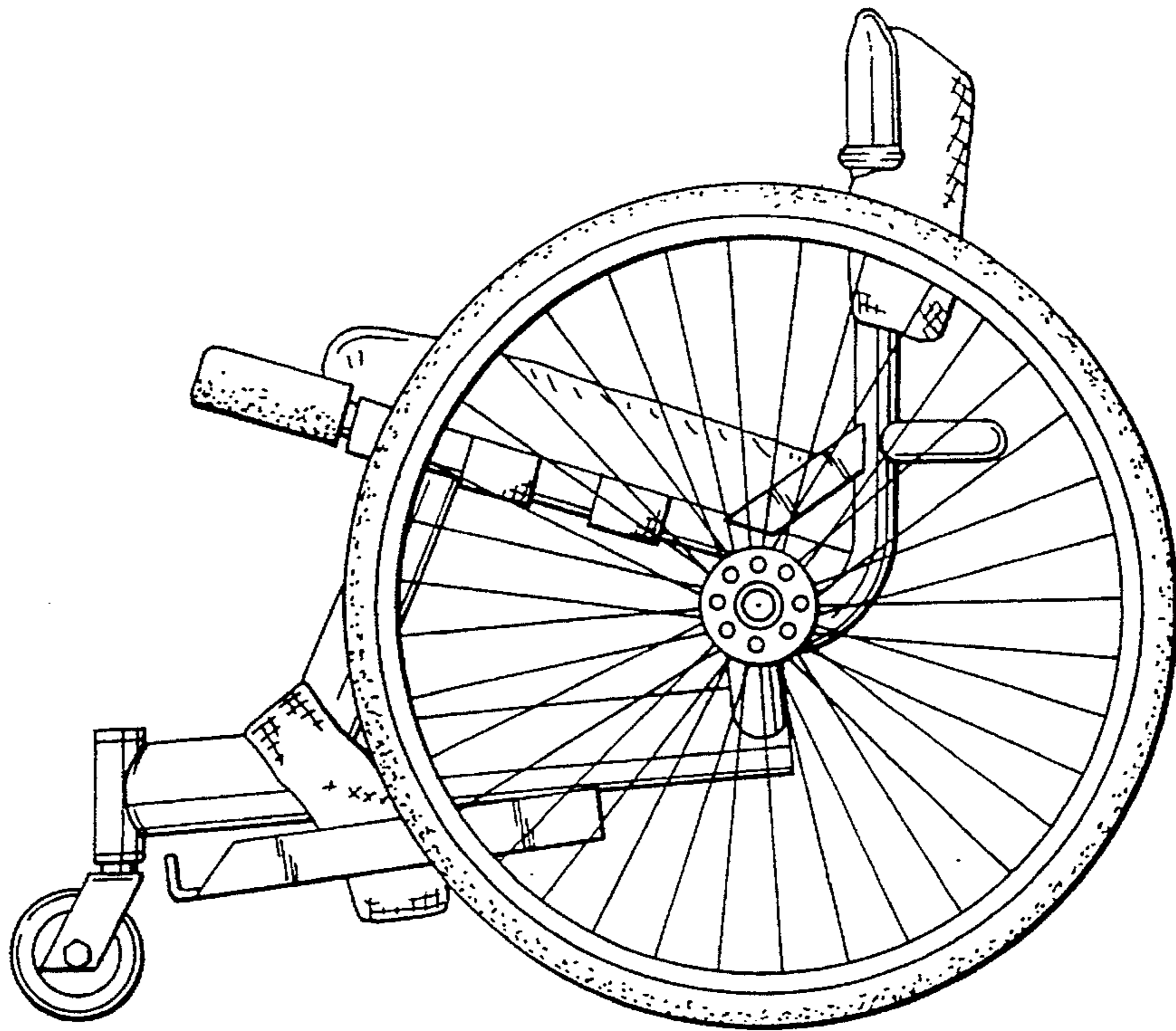

Fig. 3

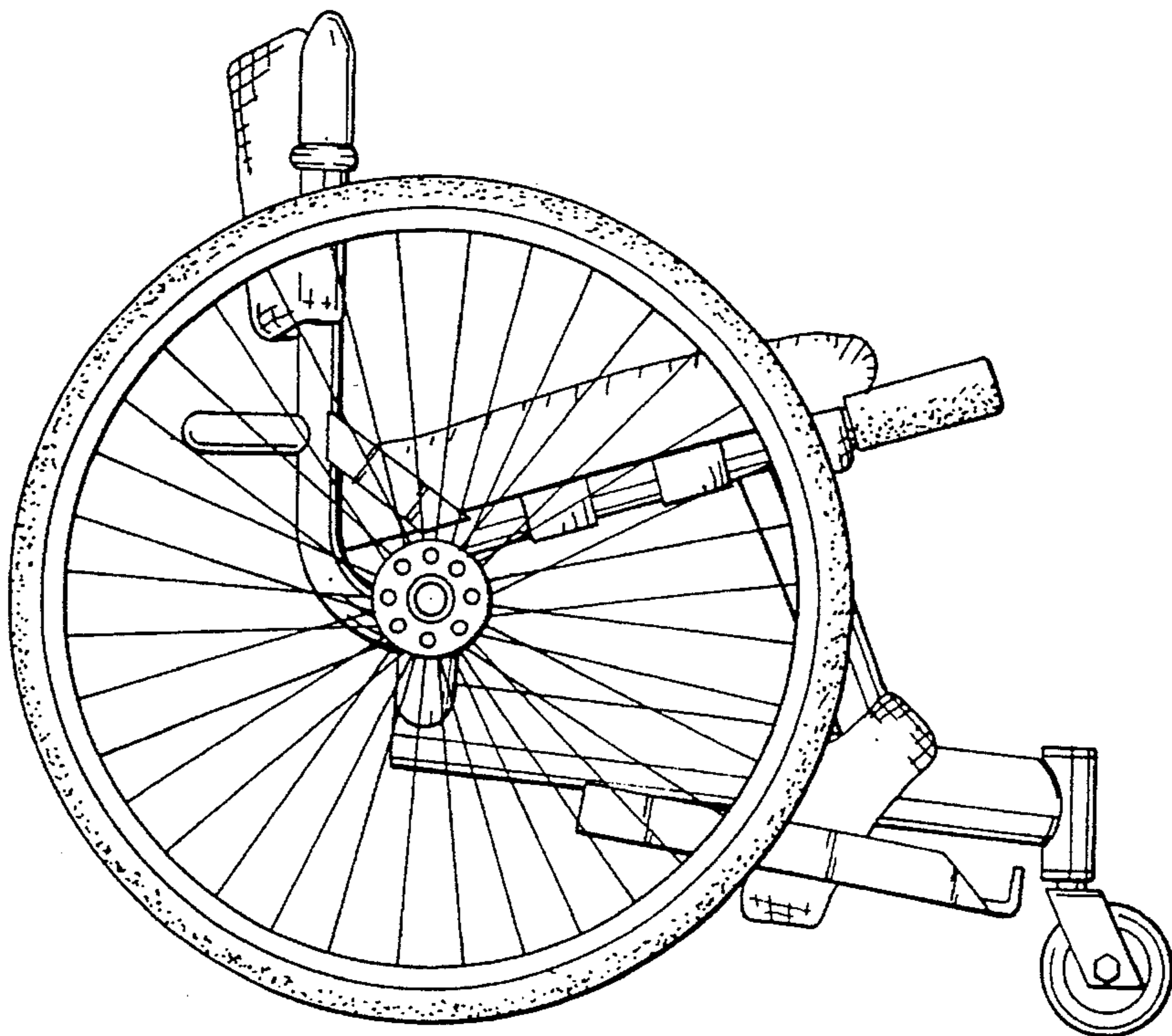

Fig. 4

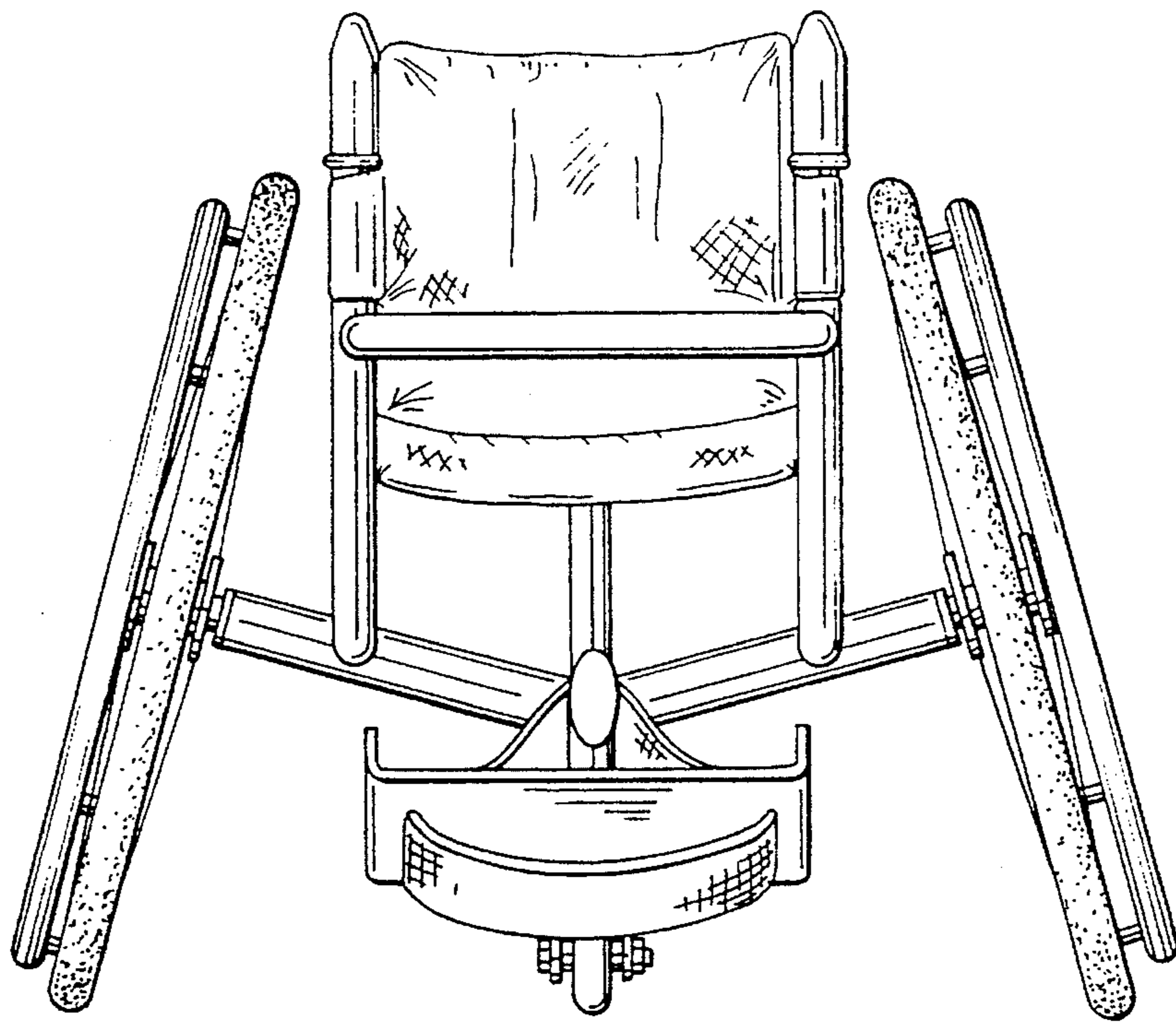

Fig. 5

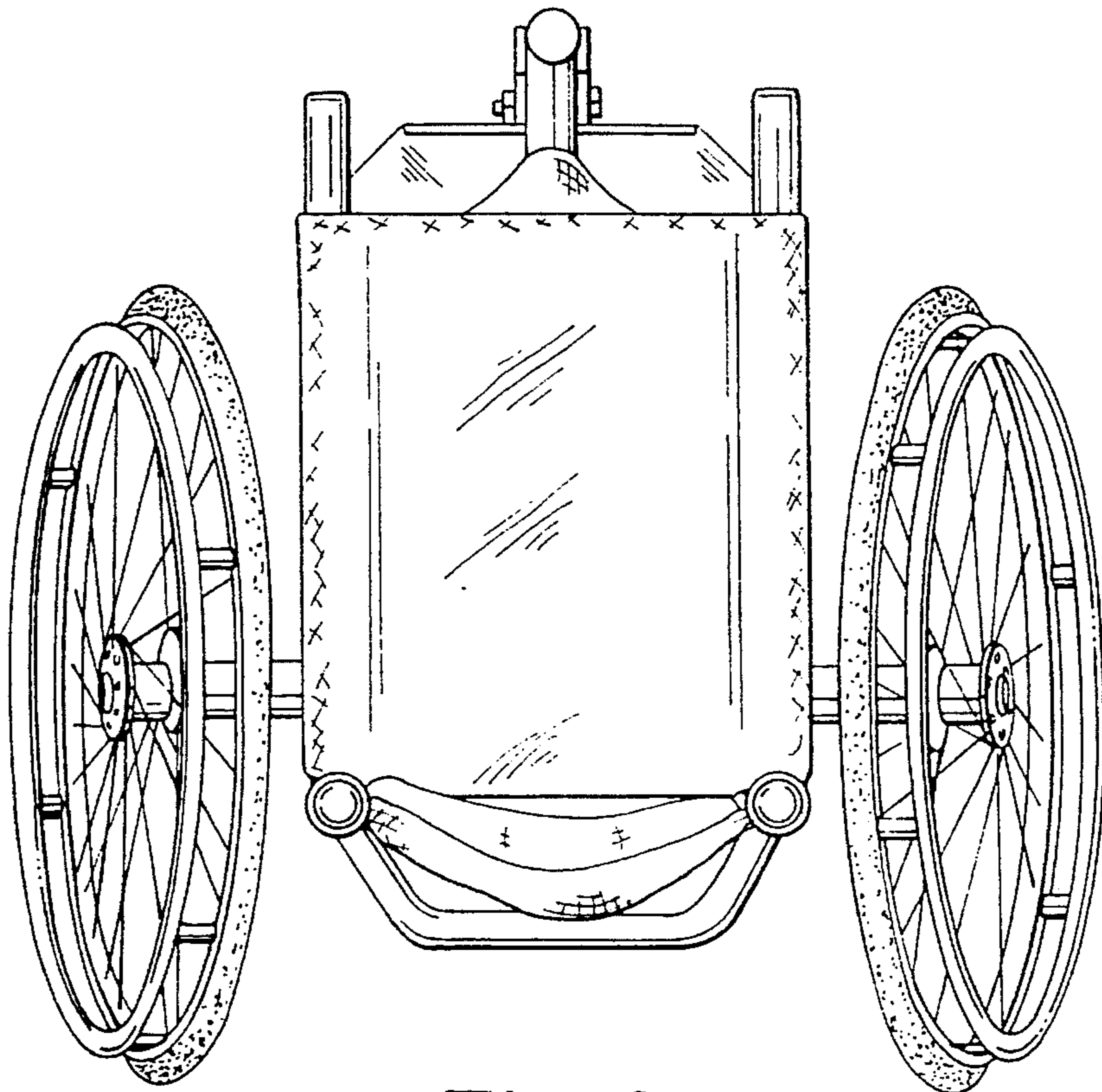

Fig. 6

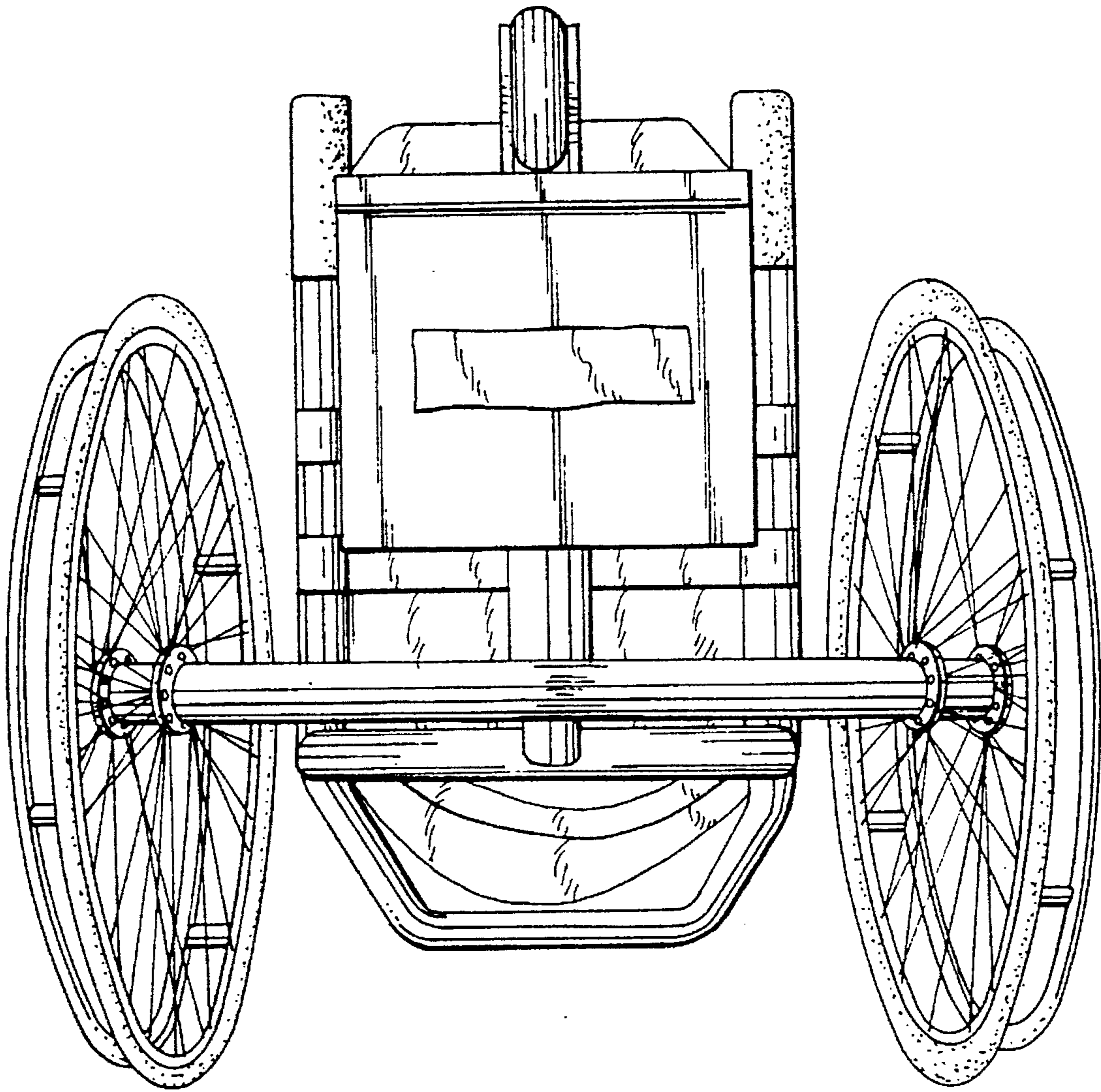

Fig. 7