



US00D365072S

# United States Patent [19]

Vallance

[11] Patent Number: **Des. 365,072**

[45] Date of Patent: **\*\*Dec. 12, 1995**

## [54] COMBINED TRAILER HITCH AND GUIDE

[76] Inventor: **Gordon E. Vallance**, 64 Jensen Crescent, Airdrie, Alberta, Canada, T4B 1P1

[\*\*] Term: **14 Years**

[21] Appl. No.: **18,309**

[22] Filed: **Feb. 3, 1994**

[52] U.S. Cl. .... **D12/162**

[58] Field of Search ..... D12/162; 280/477, 280/507; 33/264; 116/28.1

### [56] References Cited

#### U.S. PATENT DOCUMENTS

D. 338,644	8/1993	Wenton	.....	D12/162
D. 343,153	1/1994	Erickson et al.	.....	D12/162
D. 349,084	7/1994	Huffman et al.	.....	D12/162
4,054,302	10/1977	Campbell	.....	280/477
4,065,147	12/1977	Ross	.....	280/477
4,583,481	4/1986	Garrison	.....	280/477

#### OTHER PUBLICATIONS

"Help When Hooking Up"—Camping Canada Magazine vol. 21 No. 4.

*Primary Examiner*—A. Hugo Word

*Assistant Examiner*—M. Brown

*Attorney, Agent, or Firm*—Terry M. Gernstein

### [57] CLAIM

The ornamental design for a combined trailer hitch and guide, as shown and described.

### DESCRIPTION

FIG. 1 is a front, top and side perspective view of the combined trailer hitch and guide showing my new design;

FIG. 2 is a front elevational view thereof, the rear being a mirror image of the front shown in FIG. 2;

FIG. 3 is an end elevational view thereof;

FIG. 4 is an elevational view thereof opposite to the end shown in FIG. 3;

FIG. 5 is a top plan view thereof; and,

FIG. 6 is a bottom plan view thereof.

The portion of the guide shown broken away in FIGS. 1, 2, 5 and 6 is to indicate indeterminate length.

1 Claim, 3 Drawing Sheets

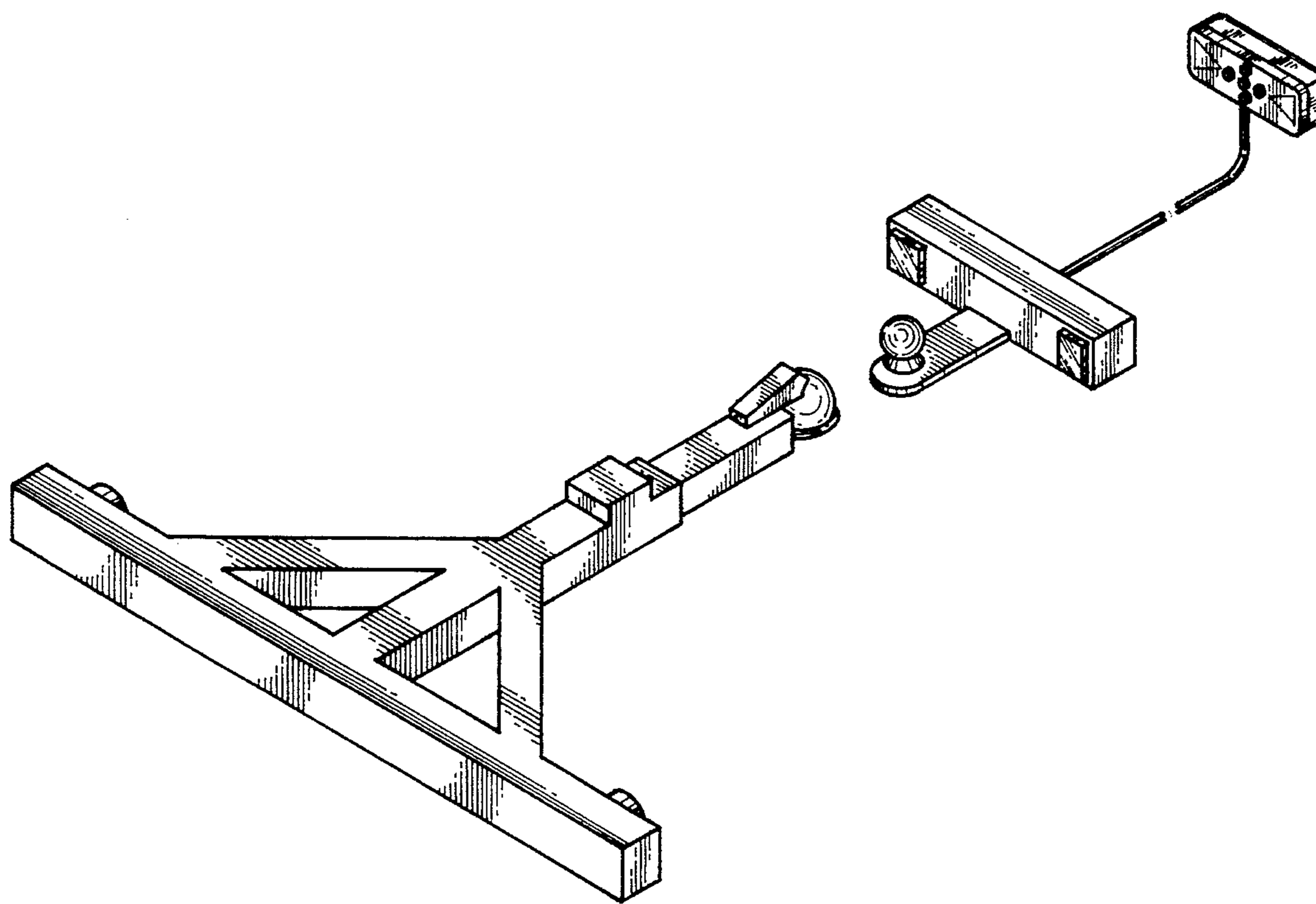

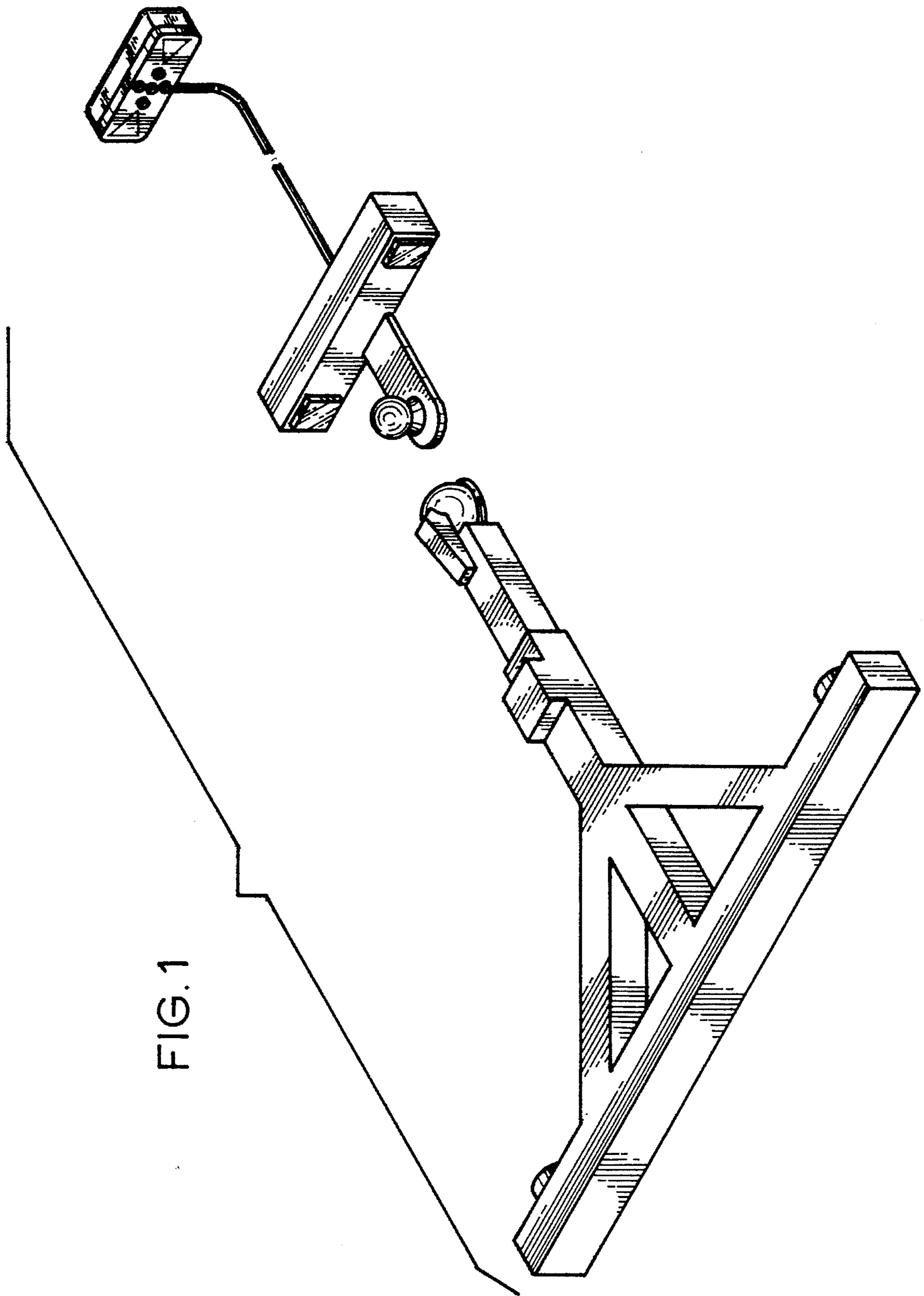

FIG. 1

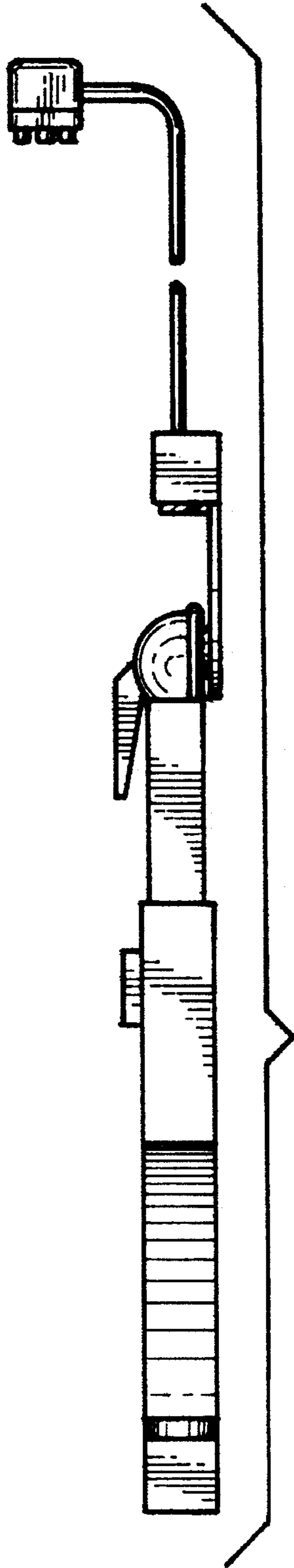

FIG. 2

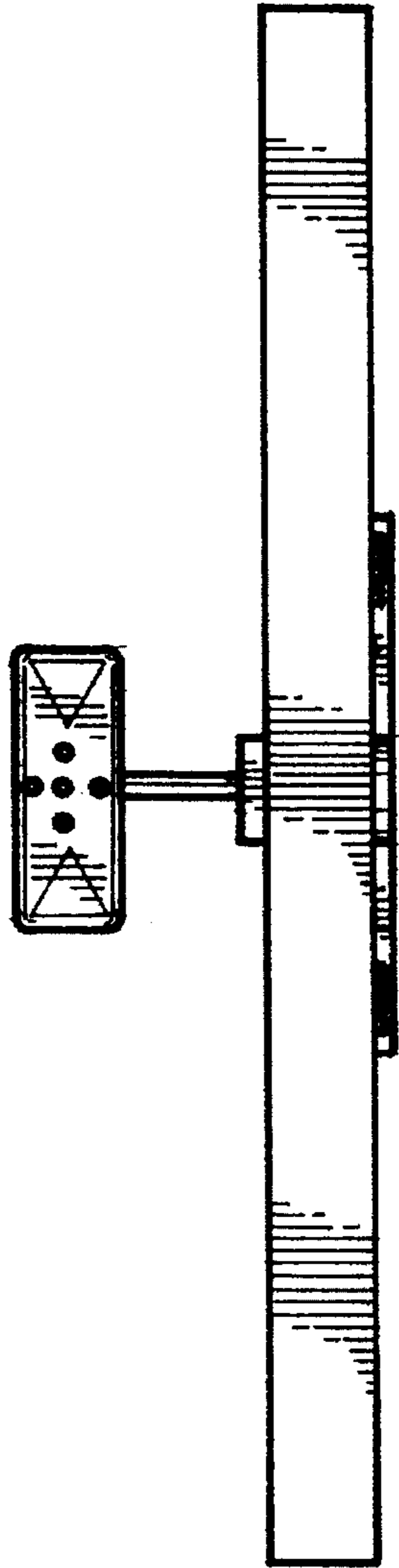

FIG. 3

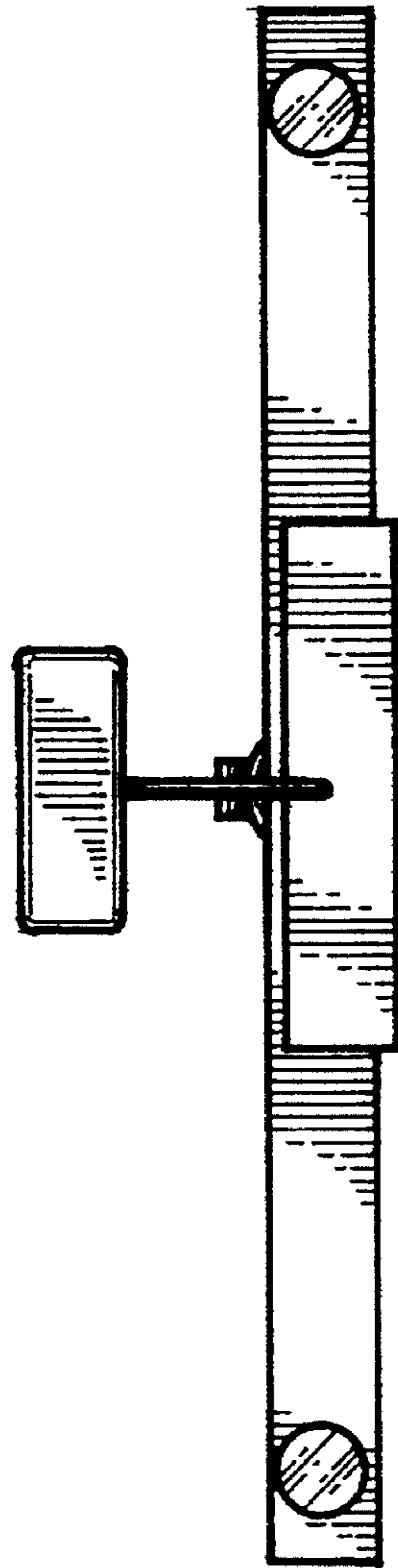

FIG. 4

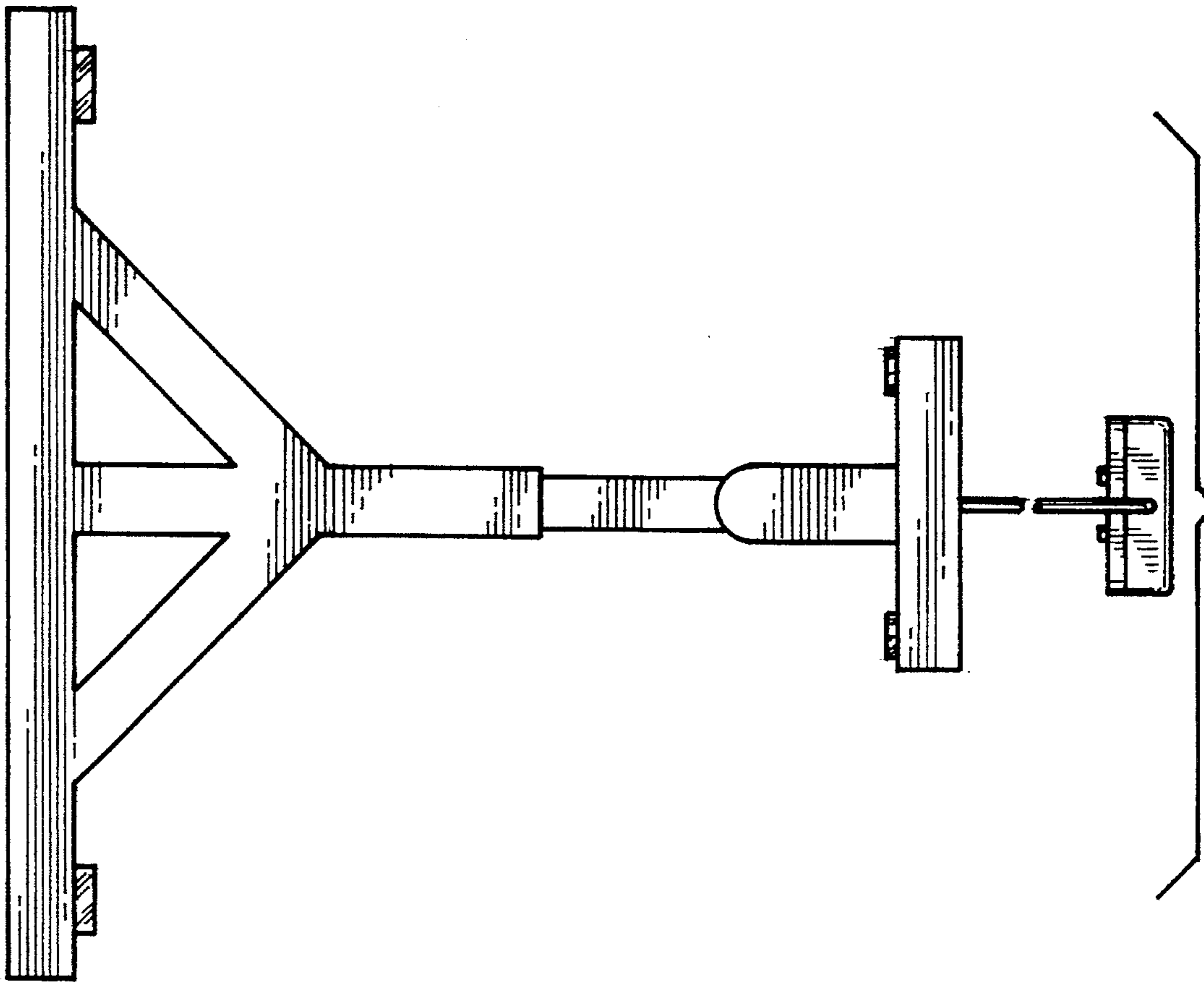

FIG. 6

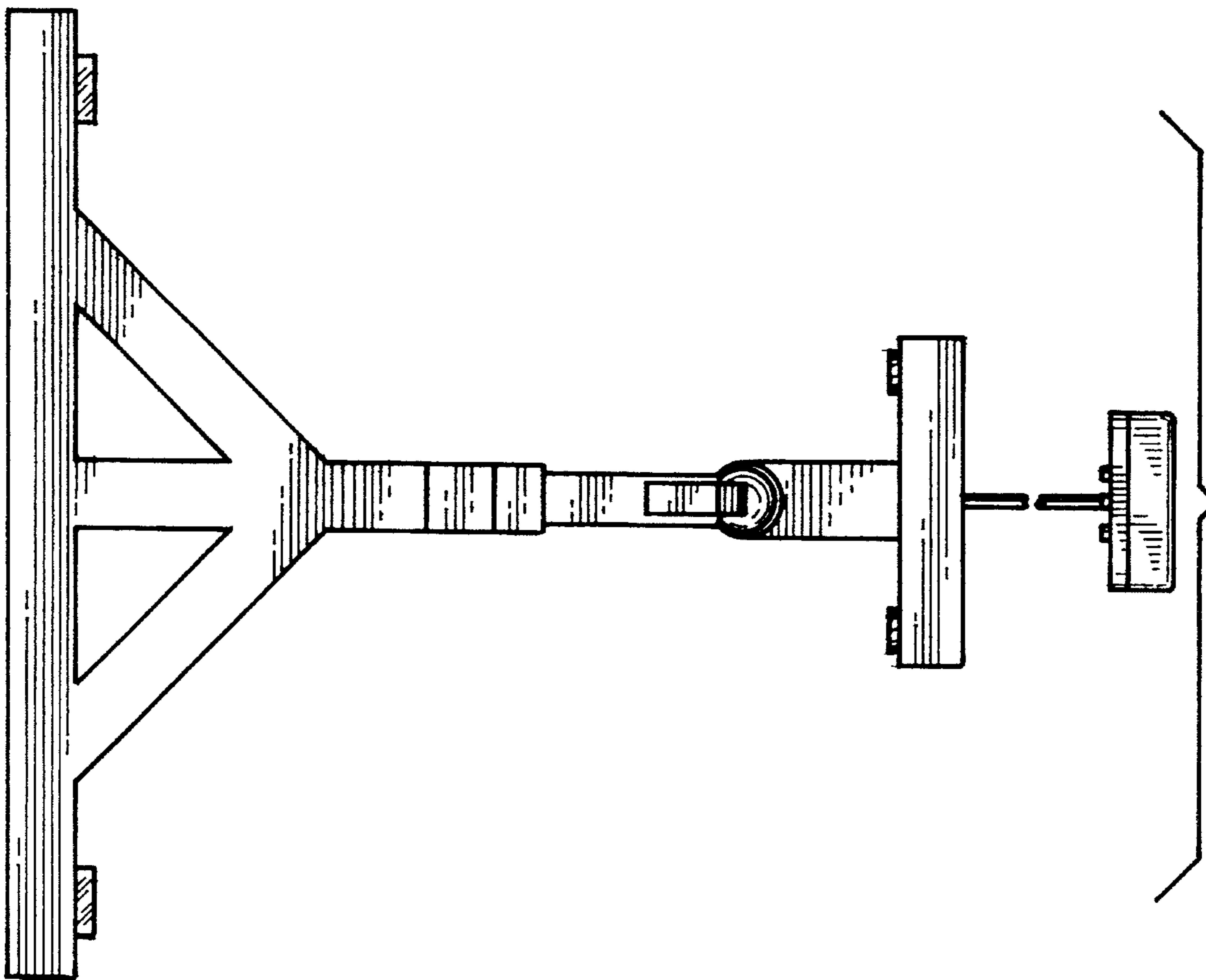

FIG. 5