



US00D364946S

United States Patent [19] Stenovich

[11] Patent Number: **Des. 364,946**

[45] Date of Patent: ****Dec. 5, 1995**

[54] **EMISSIONS SCRUBBER FOR WOOD BURNING UNITS**

5,311,637	5/1994	Broussard	15/301
5,376,166	12/1994	Hoffmann et al.	261/17
5,405,590	4/1995	Macedo et al.	55/229

[76] Inventor: **Donald A. Stenovich**, 315 Major Way, Henderson, Nev. 89015

[**] Term: **14 Years**

[21] Appl. No.: **11,905**

[22] Filed: **Aug. 18, 1993**

[52] U.S. Cl. **D32/1**

[58] Field of Search D32/1; 55/220, 55/DIG. 30, 229; 15/301, 323, 327 F, 319, 327.1, 327 D; 261/DIG. 9, 17

FOREIGN PATENT DOCUMENTS

147822	8/1952	Australia	15/301
157692	1/1940	Austria	55/229
056980	5/1979	Japan	55/220
7712583	5/1979	Netherlands	261/17
2907	2/1906	United Kingdom	55/229
672970	5/1952	United Kingdom	15/301

OTHER PUBLICATIONS

Turbulaire MX Catalog by Joy Manufacturing Co./Western Precipitation Div.; Cover photograph.

Primary Examiner—Cathy Anne MacCormac
Attorney, Agent, or Firm—Terry M. Gernstein

[56] References Cited

U.S. PATENT DOCUMENTS

1,269,724	6/1918	Martin	261/17
1,471,927	10/1923	Schutt et al.	15/301
2,768,705	10/1956	Isseris	55/229
3,485,671	12/1969	Stephens	15/301
4,276,063	6/1981	Lackey et al.	261/17
4,342,131	8/1982	Reid	15/327 D
4,360,947	11/1982	DeCosa et al.	15/323
4,363,674	12/1982	Fullenwider	15/301
4,388,090	6/1983	Streeter	55/229
4,437,866	3/1984	Pueblo	261/DIG. 9
4,497,308	2/1985	Johnson	15/327 F
4,529,421	7/1985	Parma	261/17
4,738,695	4/1988	Carr et al.	55/229
4,807,590	2/1989	Evans	15/319
4,859,219	8/1989	Huang	261/17
4,977,638	12/1990	Best	15/301
4,995,137	2/1991	Richborn	15/327.1
5,029,535	7/1991	Krigmont et al.	55/DIG. 30
5,041,274	8/1991	Kagi, Sr.	261/DIG. 9
5,143,527	9/1992	Tian-Song	261/DIG. 9
5,160,707	11/1992	Murray et al.	291/17

[57] CLAIM

The ornamental design for an emissions scrubber for wood burning units, as shown and described.

DESCRIPTION

FIG. 1 is a front, top and side perspective view of the emissions scrubber for wood burning units showing my new design, the duct connecting the scrubber unit to a chimney exhaust end connection element being broken away for ease of illustration;

FIG. 2 is a front elevational view thereof;

FIG. 3 is a rear elevational view thereof;

FIG. 4 is a side elevational view thereof, the side opposite being a mirror image of the side shown in FIG. 4;

FIG. 5 is a top plan view thereof; and,

FIG. 6 is a bottom plan view thereof.

1 Claim, 4 Drawing Sheets

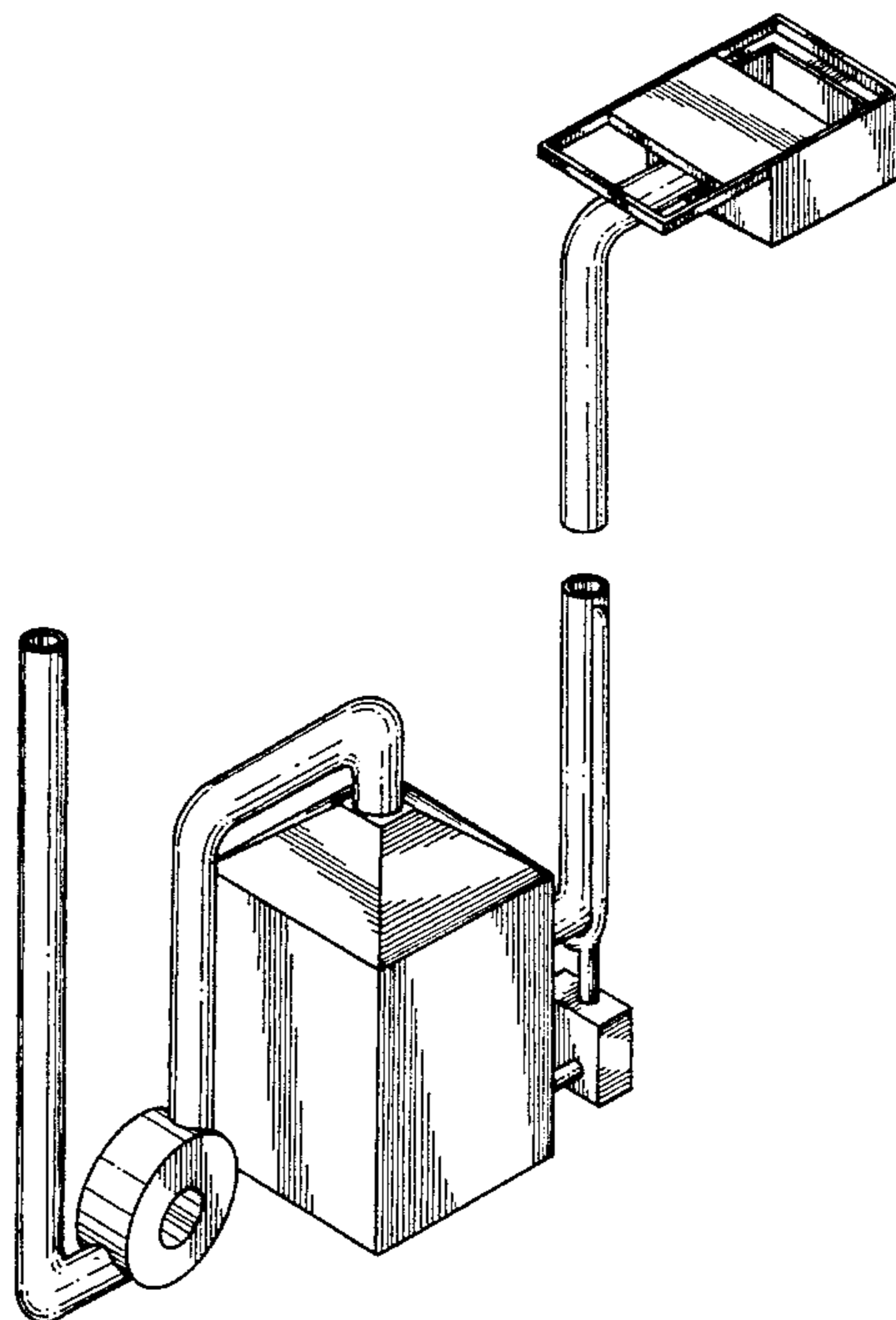

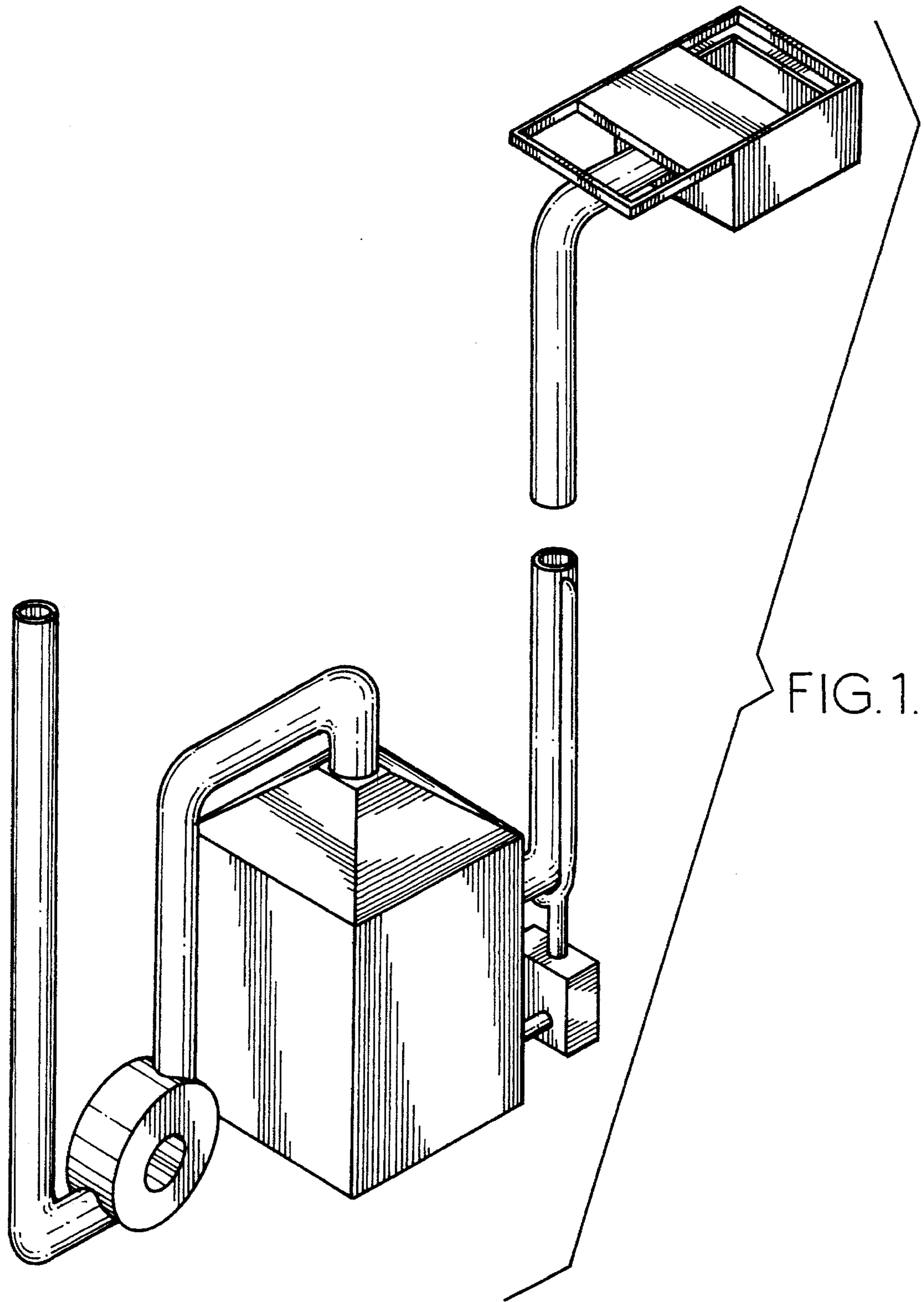

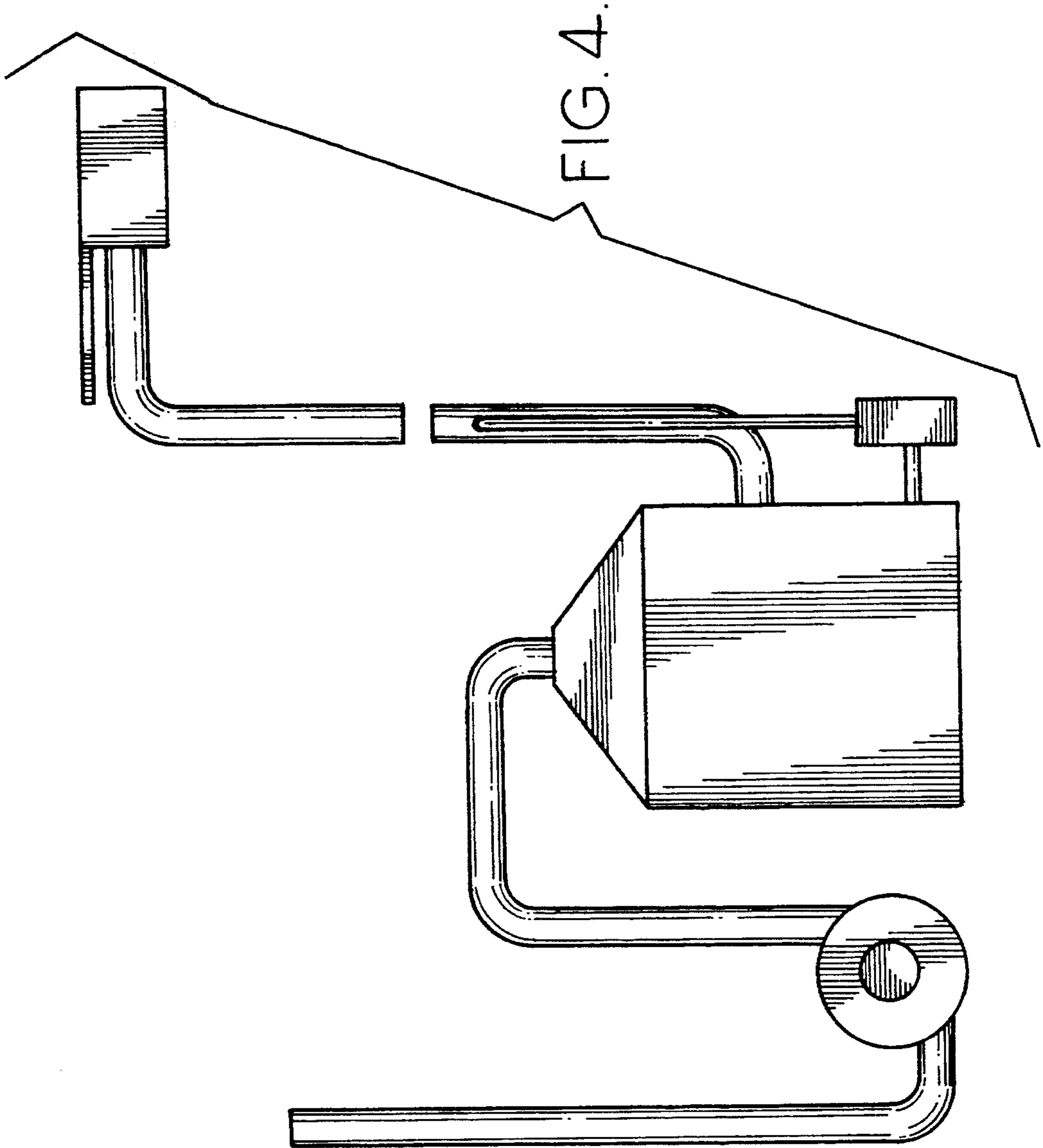
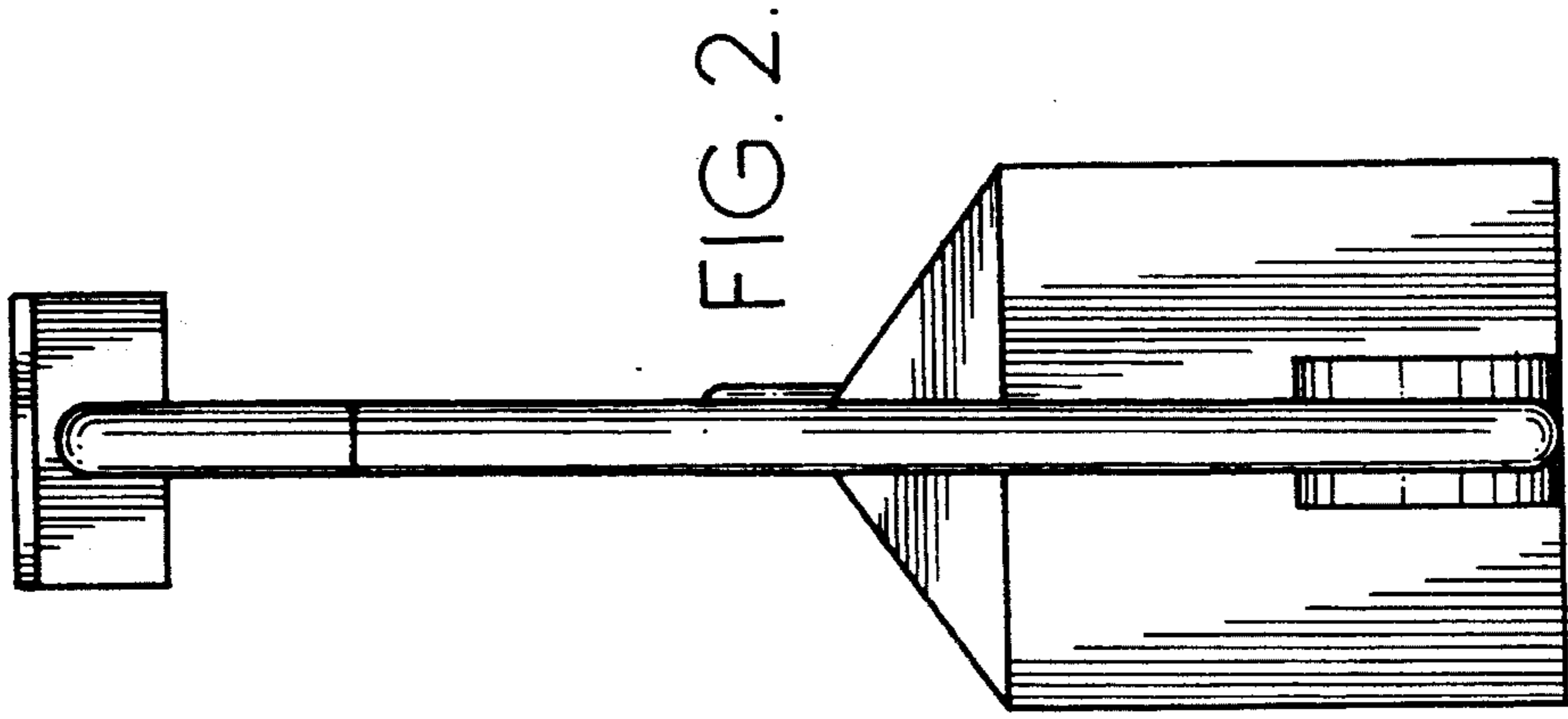

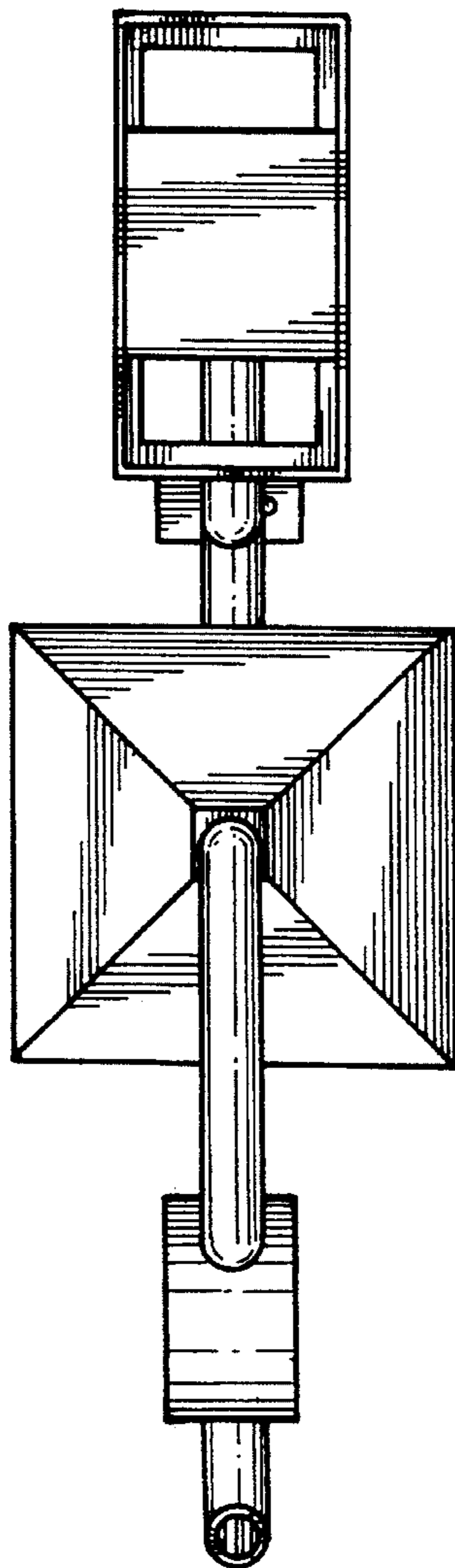
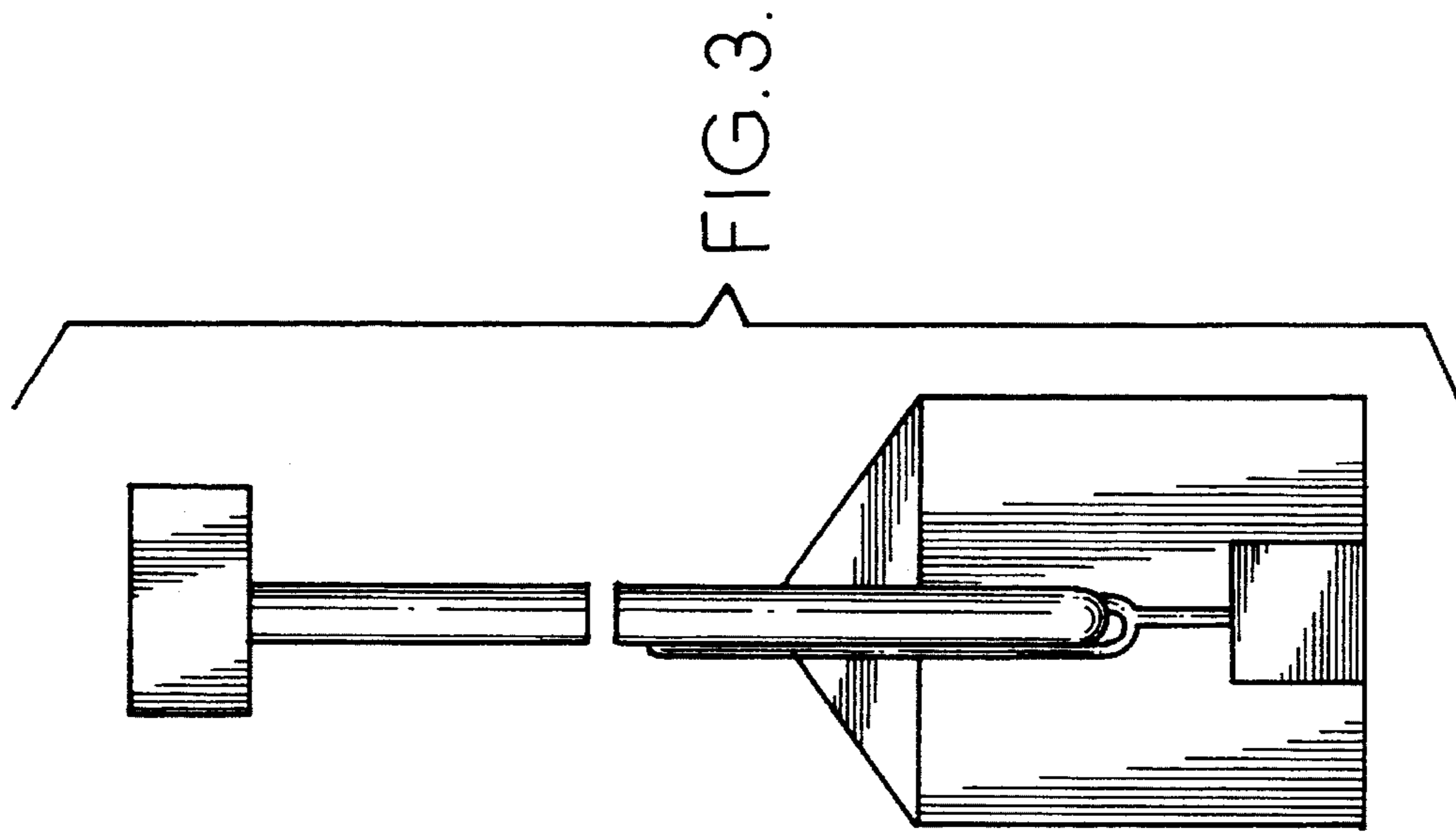

FIG. 6.

