



US00D364878S

United States Patent [19]

Green et al.

[11] Patent Number: **Des. 364,878**

[45] Date of Patent: ****Dec. 5, 1995**

[54] **CONTROL PANEL FOR A COMBINED VEHICULAR RADIO RECEIVER, CASSETTE PLAYER AND DIGITAL CLOCK**

[75] Inventors: **Dewayne E. Green**, Winchester, Tenn.; **Michael B. Sestina**; **Steven F. Selby**, both of Huntsville, Ala.; **Charles Wright**, Decatur Huntsville, Ala.; **George C. Lew**, Clarkston, Mich.; **Douglas L. Brundage**, Harvest, Ala.

[73] Assignee: **Chrysler Corporation**, Highland Park, Mich.

[**] Term: **14 Years**

[21] Appl. No.: **27,824**

[22] Filed: **Aug. 30, 1994**

[52] U.S. Cl. **D14/258**; D14/157

[58] Field of Search D14/157, 257, D14/258, 299; 455/73, 89-90, 128, 345-347

[56] **References Cited**

U.S. PATENT DOCUMENTS

- D. 334,752 4/1993 Dziekan et al. D14/157
- D. 343,842 2/1994 Fowler et al. D14/157

- D. 344,955 3/1994 Dziekan et al. D14/258
- D. 346,609 5/1994 Person et al. D14/157
- D. 350,964 9/1994 Fowler et al. D14/157
- D. 354,962 1/1995 Jazanowski et al. D14/258
- D. 356,092 3/1995 McCauley et al. D14/157

Primary Examiner—Sandra L. Morris
Attorney, Agent, or Firm—Christopher A. Taravella

[57] **CLAIM**

The ornamental design for a control panel for a combined vehicular radio receiver, cassette player and digital clock, as shown and described.

DESCRIPTION

FIG. 1 is a front, top and left side perspective view of a control panel for a combined vehicular radio receiver, cassette player and digital clock;
 FIG. 2 is a top plan view thereof;
 FIG. 3 is a front elevational view thereof;
 FIG. 4 is a bottom plan view thereof;
 FIG. 5 is a left side elevational view thereof; and,
 FIG. 6 is a right side elevational view thereof.
 The broken line showing of the housing in the drawing figures is for illustrative purposes only and forms no part of the claimed design.

1 Claim, 2 Drawing Sheets

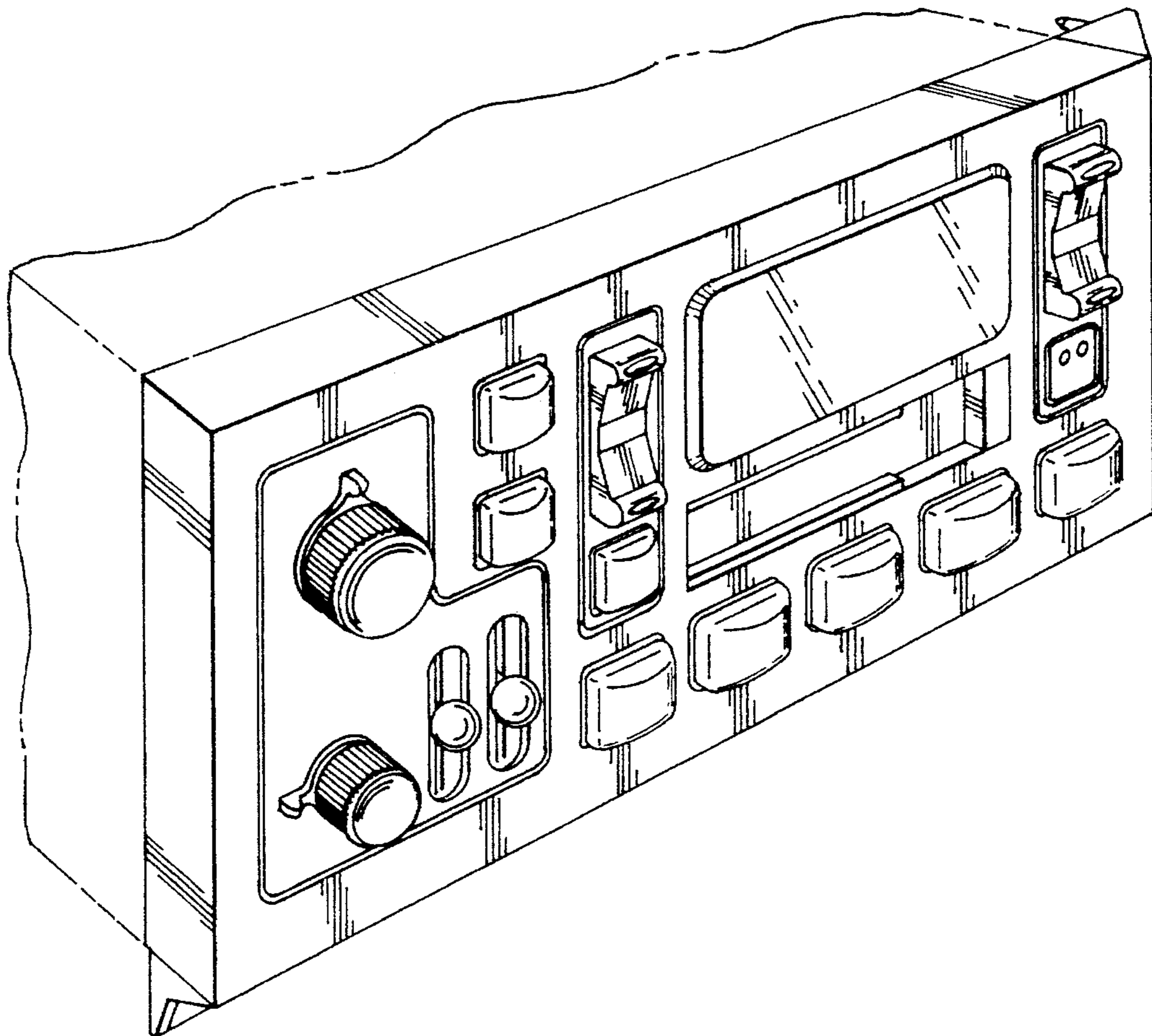

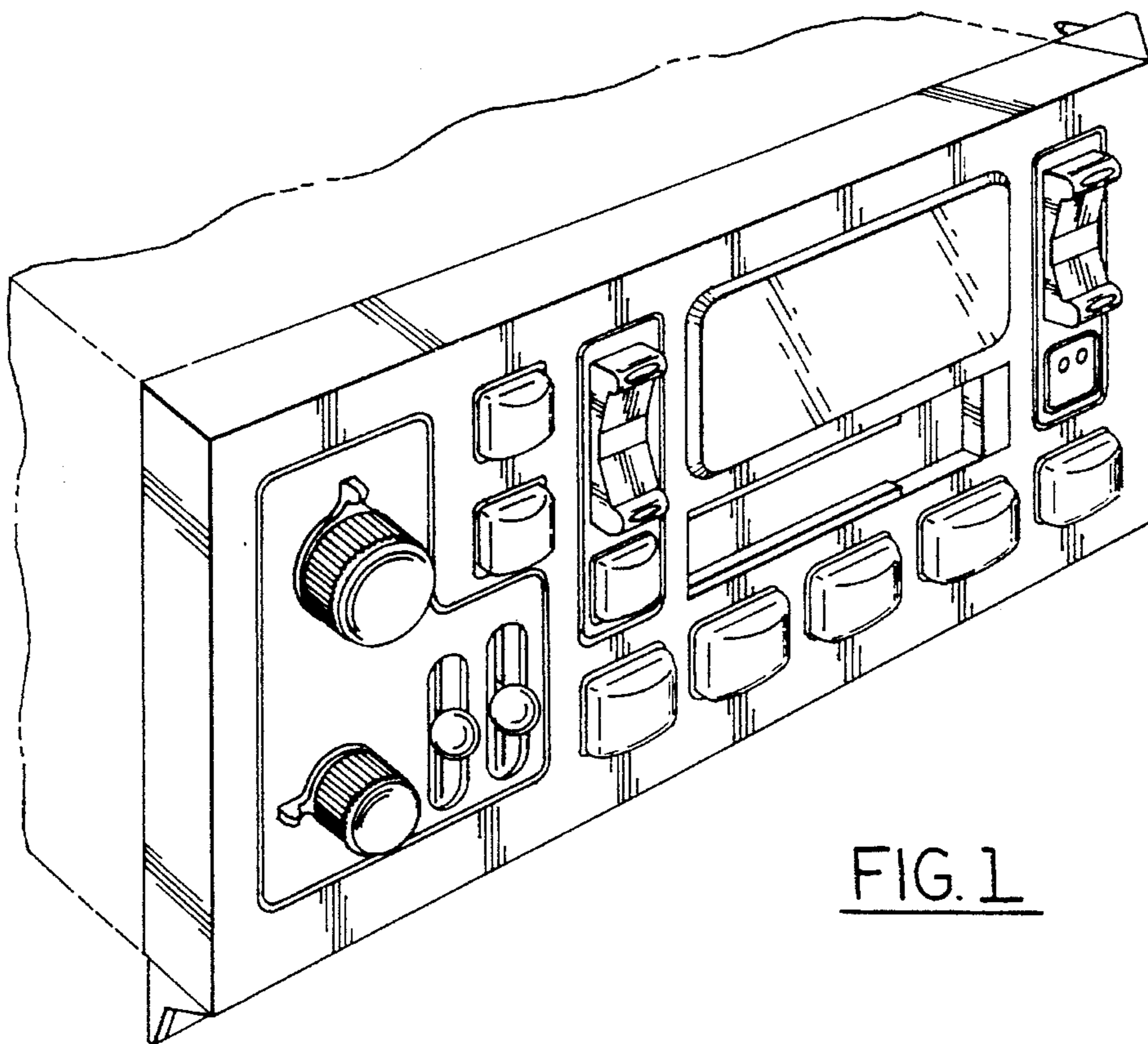

FIG. 1

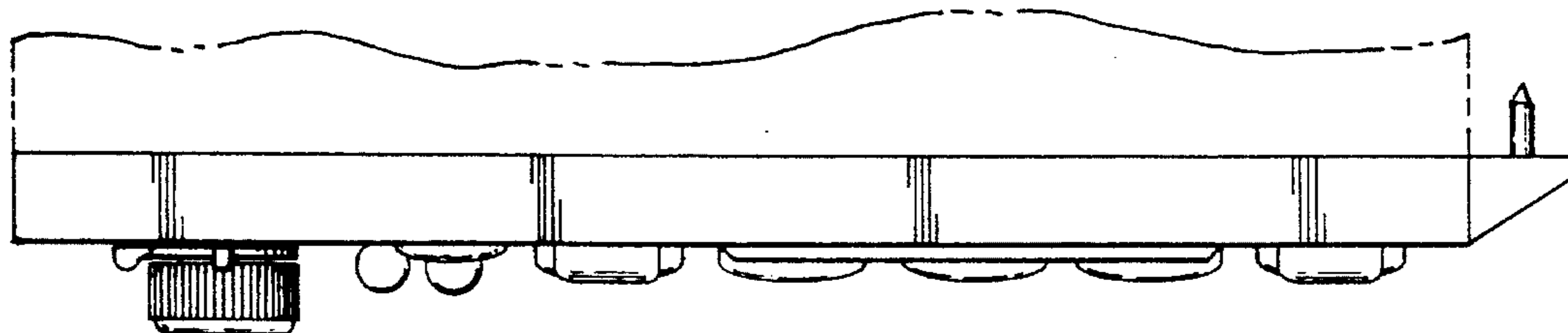

FIG. 2

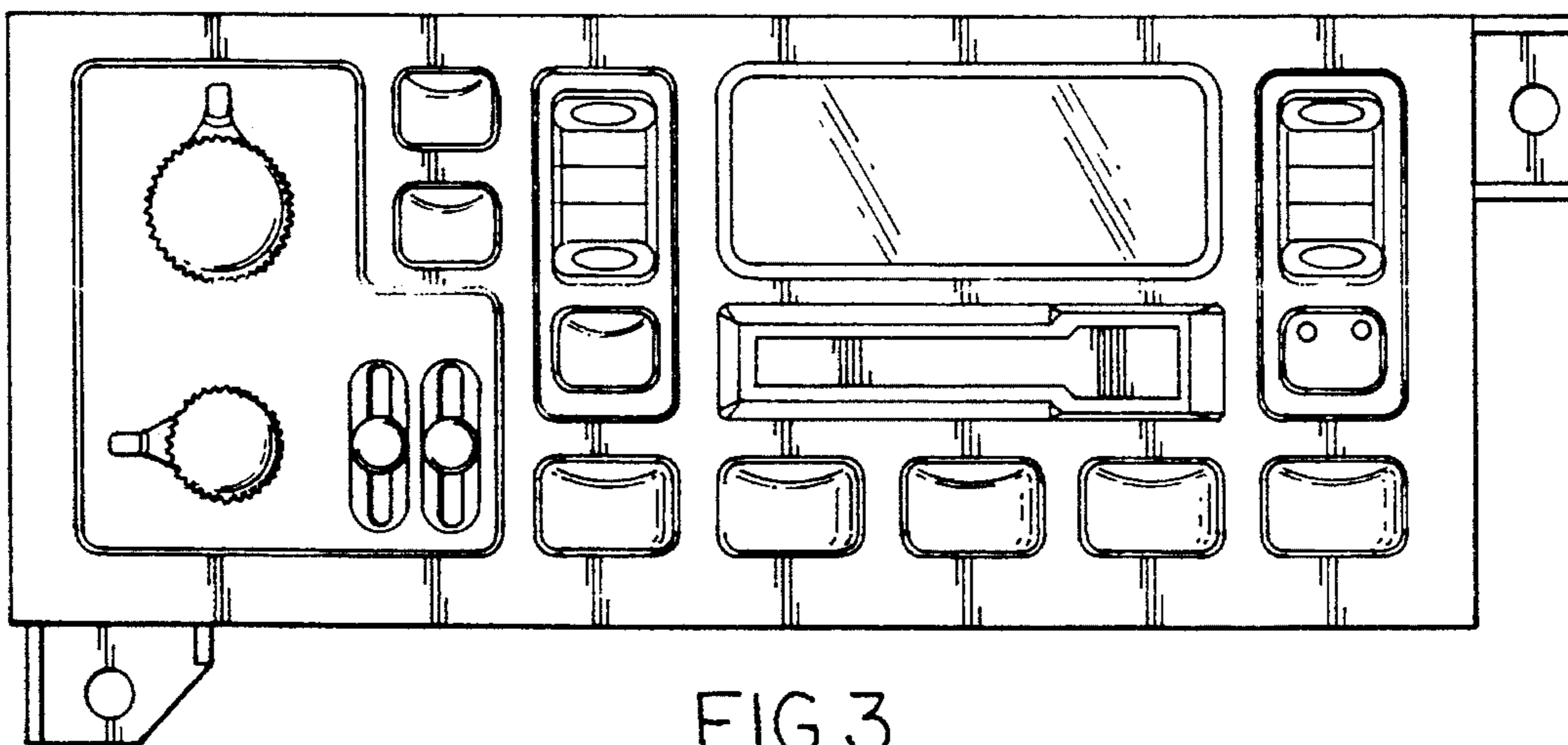

FIG. 3

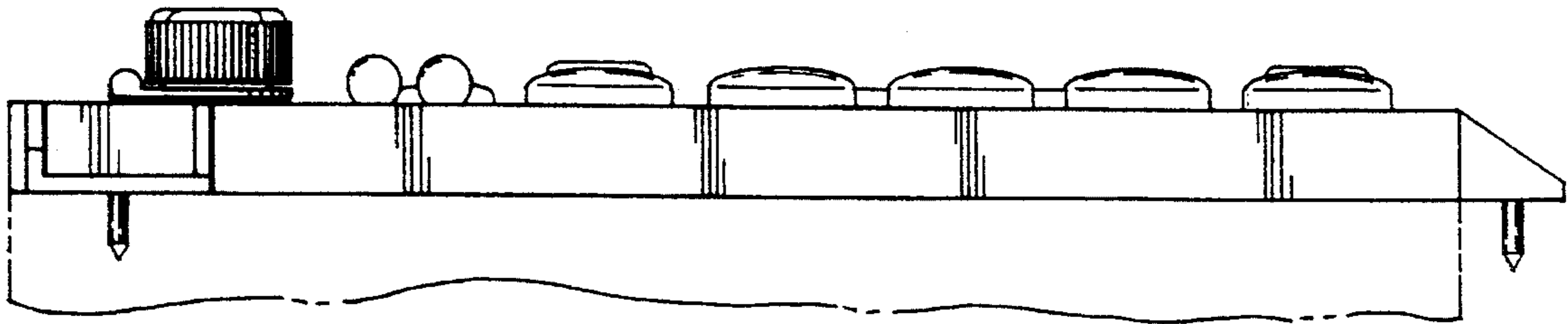

FIG. 4

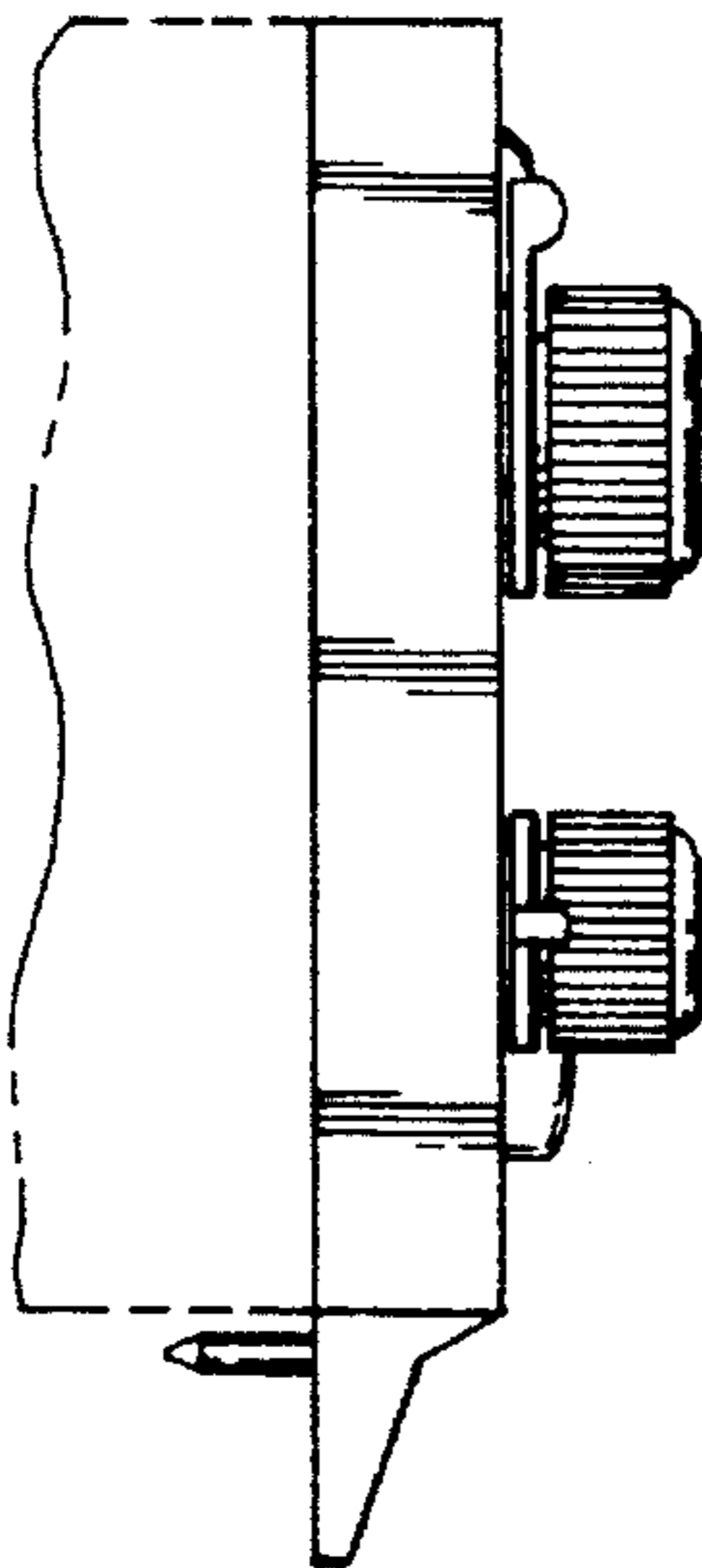

FIG. 5

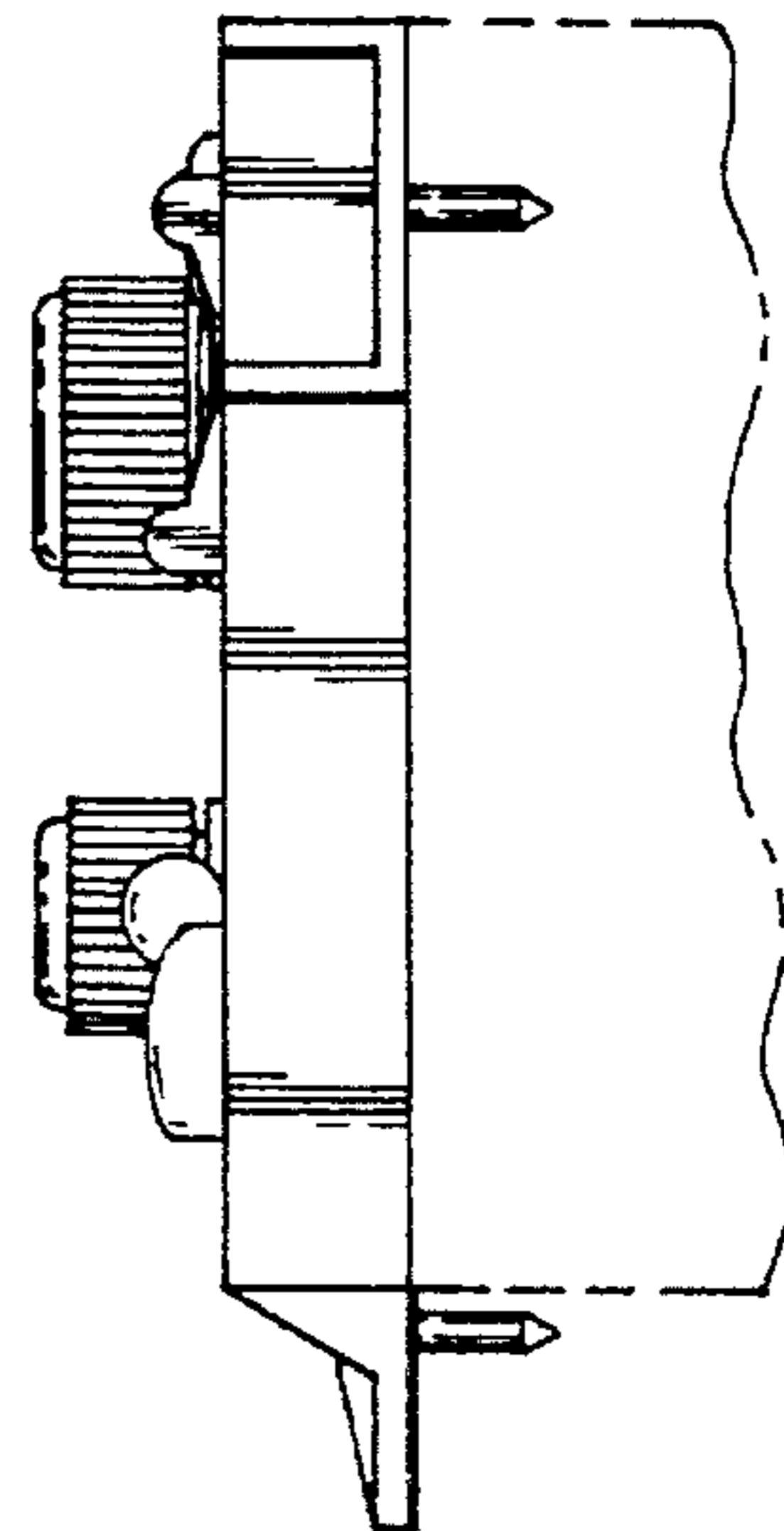

FIG. 6