



US00D364639S

United States Patent [19]

[11] Patent Number: **Des. 364,639**

Tashiro

[45] Date of Patent: ***** Nov. 28, 1995**

[54] **PRINTER FOR ELECTRONIC COMPUTER**

[75] Inventor: **Naoki Tashiro**, Kawasaki, Japan

[73] Assignee: **Canon Kabushiki Kaisha**, Tokyo, Japan

[*] Notice: The portion of the term of this patent subsequent to Nov. 1, 2008, has been disclaimed.

[**] Term: **14 Years**

[21] Appl. No.: **20,556**

[22] Filed: **Mar. 28, 1994**

[30] **Foreign Application Priority Data**

Sep. 29, 1993 [JP] Japan 5-29391

[52] **U.S. Cl.** **D18/50**

[58] **Field of Search** D18/50, 51, 52, D18/54, 55, 19; 400/690-694, 619.1-619.4, 613, 613.1-613.4, 88; D14/106

[56] **References Cited**

U.S. PATENT DOCUMENTS

D. 285,211	8/1986	Nibley et al.	D18/12
D. 321,002	10/1991	Tashiro et al.	D18/54
D. 321,711	11/1991	Yoshihara et al.	D18/54
D. 322,981	1/1992	Tokuda	D18/54
D. 322,982	1/1992	Tashiro	D18/54
D. 323,344	1/1992	Umino et al.	D18/54
D. 330,721	11/1992	Yoshihara	D18/50
D. 333,130	2/1993	Amber et al.	D14/106
D. 337,608	7/1993	Miyamoto	D18/55
D. 338,271	8/1993	Yoshikawa et al.	D18/50

D. 338,487	8/1993	Martin	D18/50
D. 339,156	9/1993	Sato et al.	D18/50
D. 339,157	9/1993	Miyamoto et al.	D18/50
D. 339,158	9/1993	Sato	D18/50
D. 339,372	9/1993	Kando	D18/50
D. 340,065	10/1993	Fukuda	D18/50
D. 343,167	1/1994	Mizusugi et al.	D14/106
D. 343,407	1/1994	Kando	D14/106
D. 343,411	1/1994	Chen	D18/50
D. 343,637	1/1994	Umino et al.	D18/55
D. 352,056	11/1994	Kawashima et al.	D18/50
D. 352,057	11/1994	Tashiro	D18/50
D. 353,154	12/1994	Suzuki	D18/50

OTHER PUBLICATIONS

Canon BJ-10e Bubble Jet Printer brochure; back cover.
Seikosha LT-20 brochure by Seiko; cover photograph.

Primary Examiner—Cathy Anne MacCormac
Attorney, Agent, or Firm—Fitzpatrick, Cella, Harper & Scinto

[57] **CLAIM**

The ornamental design for a printer for electronic computer, as shown and described.

DESCRIPTION

FIG. 1 is a front elevational view of a printer for electronic computer informing my new design;
FIG. 2 is a rear elevational view thereof;
FIG. 3 is a top plan view thereof;
FIG. 4 is a bottom plan view thereof;
FIG. 5 is a left side elevational view thereof;
FIG. 6 is a right side elevational view thereof; and,
FIG. 7 is a perspective view thereof.

1 Claim, 2 Drawing Sheets

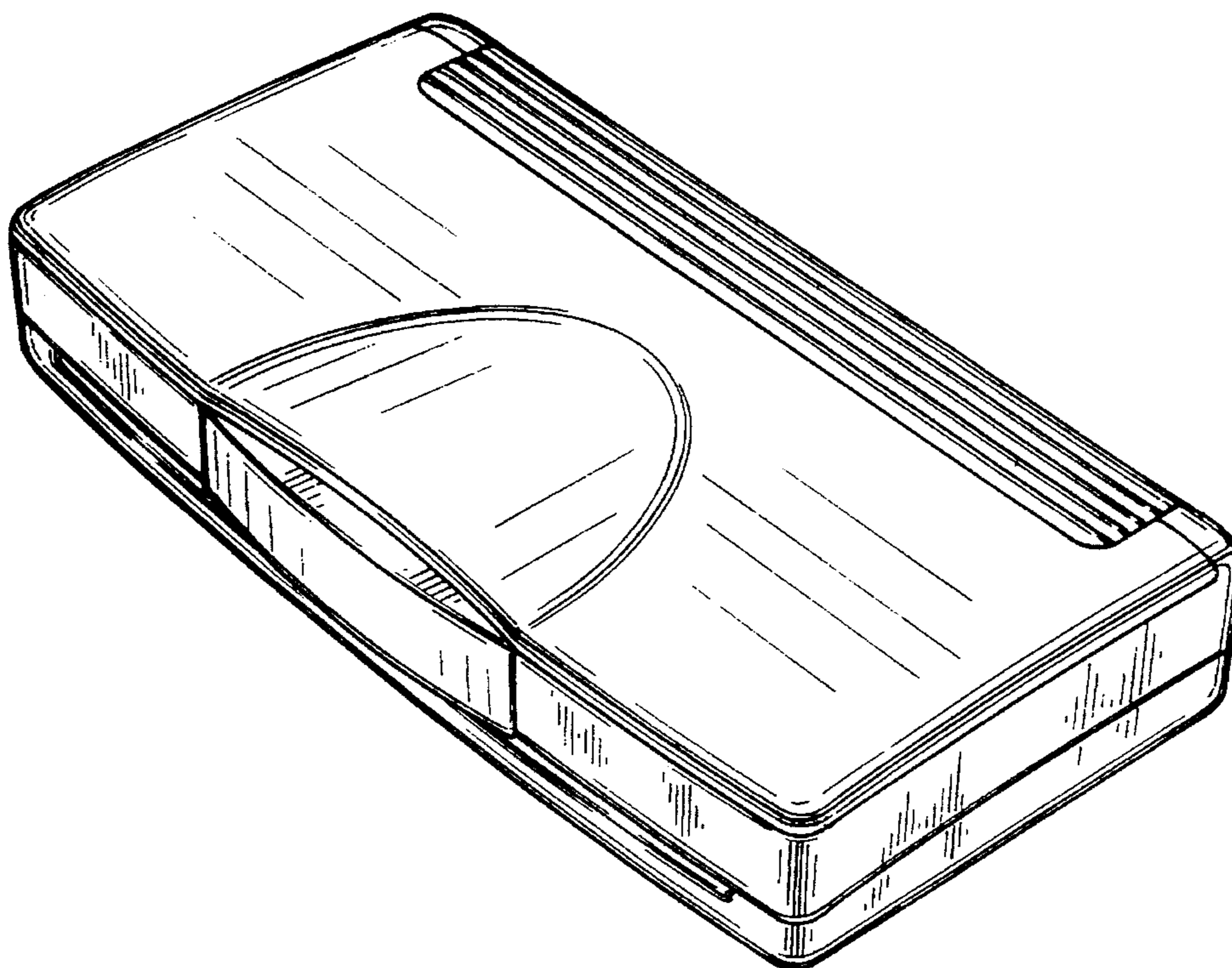

FIG. 1

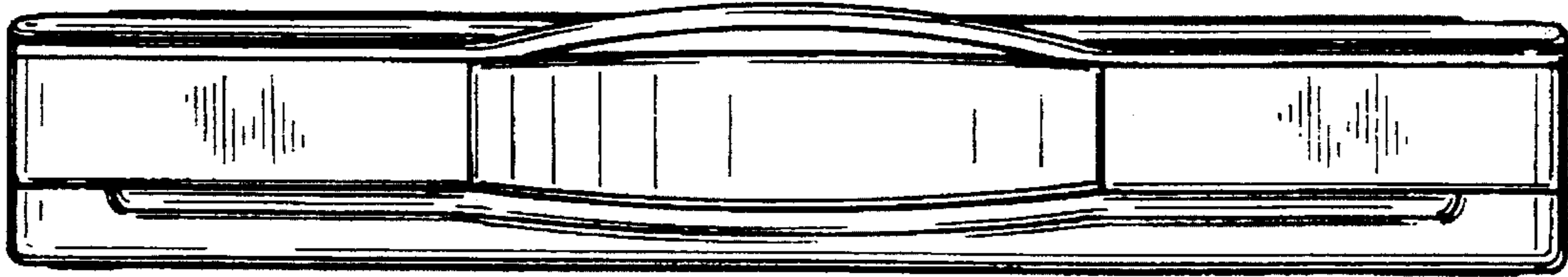

FIG. 2

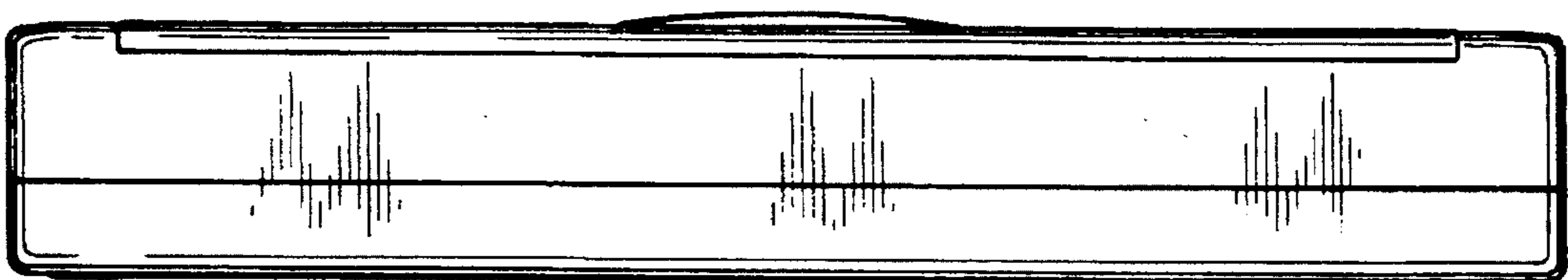

FIG. 3

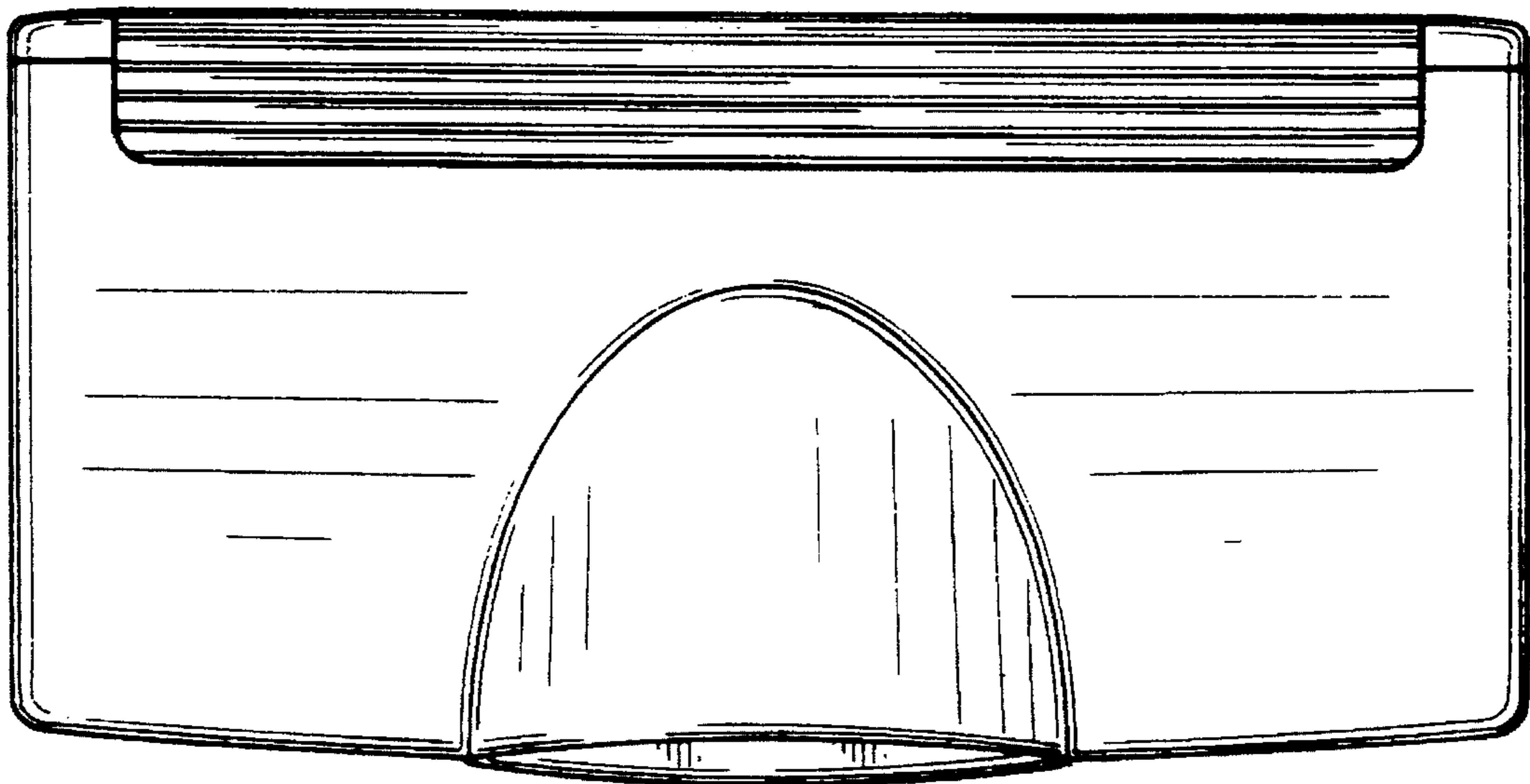

FIG. 4

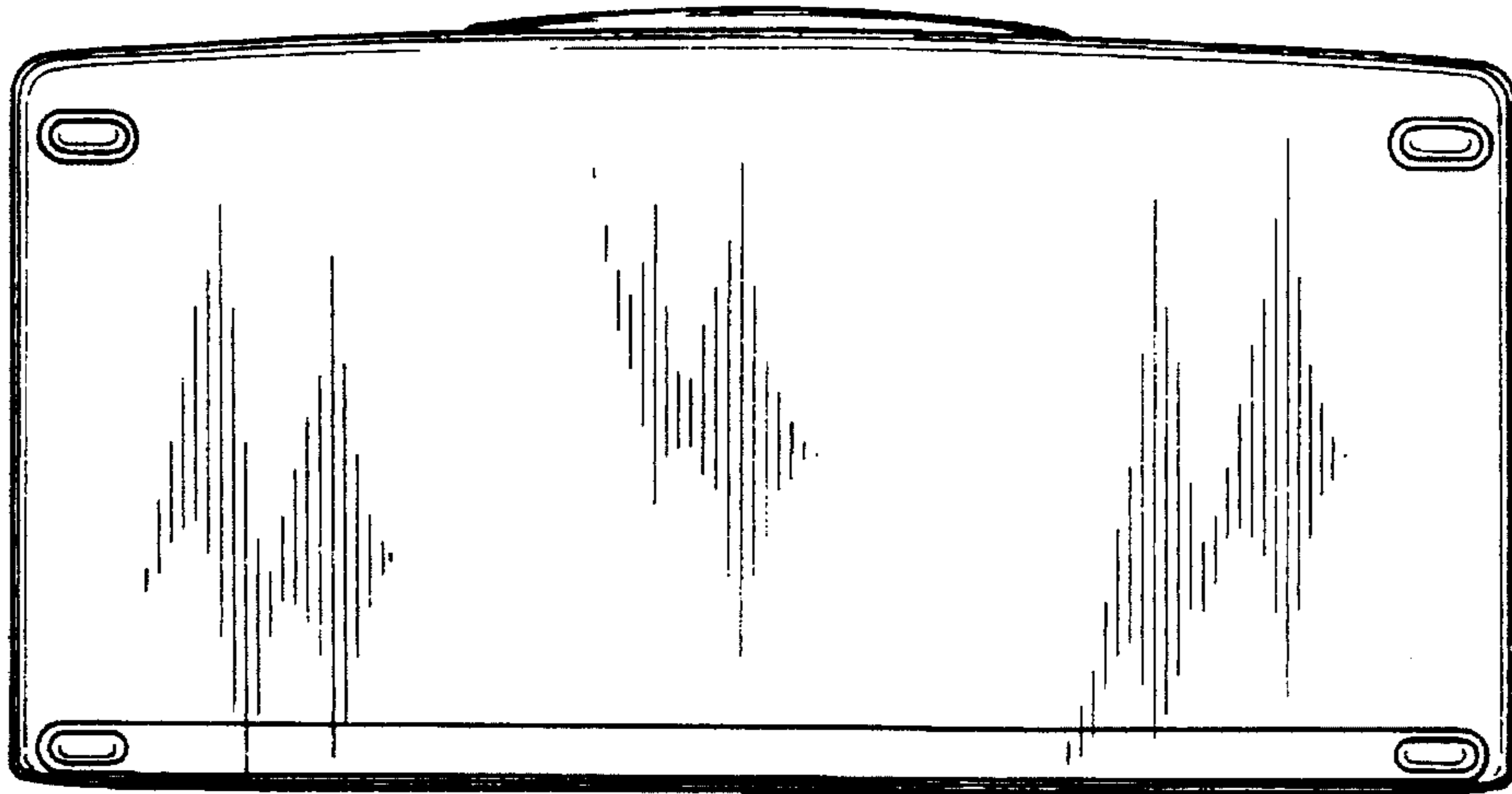

FIG. 5

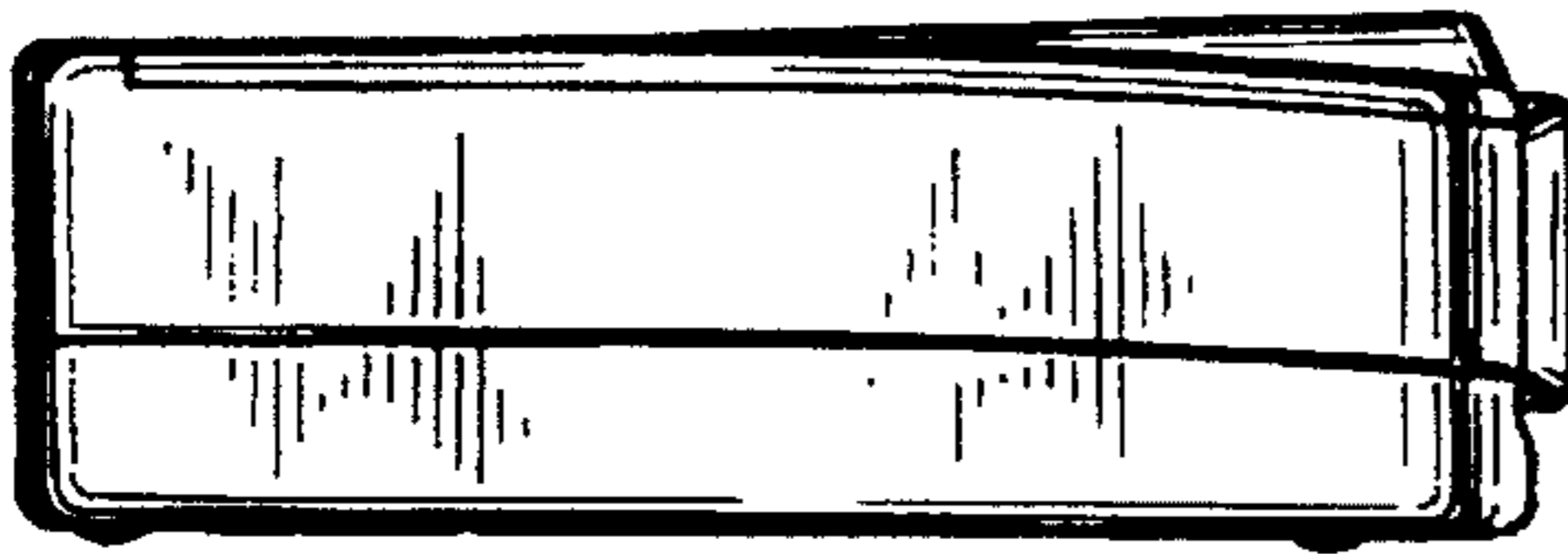

FIG. 6

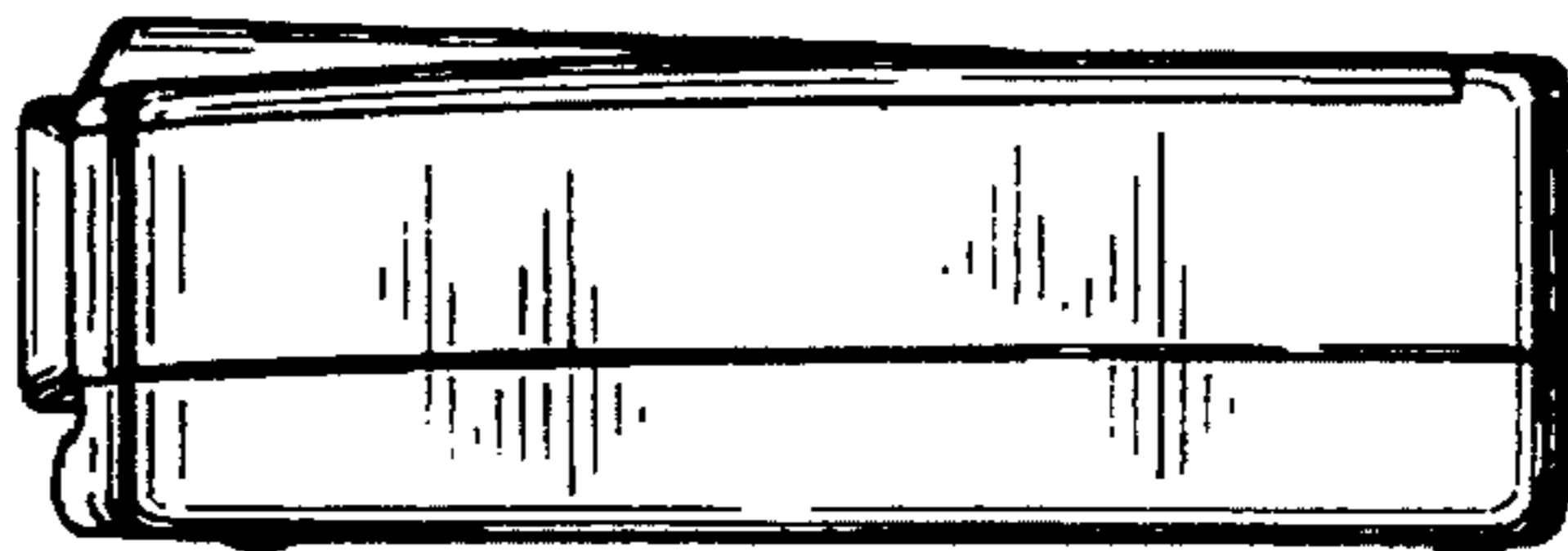

FIG. 7

