



US00D364626S

United States Patent [19]

[11] Patent Number: **Des. 364,626**

Brown

[45] Date of Patent: ****Nov. 28, 1995**

[54] **COMBINED ENGINE CYLINDER AND HEAD**

4,660,512	4/1987	Binder et al.	123/41.6
4,747,374	5/1988	Stadler	123/416
4,757,872	7/1988	Inomata	180/291
4,971,171	11/1990	Yamada et al.	180/68.1

[76] Inventor: **Charles R. Brown**, 8038 SE. Ogden, Portland, Oreg. 97206

[**] Term: **14 Years**

Primary Examiner—Ralf T. Seifert
Attorney, Agent, or Firm—Marger Johnson McCollom & Stolowitz

[21] Appl. No.: **17,744**

[22] Filed: **Jan. 21, 1994**

[57] **CLAIM**

[52] U.S. Cl. **D15/5**

The ornamental design for a combined engine cylinder and head, as shown and described.

[58] Field of Search D15/1-5; 123/416, 123/41.6, 41.61, 193, 41.69, 68.1, 291; D21/80

DESCRIPTION

[56] **References Cited**

U.S. PATENT DOCUMENTS

44,614	9/1913	Neracher	D15/5
47,673	8/1915	Shultz	D15/5
307,610	5/1990	Harrod	D21/80
3,659,568	5/1972	Howe	123/41.69
4,066,057	6/1978	Hale	123/193
4,633,823	6/1987	Haas et al.	123/41.61

FIG. 1 is a rear elevational view of a combined engine cylinder and head showing my new design; FIG. 2 is a front elevational view thereof; FIG. 3 is a right side, elevational view, the left side being a mirror image thereof; FIG. 4 is a top plan view thereof; and, FIG. 5 is a bottom plan view thereof.

1 Claim, 3 Drawing Sheets

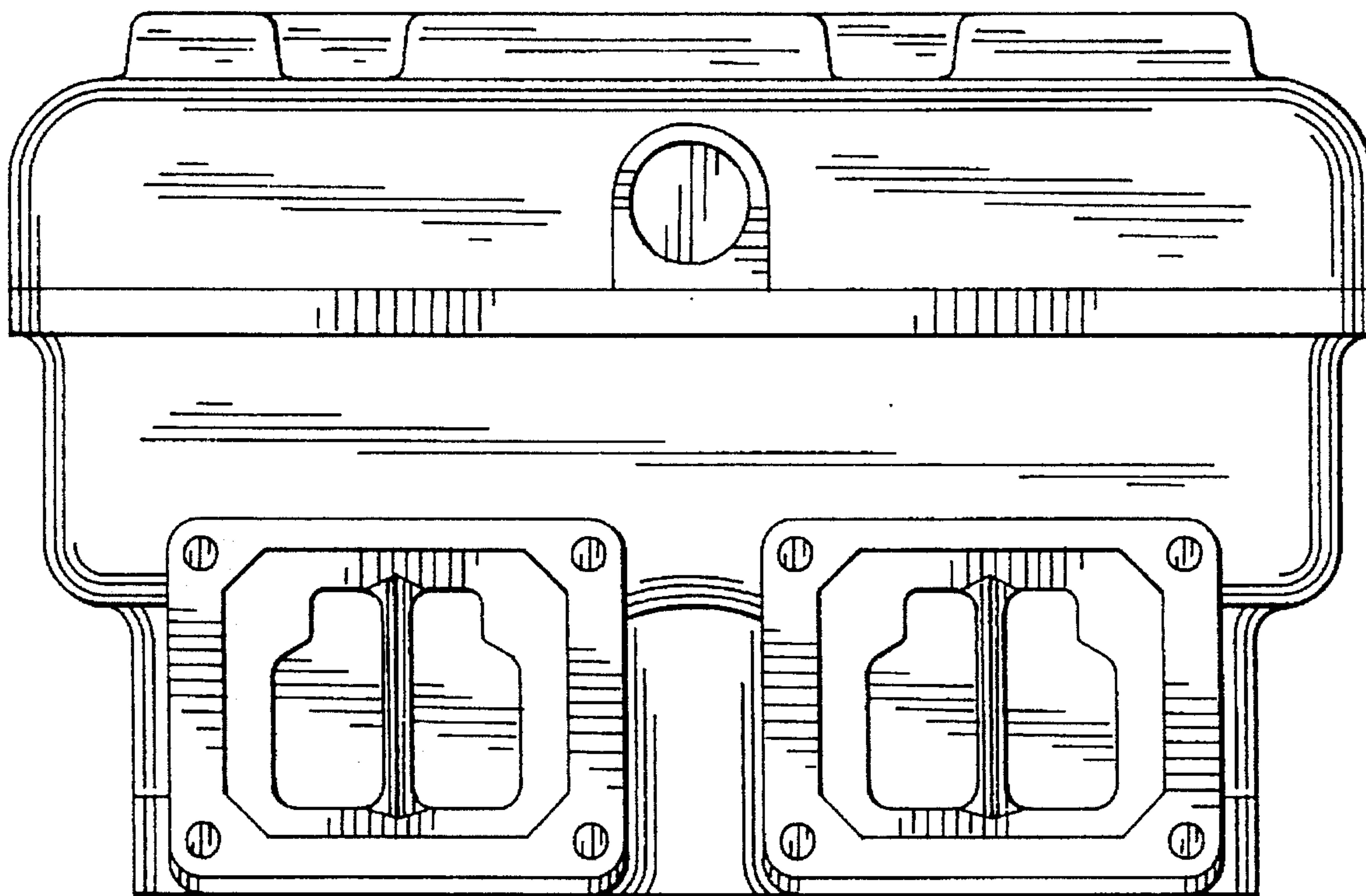

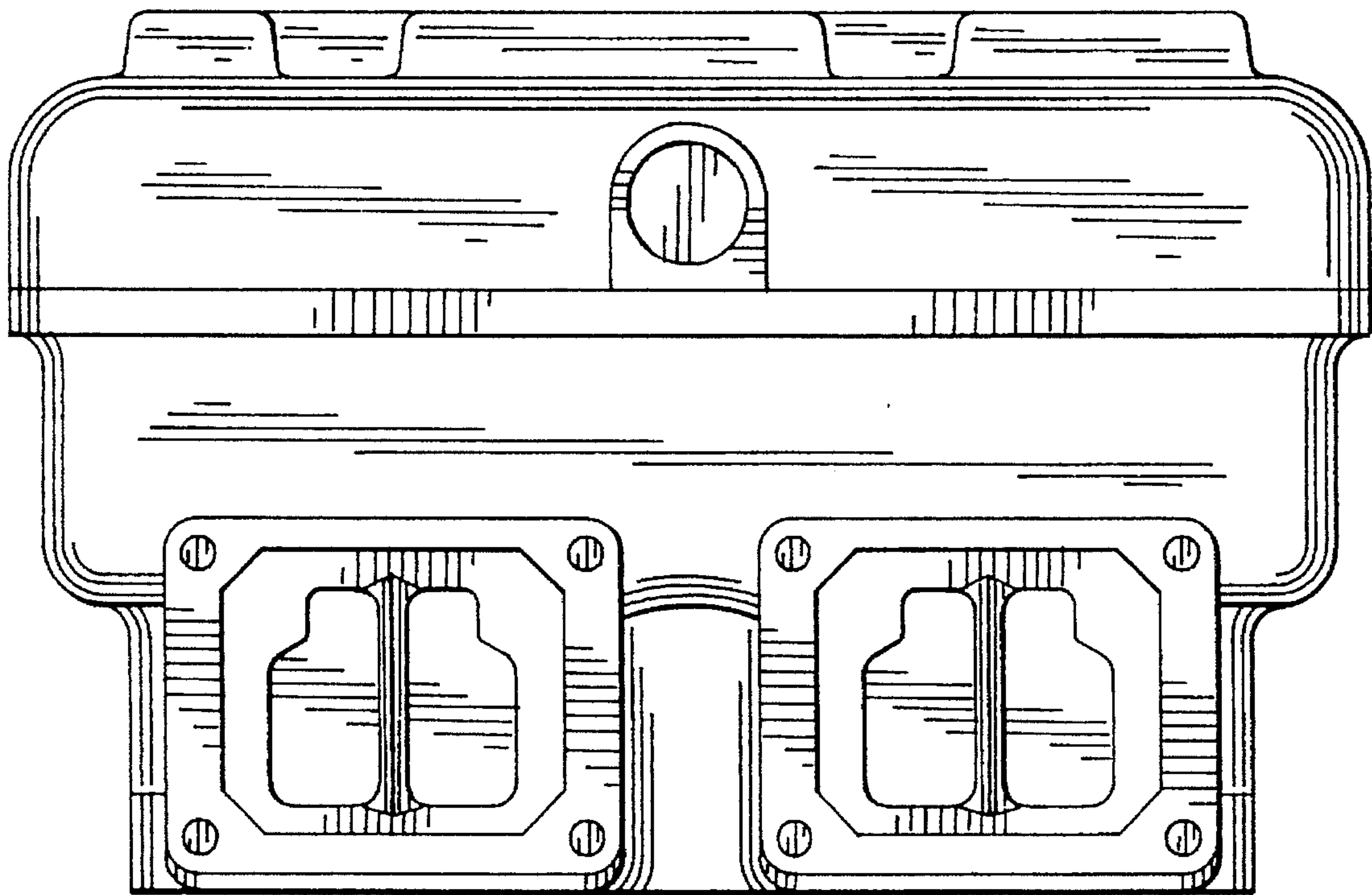

FIG. 1

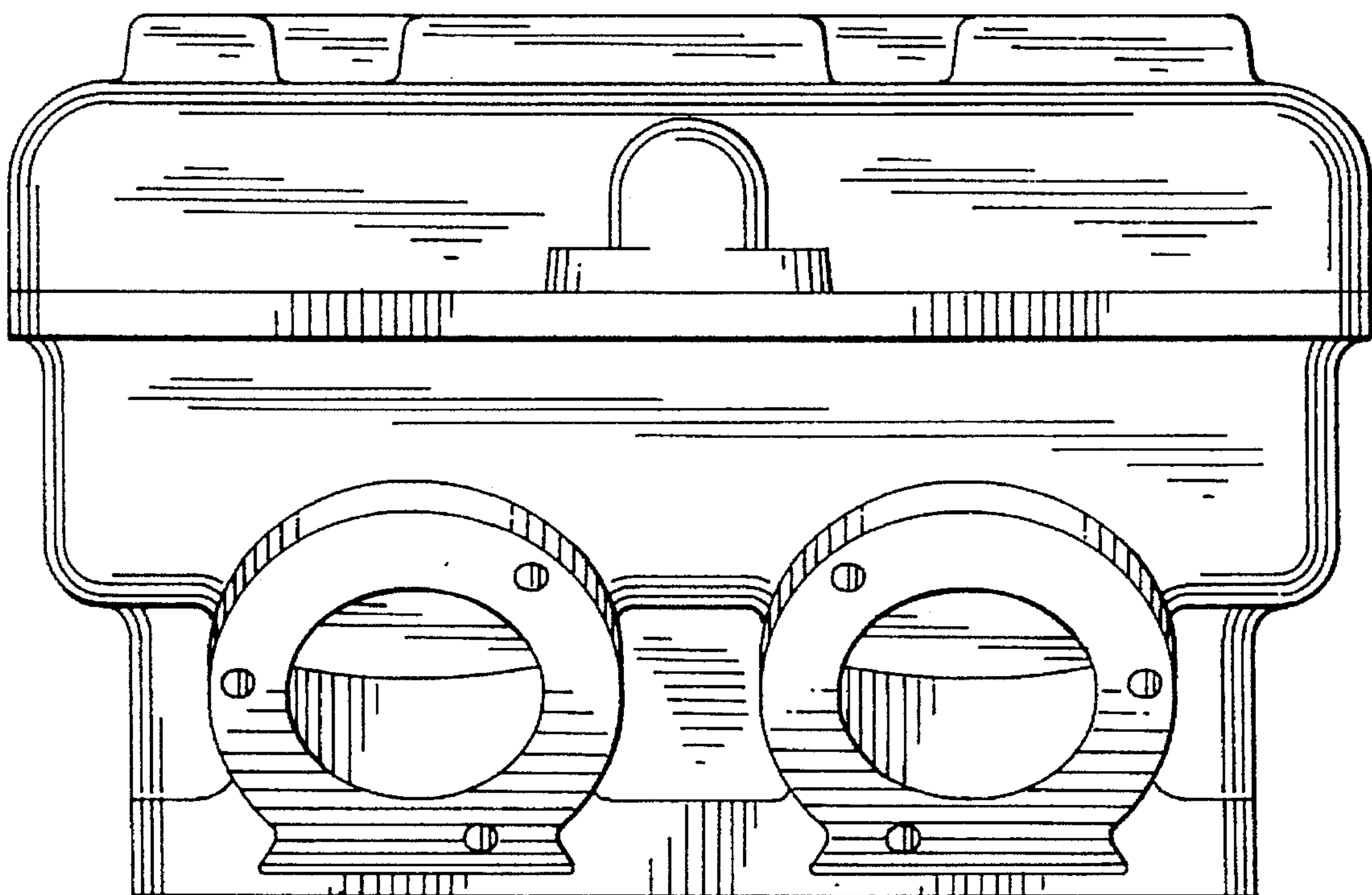

FIG. 2

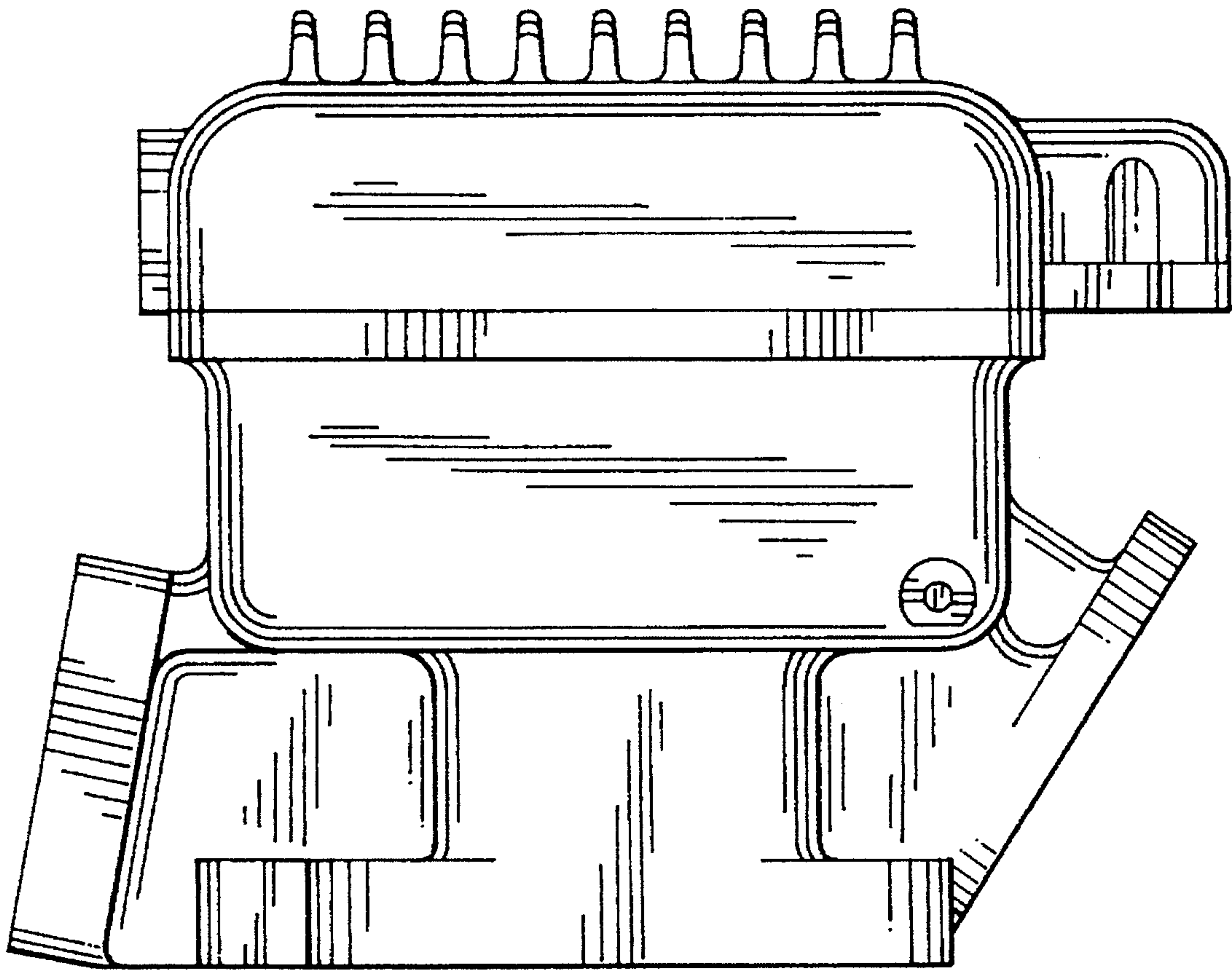

FIG.3

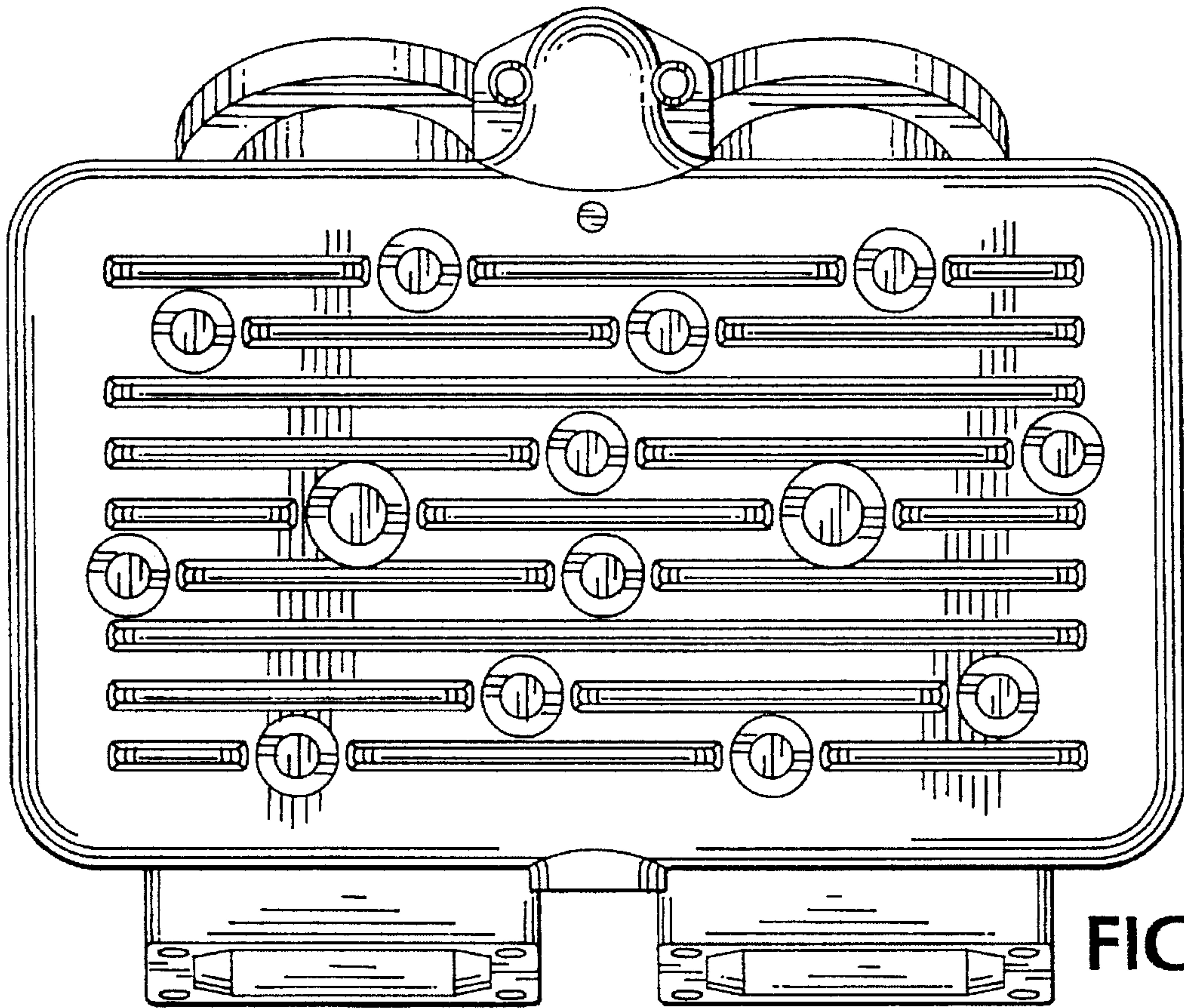

FIG. 4

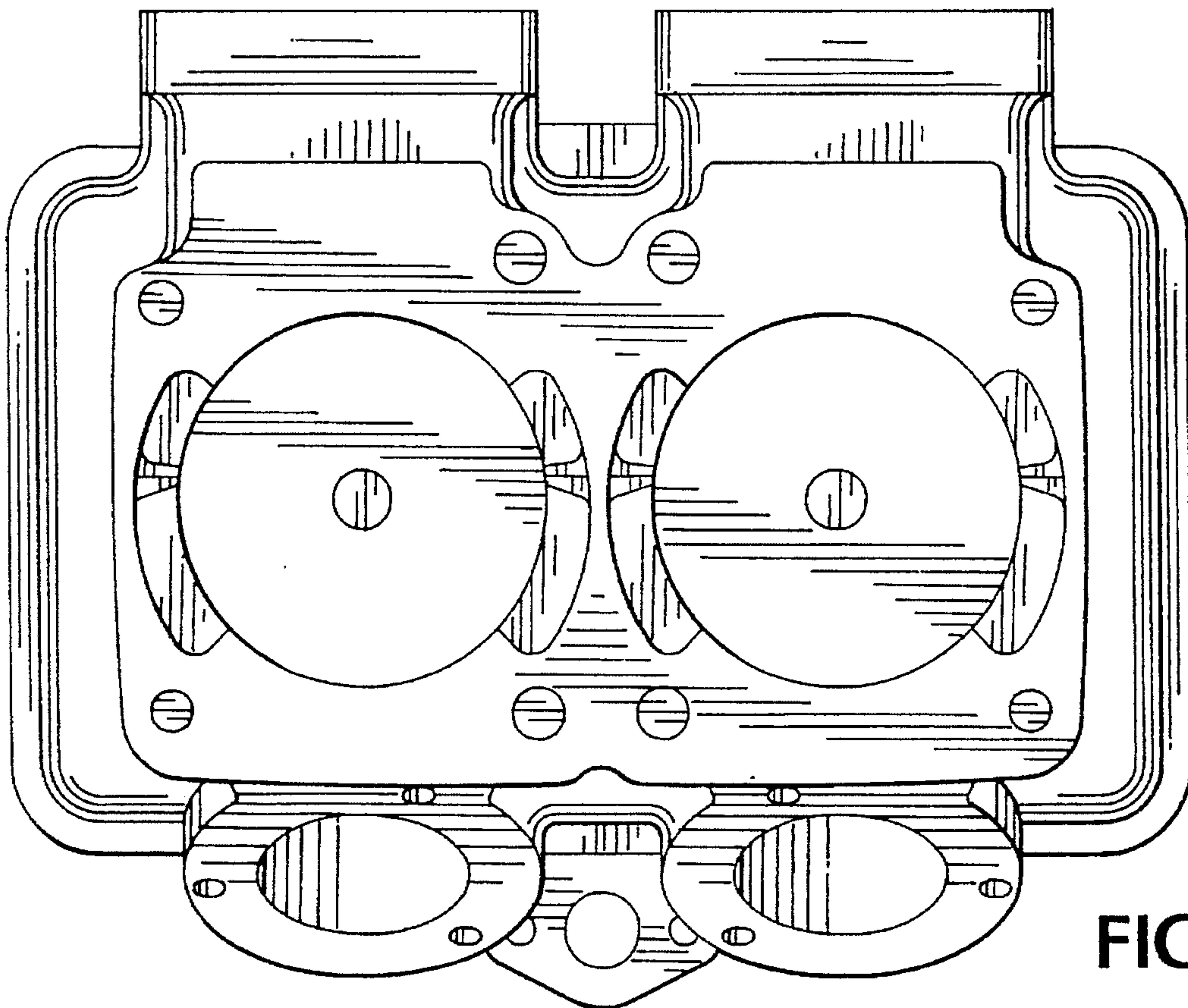

FIG. 5