



US00D364600S

United States Patent [19]
Andrews

[11] **Patent Number: Des. 364,600**
[45] **Date of Patent: **Nov. 28, 1995**

[54] **AIRPLANE**

[75] Inventor: **John J. Andrews**, San Diego, Calif.
[73] Assignee: **The Testor Corporation**, Rockford, Ill.
[**] Term: **14 Years**

[21] Appl. No.: **21,562**
[22] Filed: **Apr. 20, 1994**
[52] U.S. Cl. **D12/333; D12/319**
[58] Field of Search **D12/319, 342, D12/331, 337; 244/158 R, 2, 172**

[56] **References Cited**

U.S. PATENT DOCUMENTS

D. 305,325	1/1990	Andrews	D12/331
4,802,639	2/1989	Hardy et al.	244/158 R
5,082,207	1/1992	Tulinus	244/76 R
5,295,642	3/1994	Palmer	244/2

OTHER PUBLICATIONS

Flight Int'l, 30 Oct. 1975, p. 658, "USAF-NASA X-24 C".
Primary Examiner—Kay H. Chin
Attorney, Agent, or Firm—Fay, Sharpe, Beall, Fagan, Minnich & McKee

[57] **CLAIM**

The ornamental design for an airplane, as shown.

DESCRIPTION

FIG. 1 is a top perspective view of an airplane showing my new design;
FIG. 2 is a top plan view thereof;
FIG. 3 is a left side elevational view thereof, the right side elevational view being a mirror image of that shown;
FIG. 4 is a bottom plan view thereof;
FIG. 5 is a front elevational view thereof; and,
FIG. 6 is a rear elevational view thereof.

1 Claim, 3 Drawing Sheets

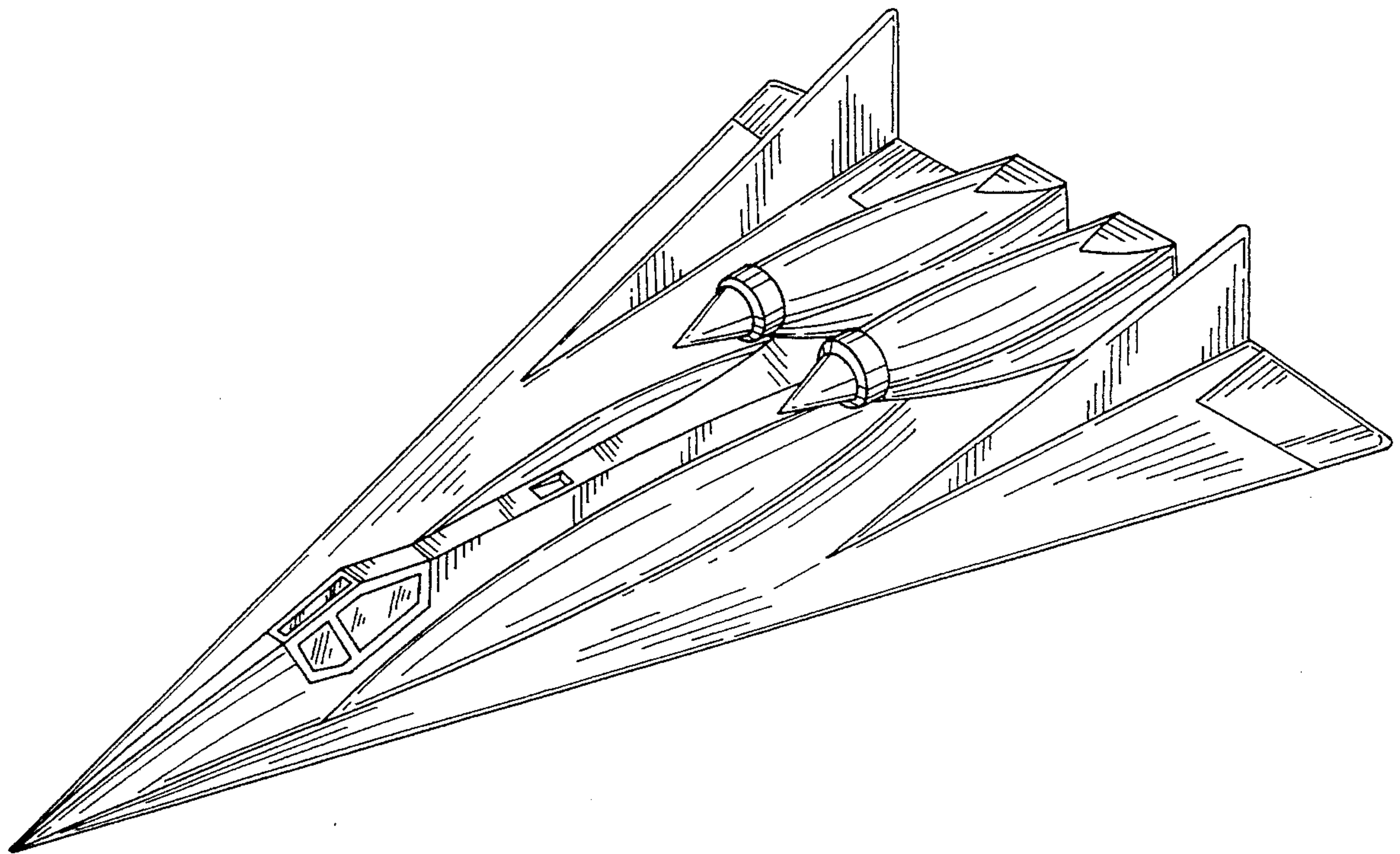

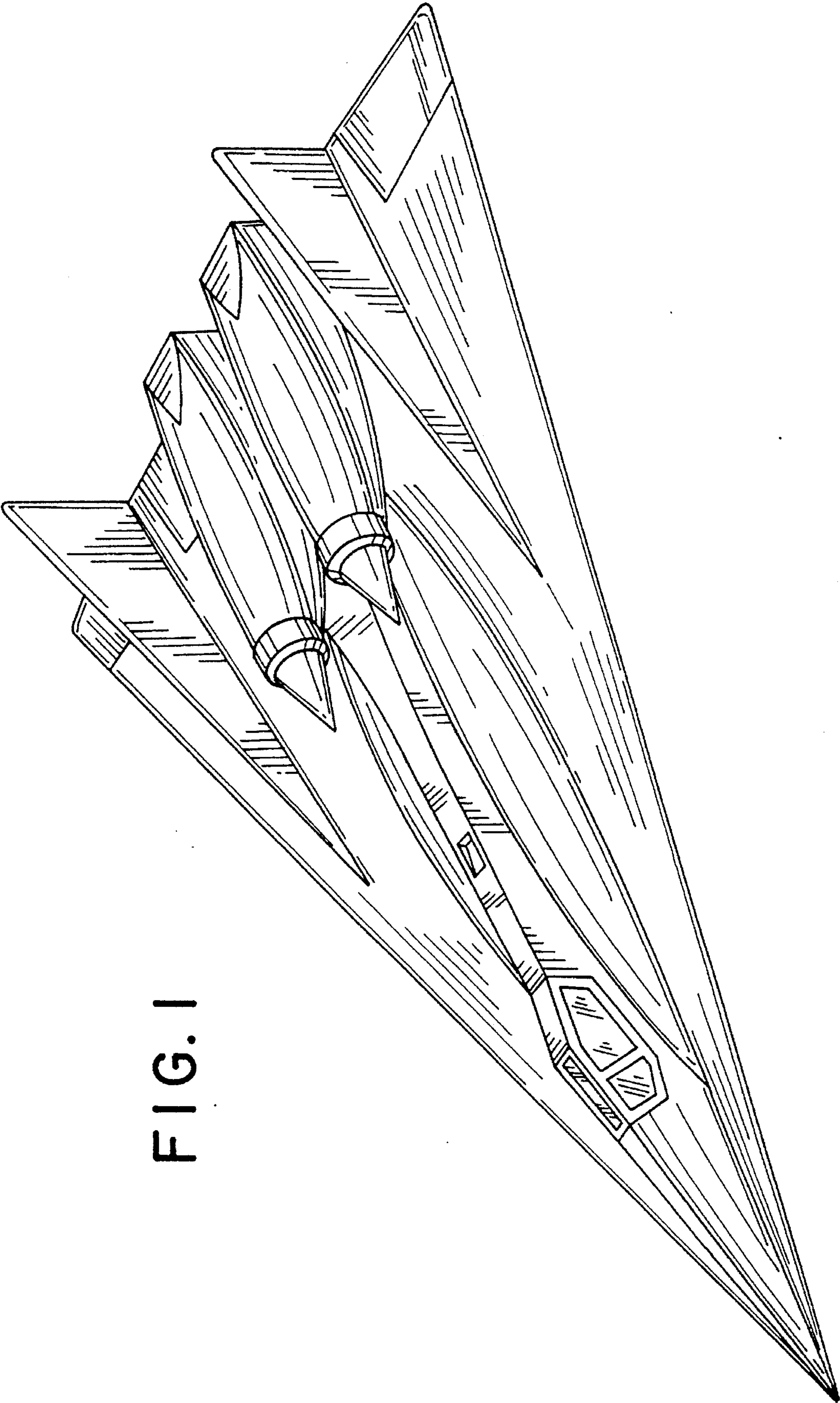

FIG. 1

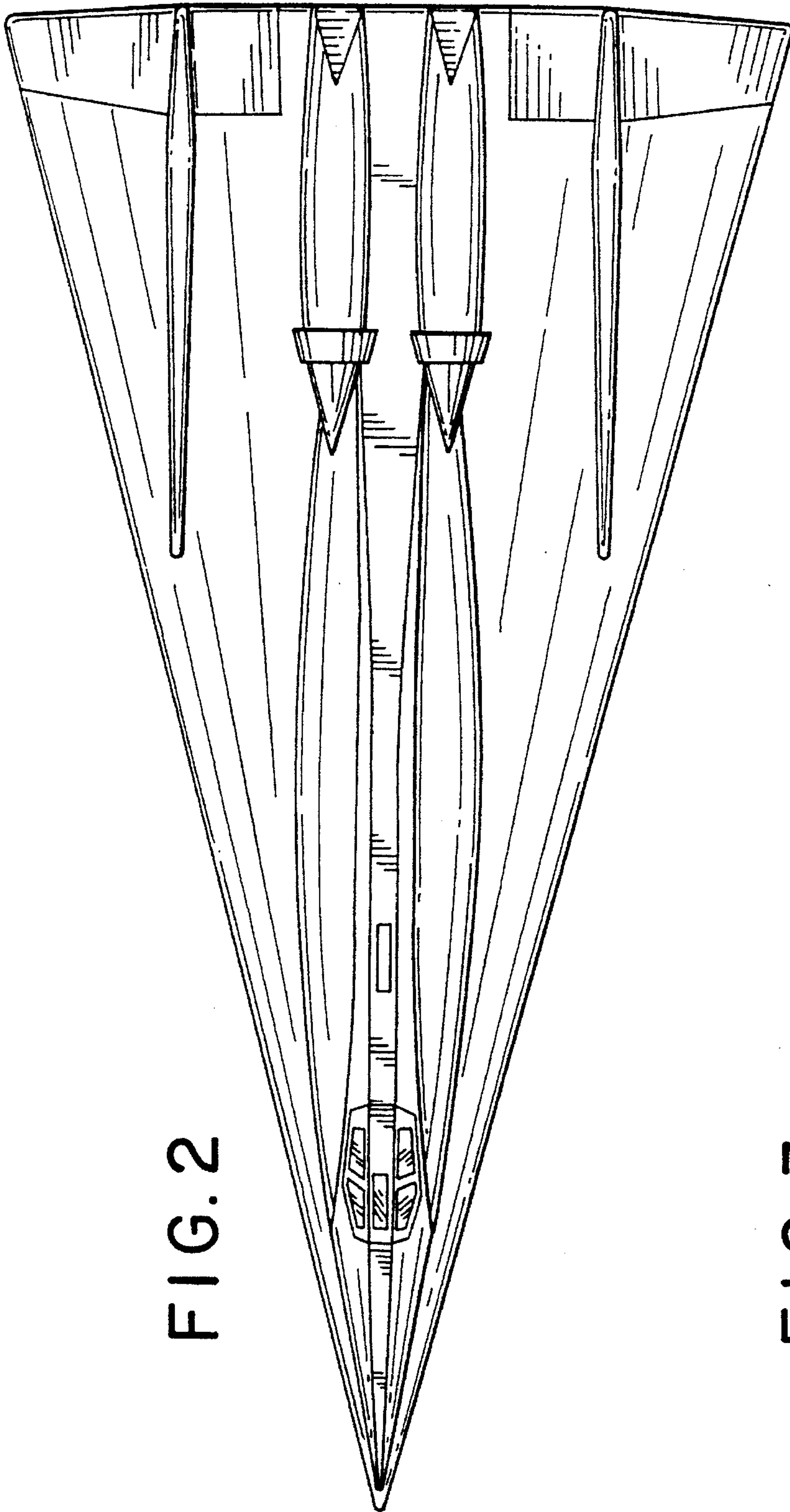

FIG. 2

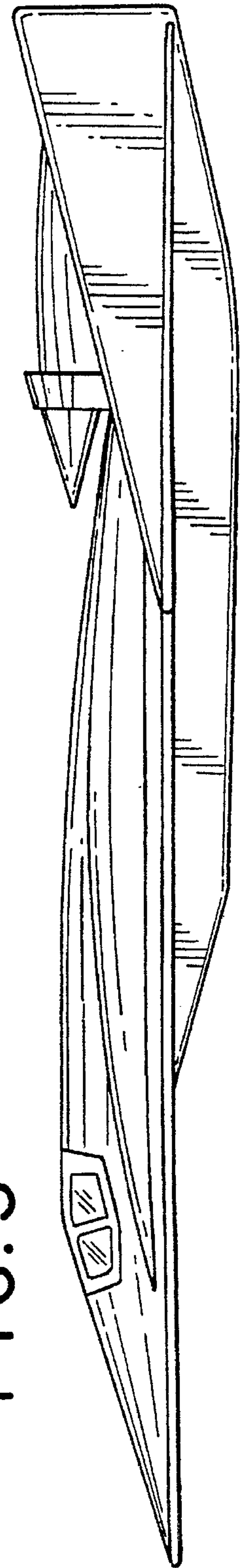

FIG. 3

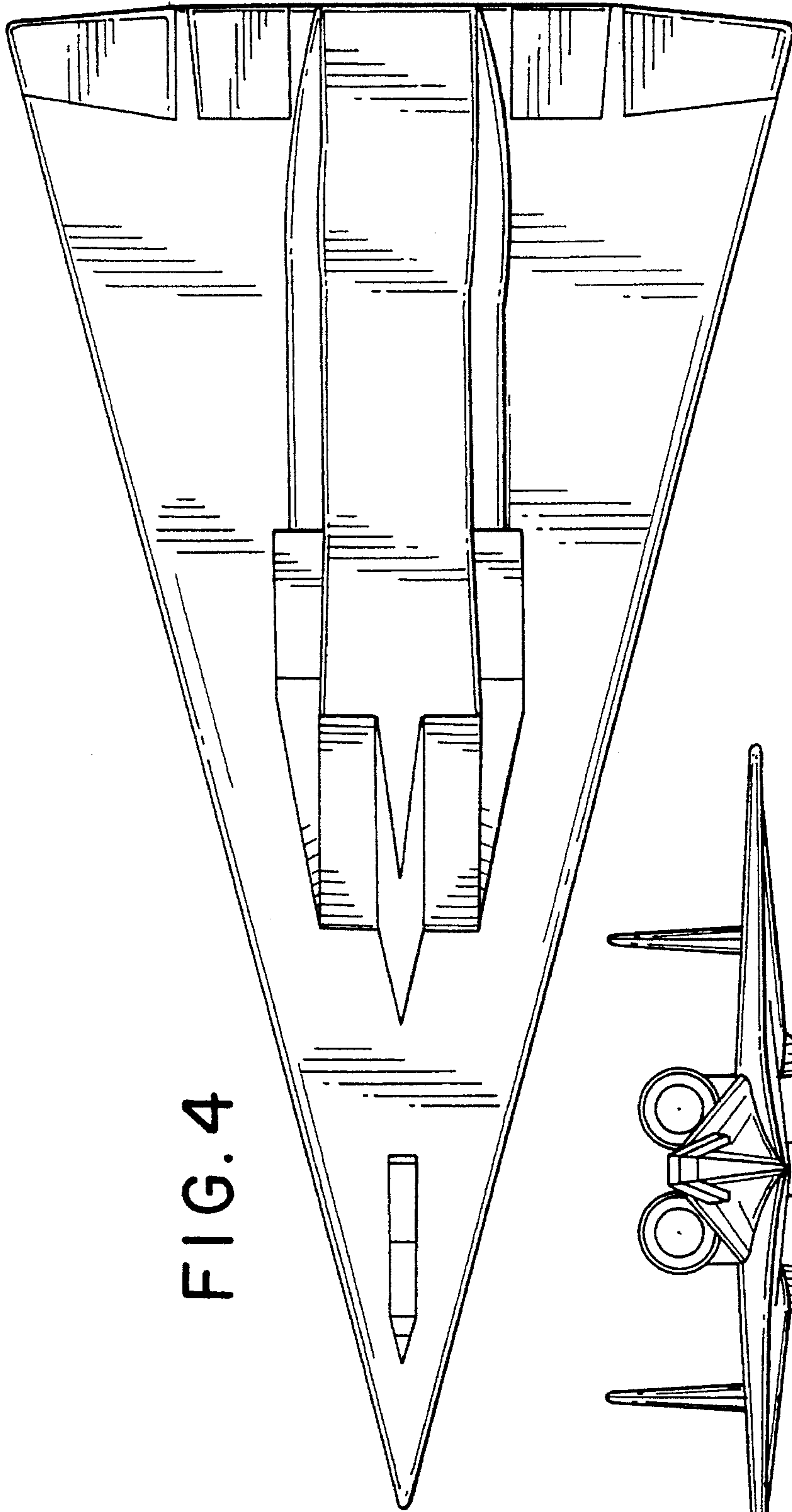

FIG. 4

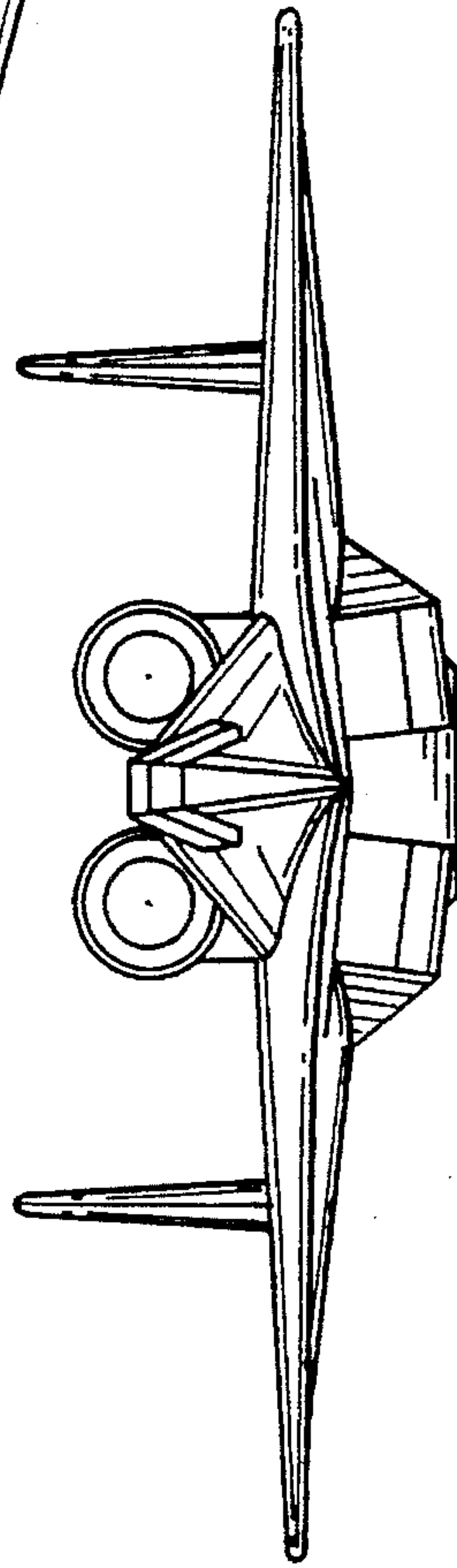

FIG. 5

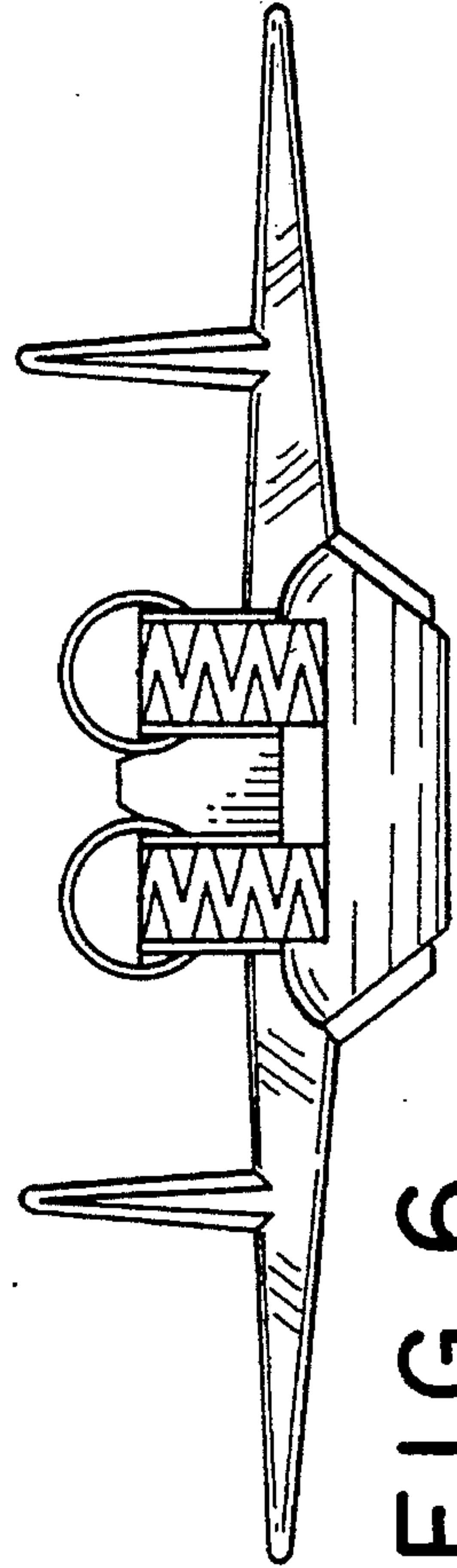

FIG. 6