



US00D364590S

United States Patent [19]

Yamashita

[11] **Patent Number: Des. 364,590**

[45] **Date of Patent: **Nov. 28, 1995**

[54] **UTILITY VEHICLE**

D. 312,227 11/1990 Miyamoto et al. D12/14
D. 337,747 7/1993 Henklen et al. D12/15

[75] Inventor: **Izumi Yamashita**, Newnan, Ga.

OTHER PUBLICATIONS

[73] Assignee: **Yamaha Motor Manufacturing Corporation of America**, Newnan, Ga.

The Cushman Brochure, Jun. 1989, p. 6, The 4-Wheel Turf Truckster.

[**] Term: **14 Years**

Primary Examiner—A. Hugo Word
Assistant Examiner—M. Brown
Attorney, Agent, or Firm—Saidman DesignLaw Group

[21] Appl. No.: **22,756**

[57] CLAIM

[22] Filed: **May 11, 1994**

[52] U.S. Cl. **D12/15**; D12/14

The ornamental design for a utility vehicle, as shown and described.

[58] Field of Search D12/14, 15, 16,
D12/85; 296/184; 180/22, 24.01, 24.11

DESCRIPTION

[56] References Cited

FIG. 1 is a left side elevation view of a utility vehicle showing my new design;
FIG. 2 is a right side elevation view thereof;
FIG. 3 is a front elevation view thereof;
FIG. 4 is a rear elevation view thereof; and,
FIG. 5 is a top plan view thereof.

U.S. PATENT DOCUMENTS

D. 269,077	5/1983	Horton	D12/1
D. 282,153	1/1986	Wallace et al.	D12/14
D. 292,899	11/1987	Samuelson et al.	D12/15
D. 310,342	9/1990	Formoss	D12/14
D. 311,505	10/1990	Reinhart	D12/14

1 Claim, 2 Drawing Sheets

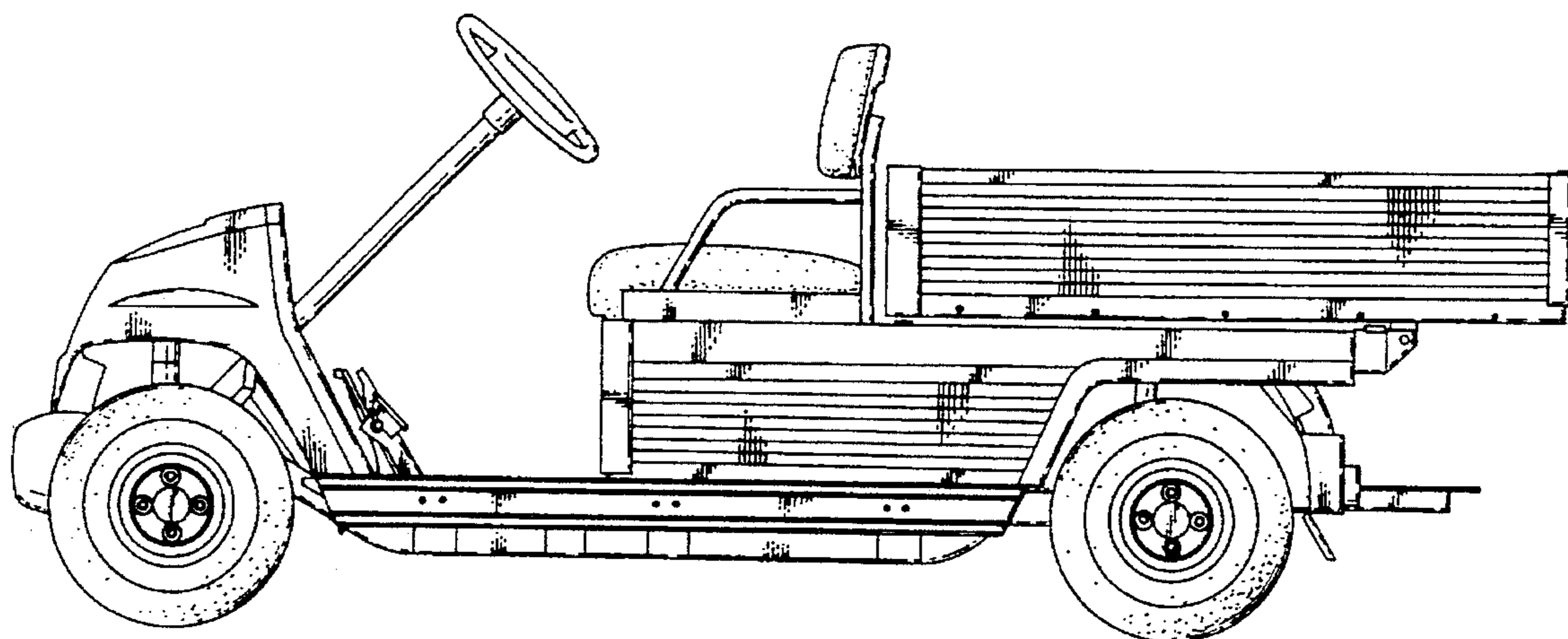

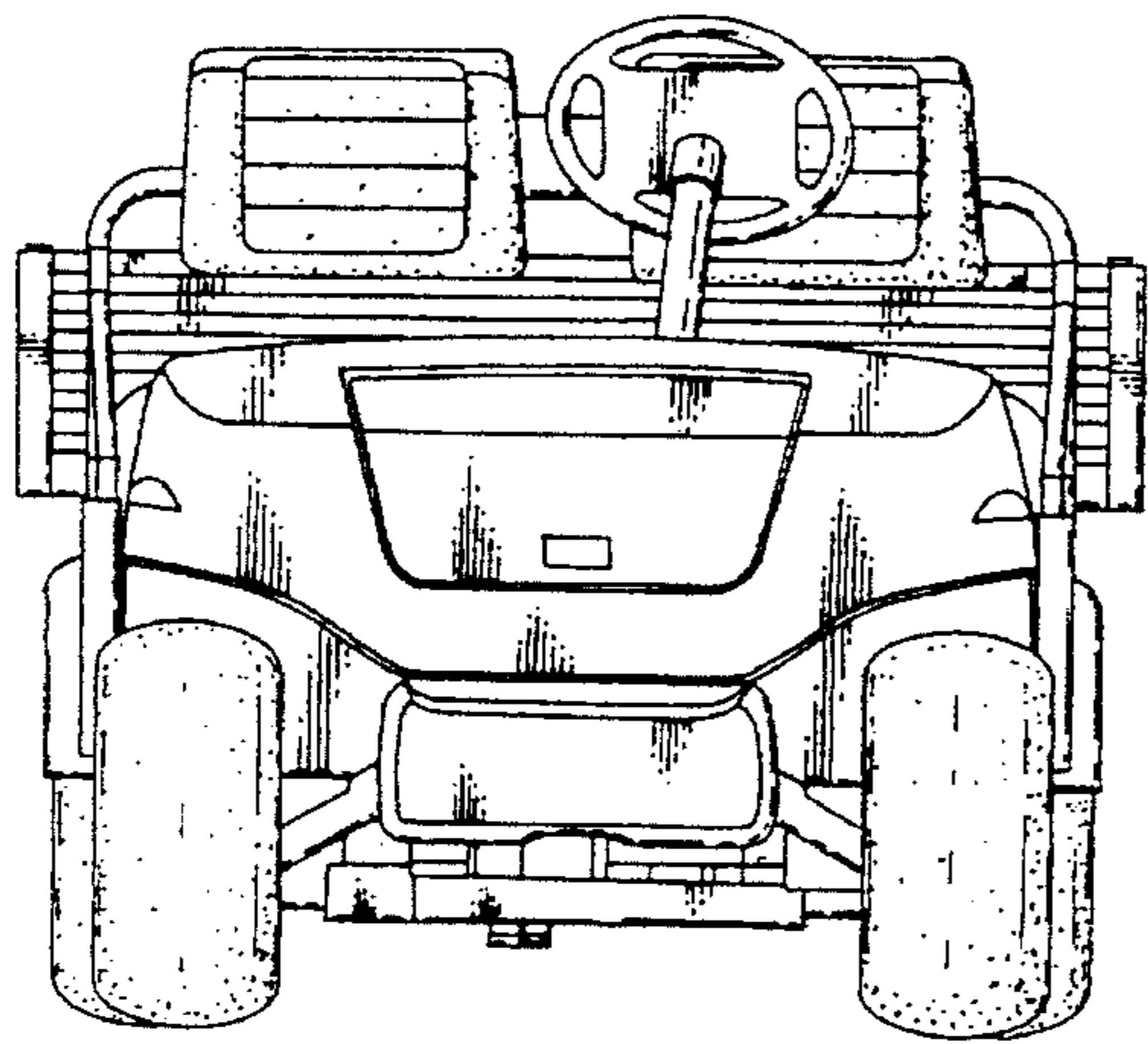

FIG. 3

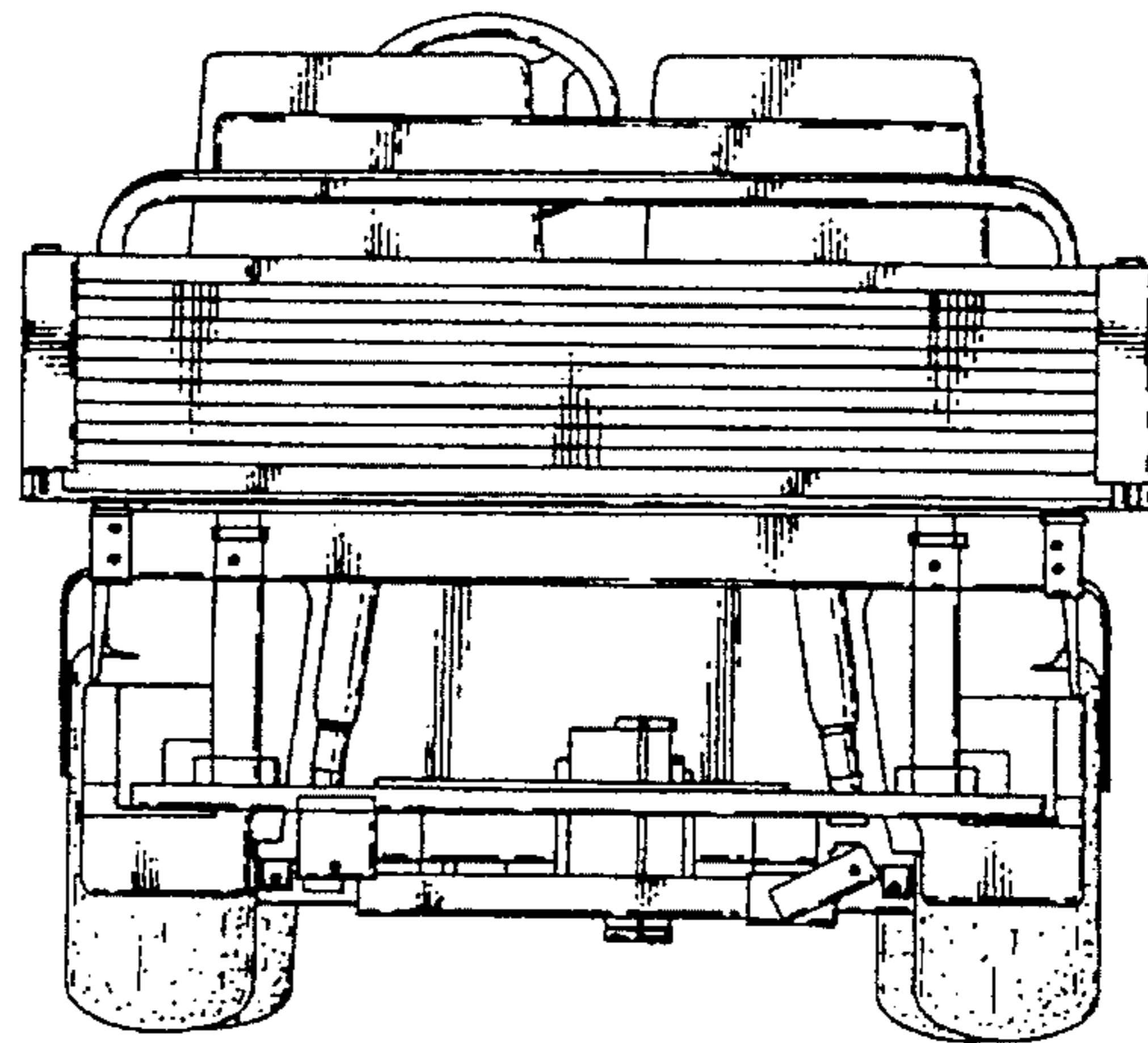

FIG. 4

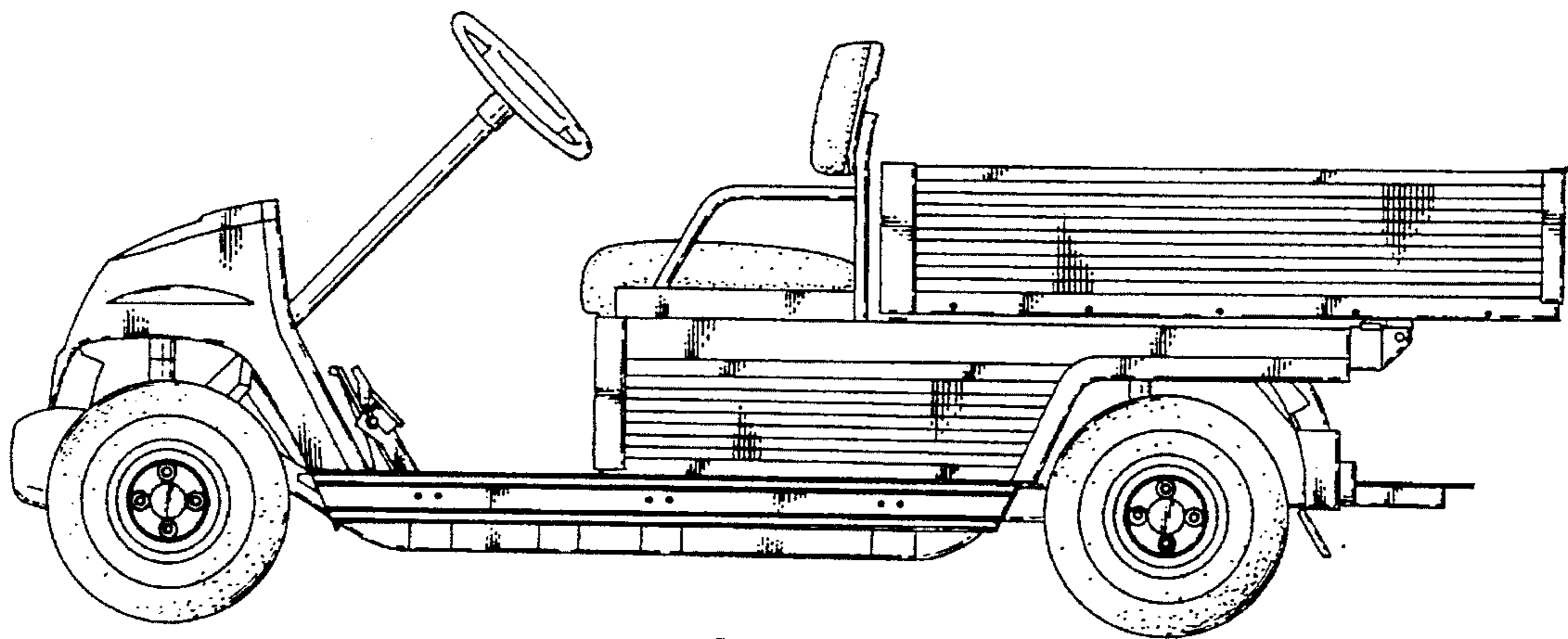

FIG. 1

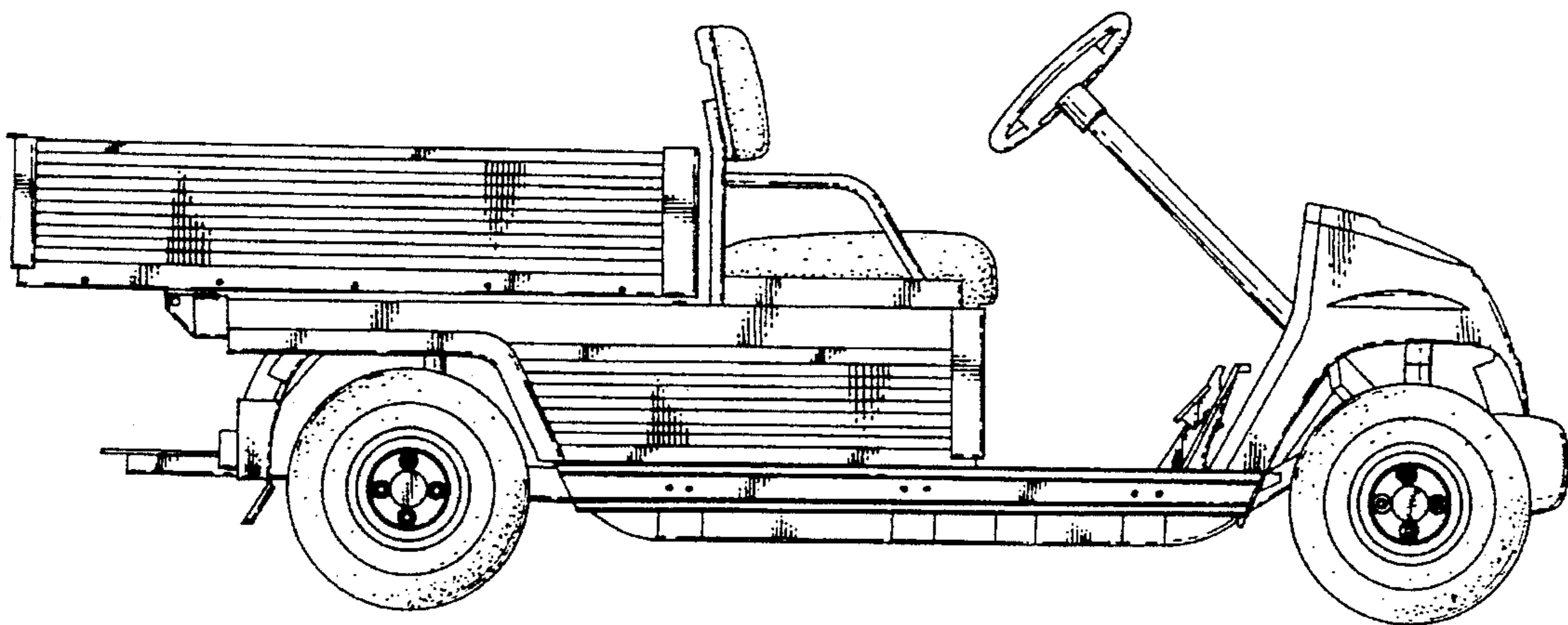

FIG. 2

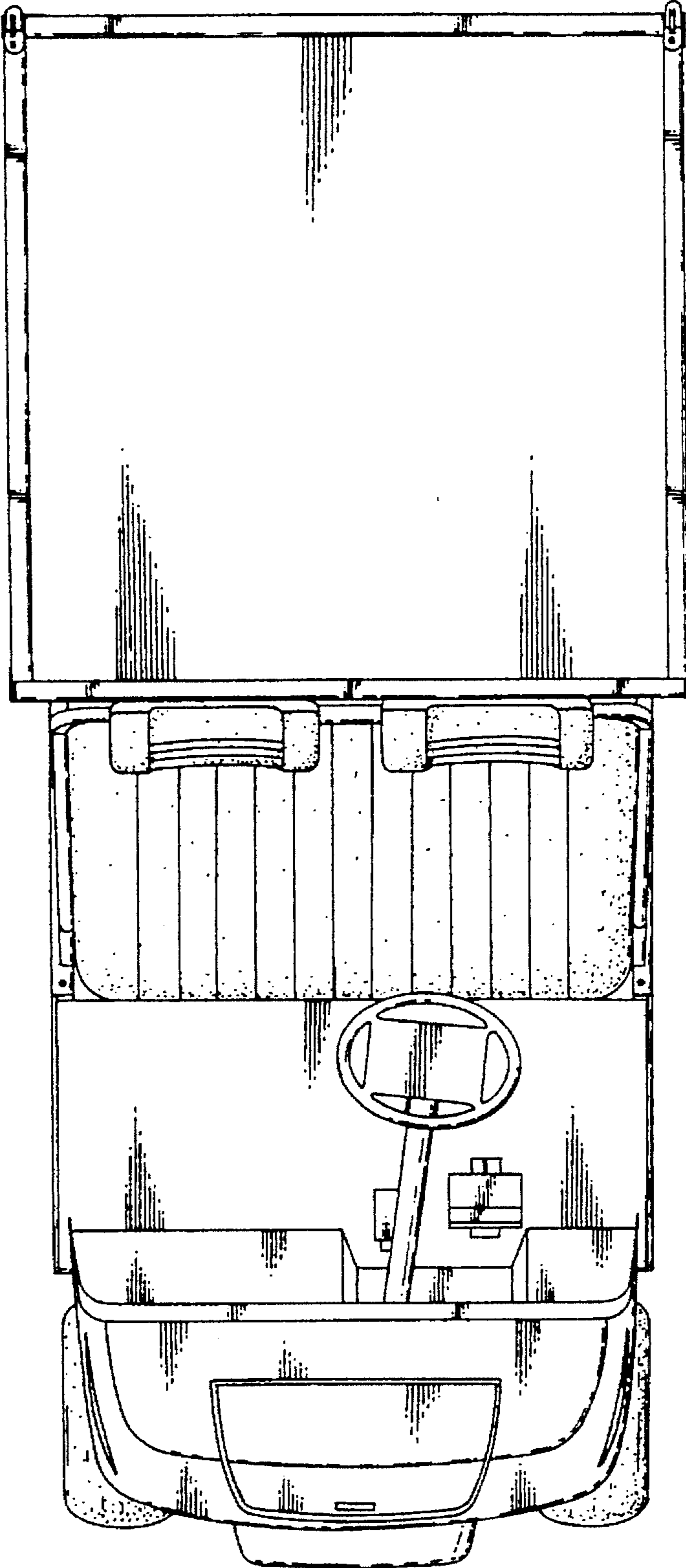

FIG. 5