



US00D364575S

United States Patent [19]
Goldner

[11] **Patent Number: Des. 364,575**
[45] **Date of Patent: **Nov. 28, 1995**

[54] **RETRACTABLE TAPE MEASURE**
[76] Inventor: **Sandor Goldner**, 1251 46th St.,
Brooklyn, N.Y. 11219
[**] Term: **14 Years**
[21] Appl. No.: **26,131**
[22] Filed: **Jan. 31, 1992**
[52] U.S. Cl. **D10/72**
[58] Field of Search **D10/72; 33/761,**
33/767, 770; 242/381.3, 384.7

4,748,746 6/1988 Jacoff 33/761
4,938,430 7/1990 Chapin 242/107.2

Primary Examiner—Antoine Duval Davis
Attorney, Agent, or Firm—Fitzpatrick, Cella, Harper &
Scinto

[57] **CLAIM**

The ornamental design for a retractable tape measure, as shown and described.

DESCRIPTION

FIG. 1 is a front side elevational view of the retractable tape measure showing my design;
FIG. 2 is a rear side elevational view;
FIG. 3 is a top plan view;
FIG. 4 is a front end view;
FIG. 5 is a rear end view; and,
FIG. 6 is a bottom view.

1 Claim, 2 Drawing Sheets

[56] **References Cited**

U.S. PATENT DOCUMENTS

D. 211,054 5/1968 Heuer D10/72
D. 318,815 8/1991 Chapin D10/72
3,577,641 5/1971 Smith D10/72
4,153,996 5/1979 Ritty 33/767

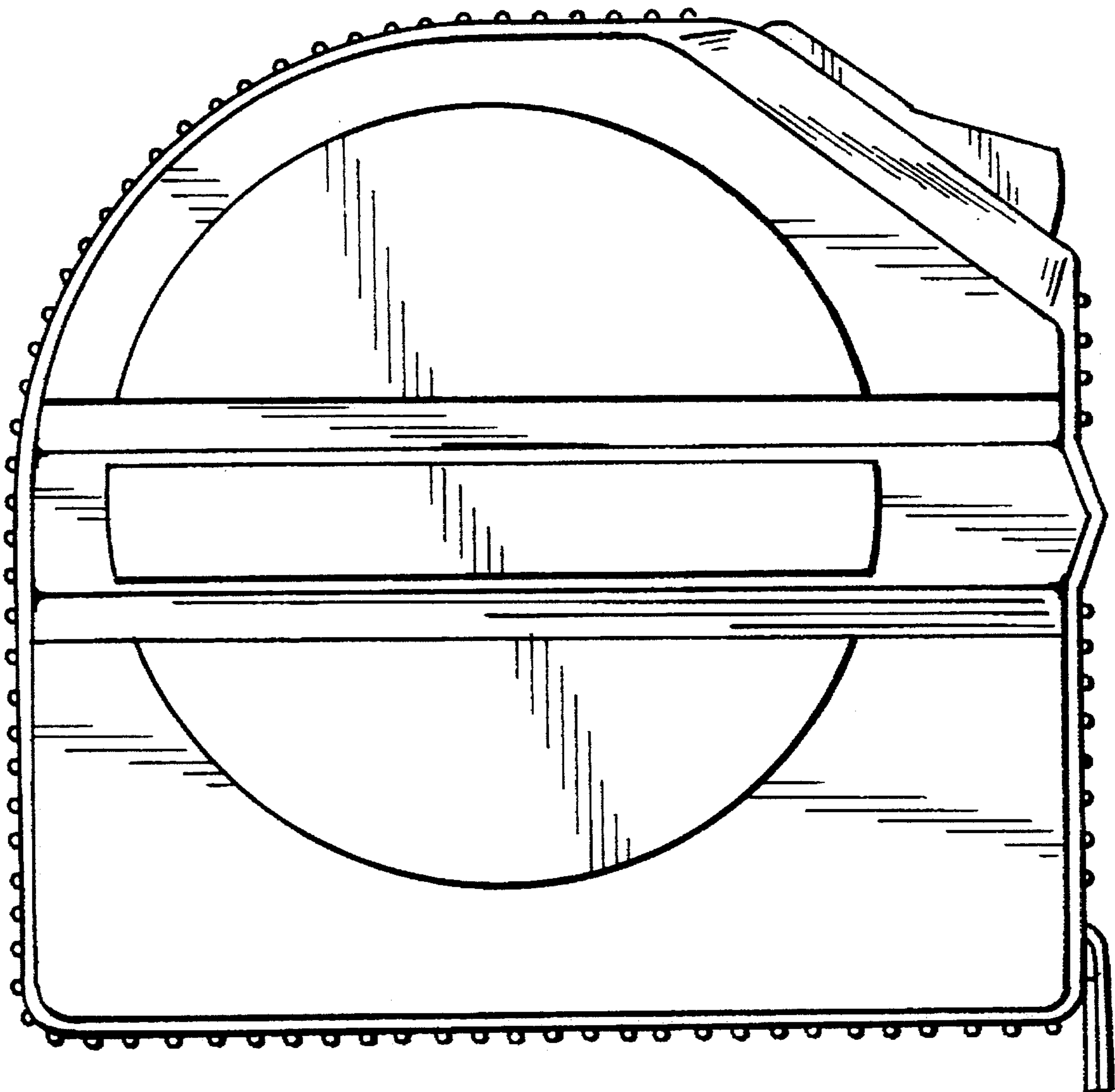

FIG. 1

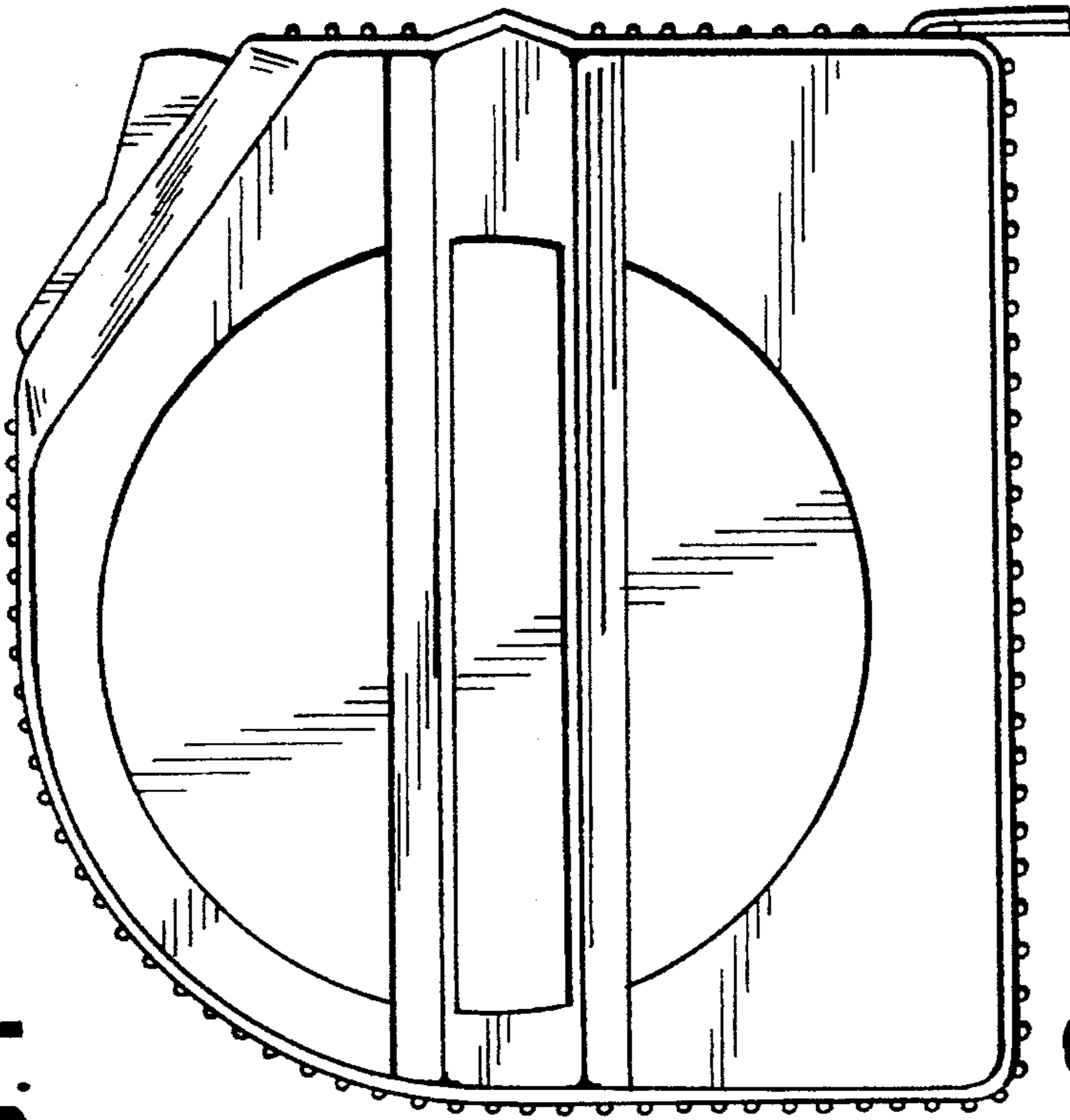

FIG. 3

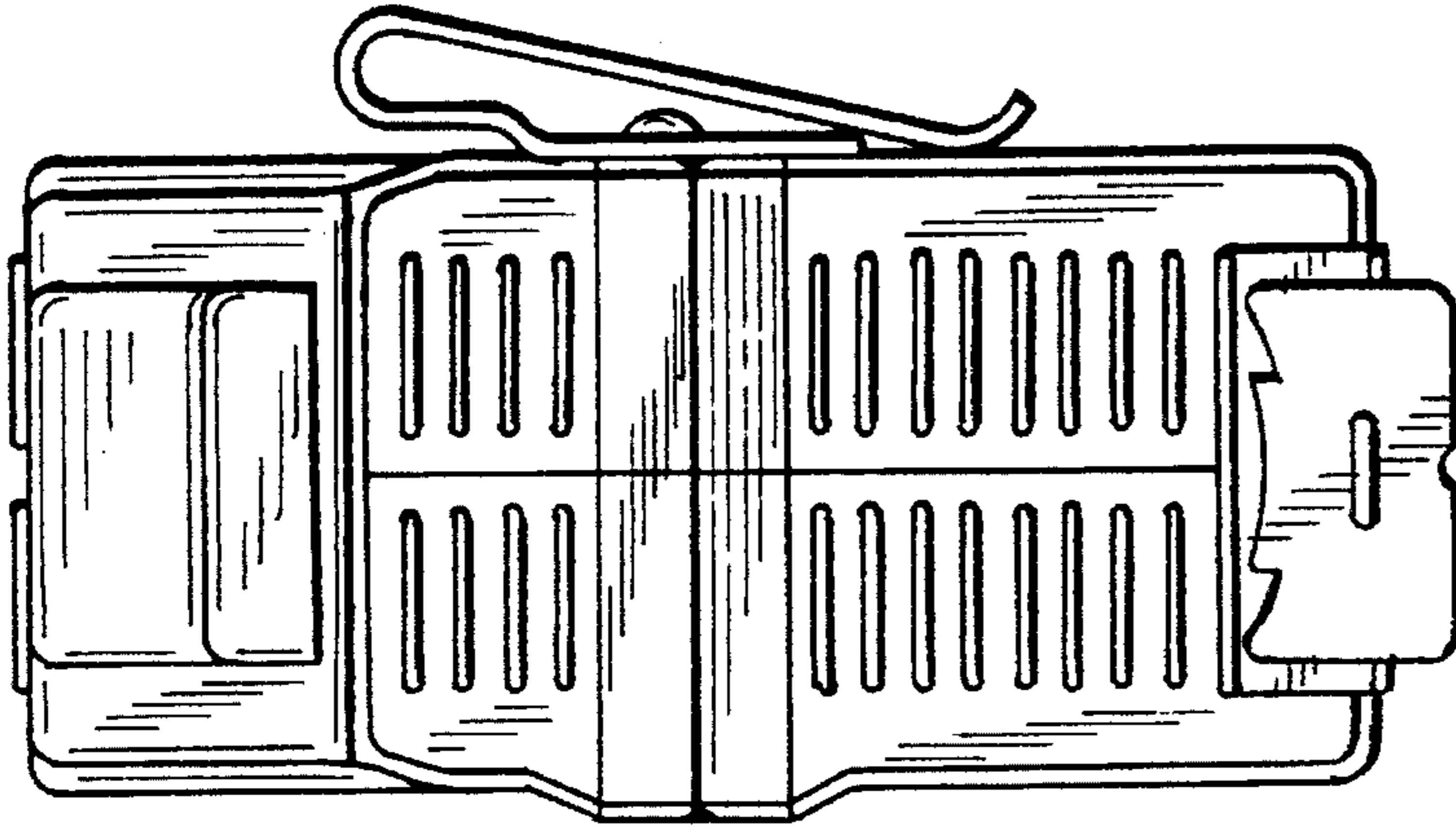
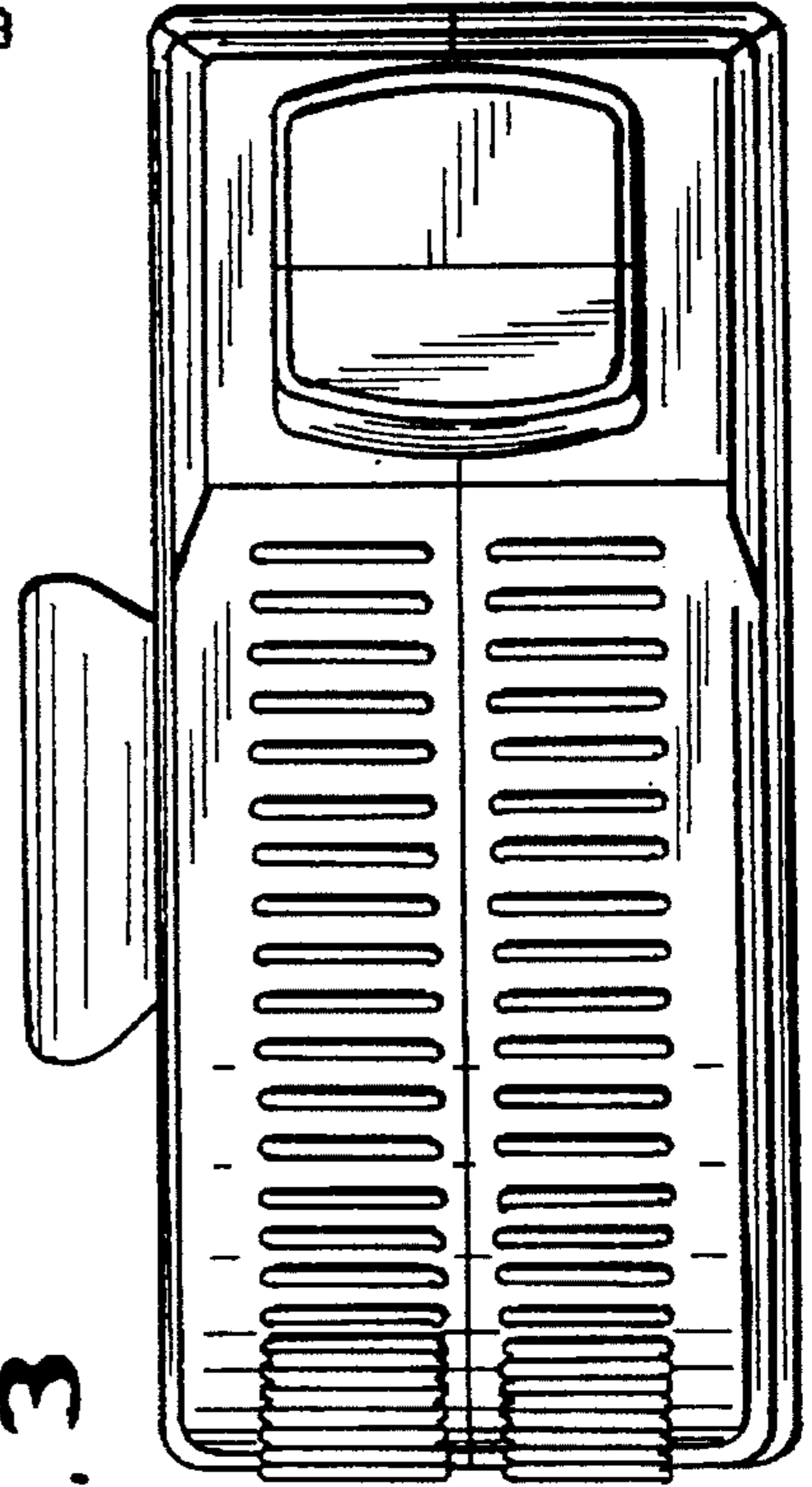

FIG. 4

FIG. 2

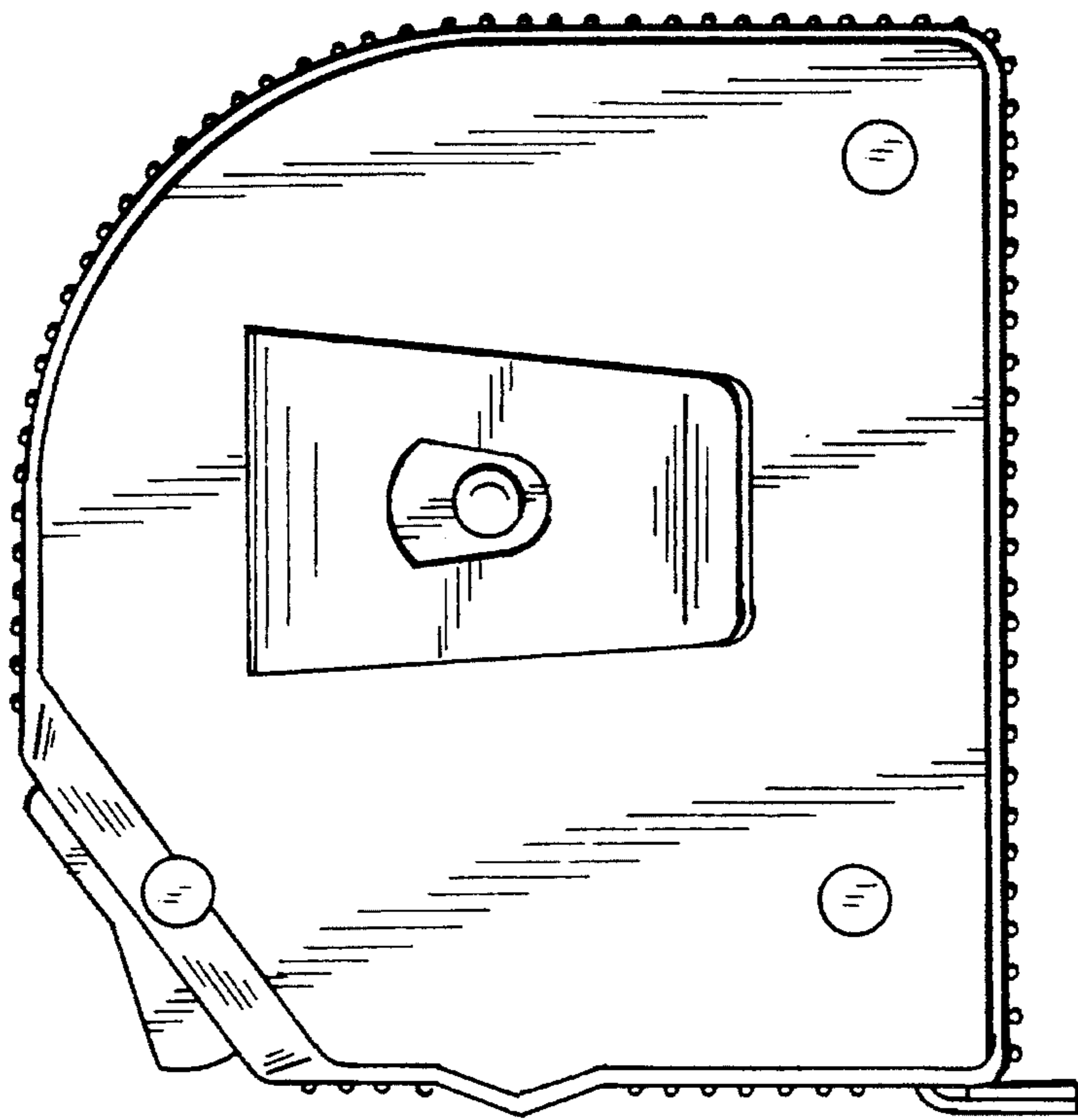

FIG. 6

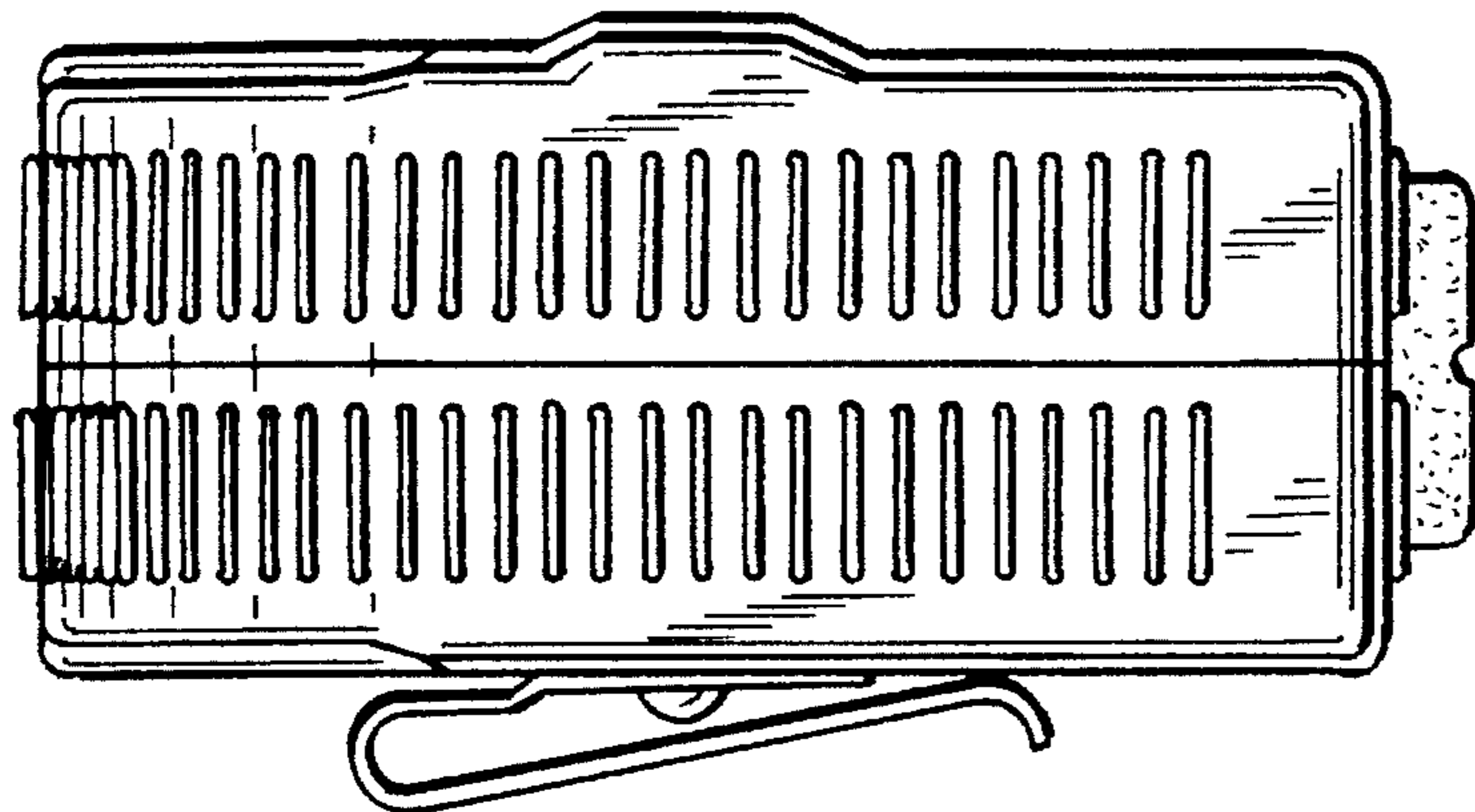
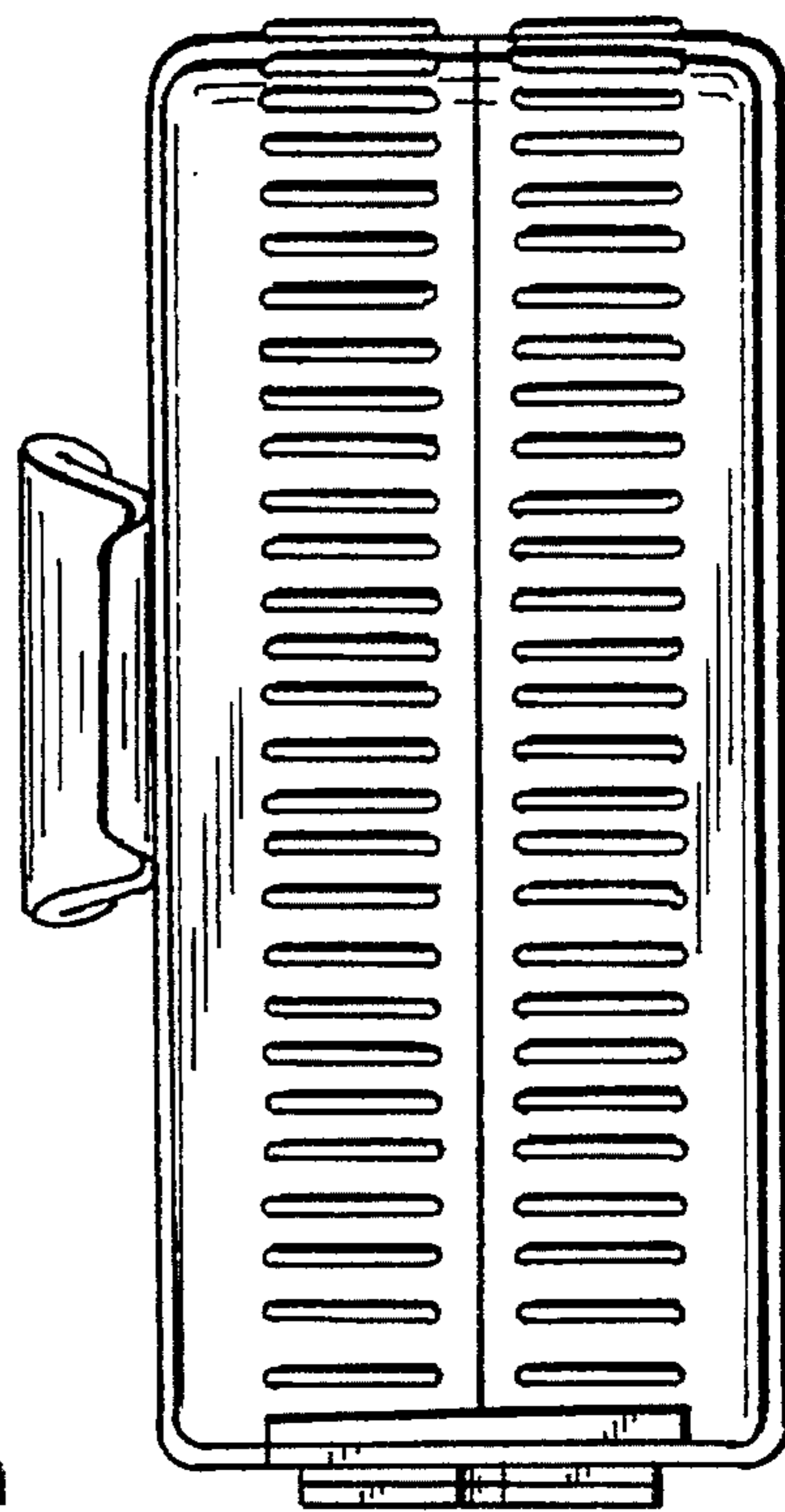

FIG. 5