



US00D364371S

United States Patent [19]

Ray et al.

[11] Patent Number: **Des. 364,371**

[45] Date of Patent: ****Nov. 21, 1995**

[54] TRUCK BUMPER

[75] Inventors: **Robert A. Ray**, Highland Village, Tex.;
Ronaldo S. Natividad, San Jose, Calif.

[73] Assignee: **Paccar Inc.**, Bellevue, Wash.

[**] Term: **14 Years**

[21] Appl. No.: **28,502**

[22] Filed: **Sep. 16, 1994**

[52] U.S. Cl. **D12/169**

[58] Field of Search D12/96, 167, 169,
D12/181; 293/102, 117, 120; 296/180.1,
180.2

[56] References Cited

U.S. PATENT DOCUMENTS

D. 302,257	7/1989	Breitschwerdt et al.	D12/96
D. 307,254	4/1990	Koske et al. .	
D. 307,567	5/1990	Fingerele .	
D. 307,878	5/1990	Lechner	D12/96
D. 308,032	5/1990	Kerney et al. .	
D. 312,805	12/1990	Marlowe et al. .	
D. 316,241	4/1991	Ray .	
4,932,716	6/1990	Marlowe et al. .	

OTHER PUBLICATIONS

Commercial Motor, Jan. 1985, p. 17, Bumper on the Ford Six Tonner & Bumper on the Mercedes-Benz 3.5 Tonner.

Primary Examiner—A. Hugo Word

Assistant Examiner—Lavone D. Tabor

Attorney, Agent, or Firm—Flehr, Hohbach, Test, Albritton & Herbert

[57] CLAIM

The ornamental design for a truck bumper, as shown and described.

DESCRIPTION

FIG. 1 is a top perspective view of a truck bumper showing our new design, it being understood that the phantom lines are for illustrative purposes only and form no part of the claimed design;

FIG. 2 is a front elevation view thereof;

FIG. 3 is a side elevation view of with the opposite side being a mirror image thereof;

FIG. 4 is a rear elevation view thereof;

FIG. 5 is a top plan view thereof;

FIG. 6 is a bottom plan view thereof; and,

FIG. 7 is a side elevation view, in cross section, taken along the plan of line 7—7 in FIG. 2.

1 Claim, 2 Drawing Sheets

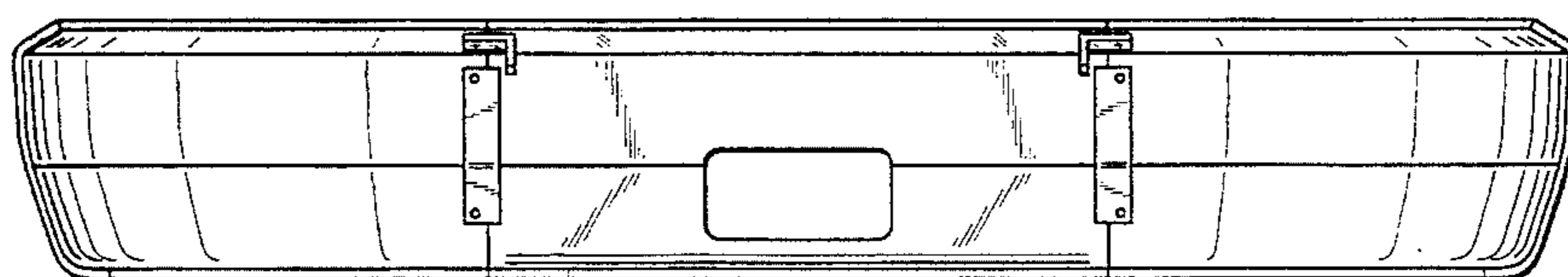
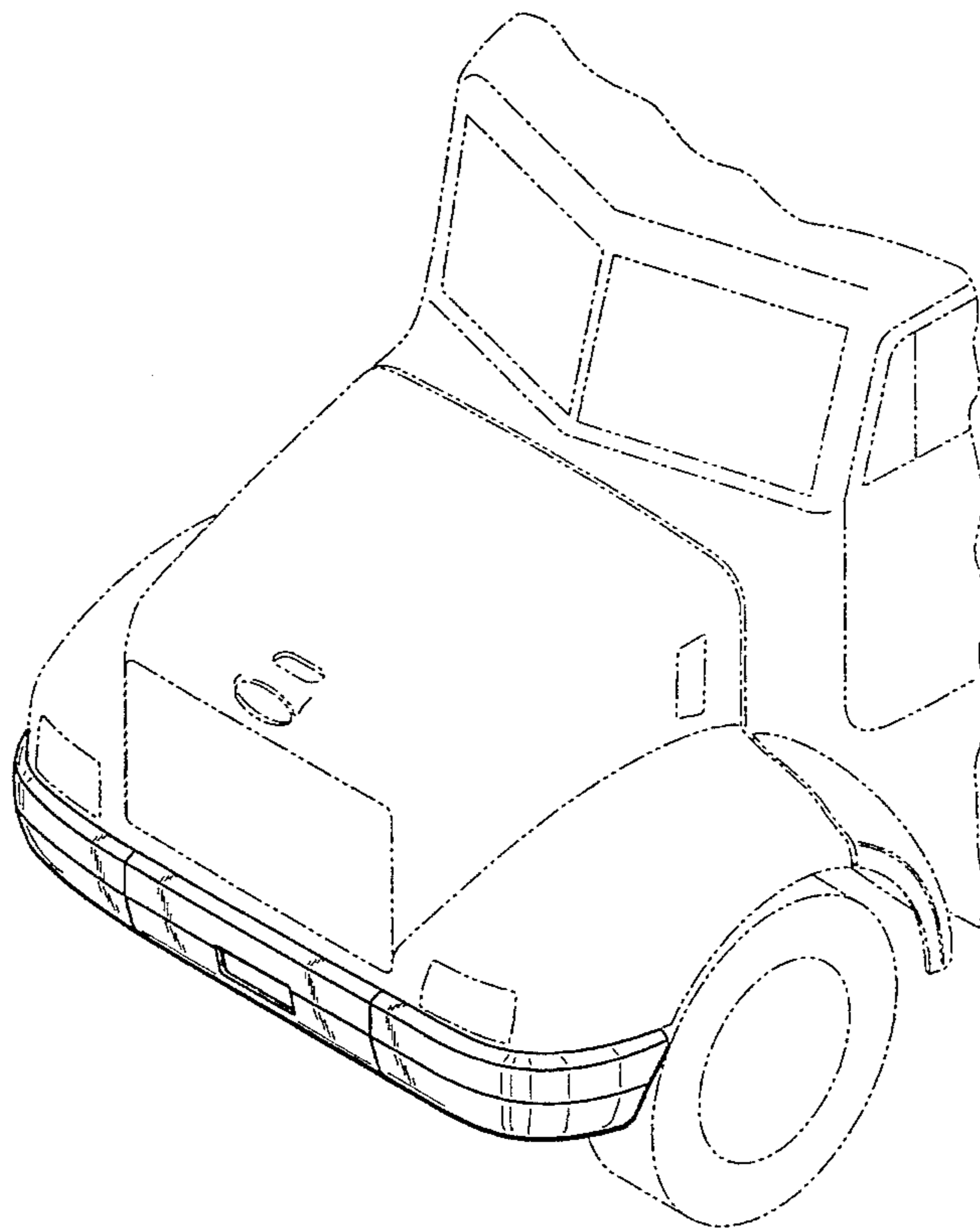

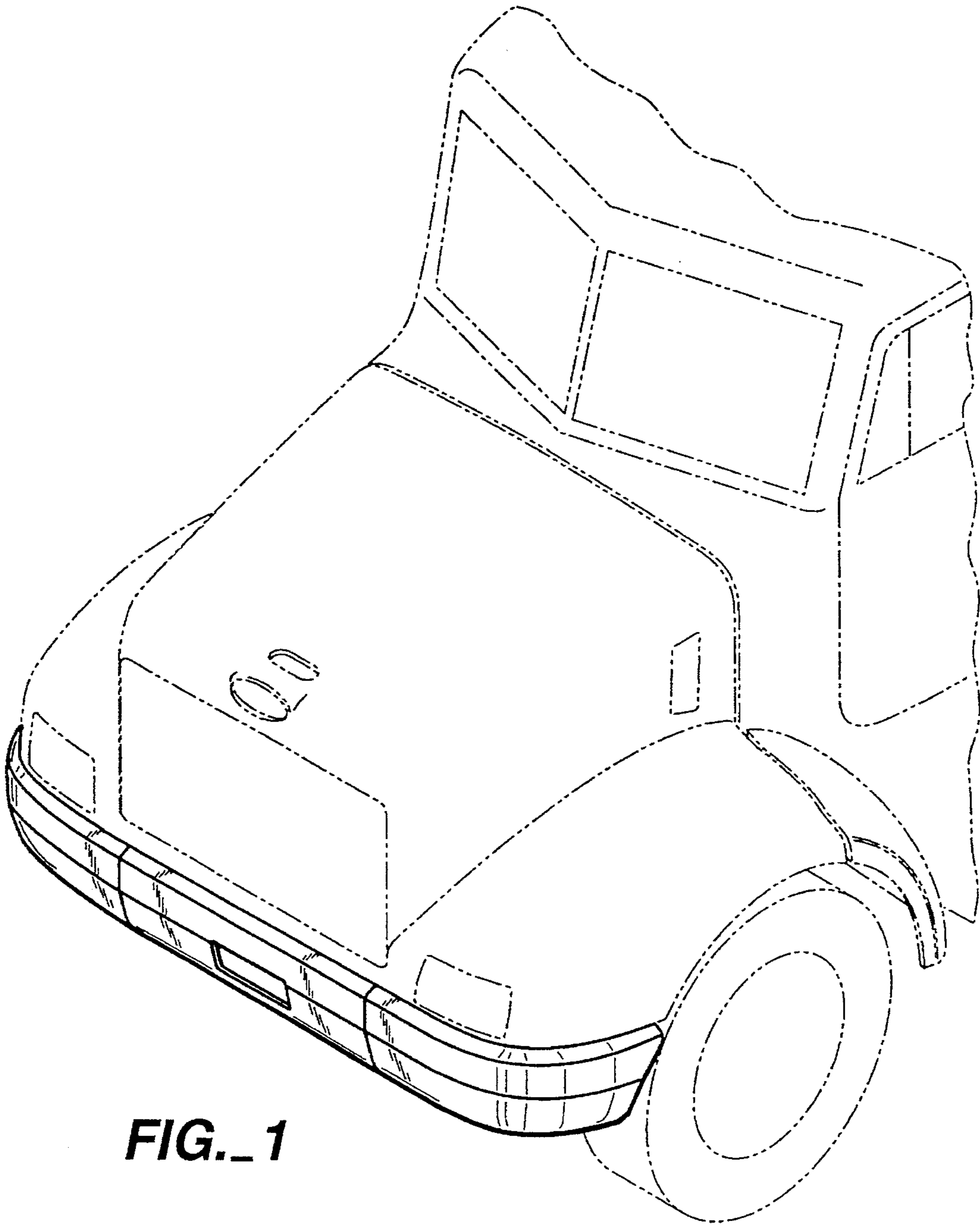

FIG._1

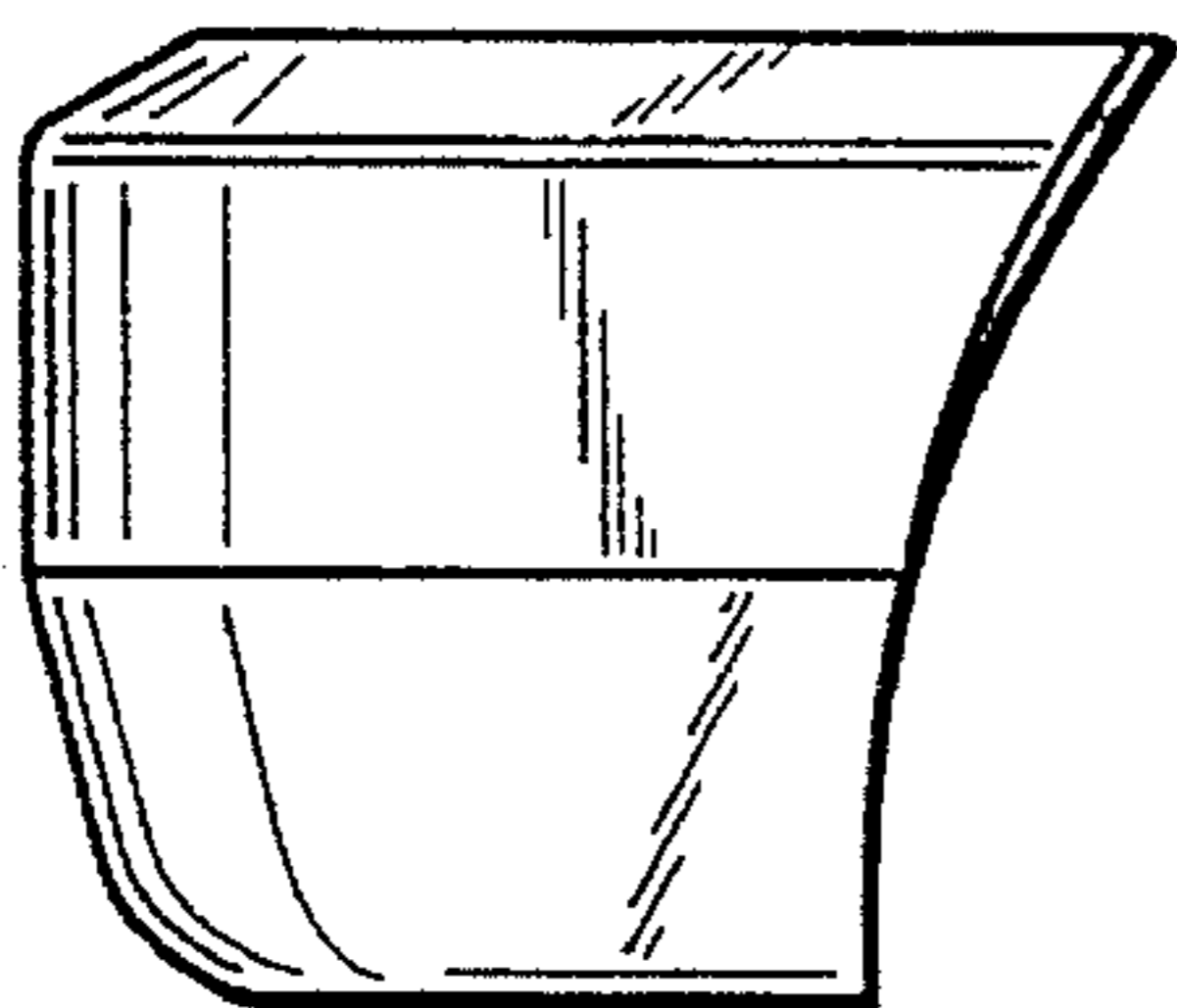

FIG._3

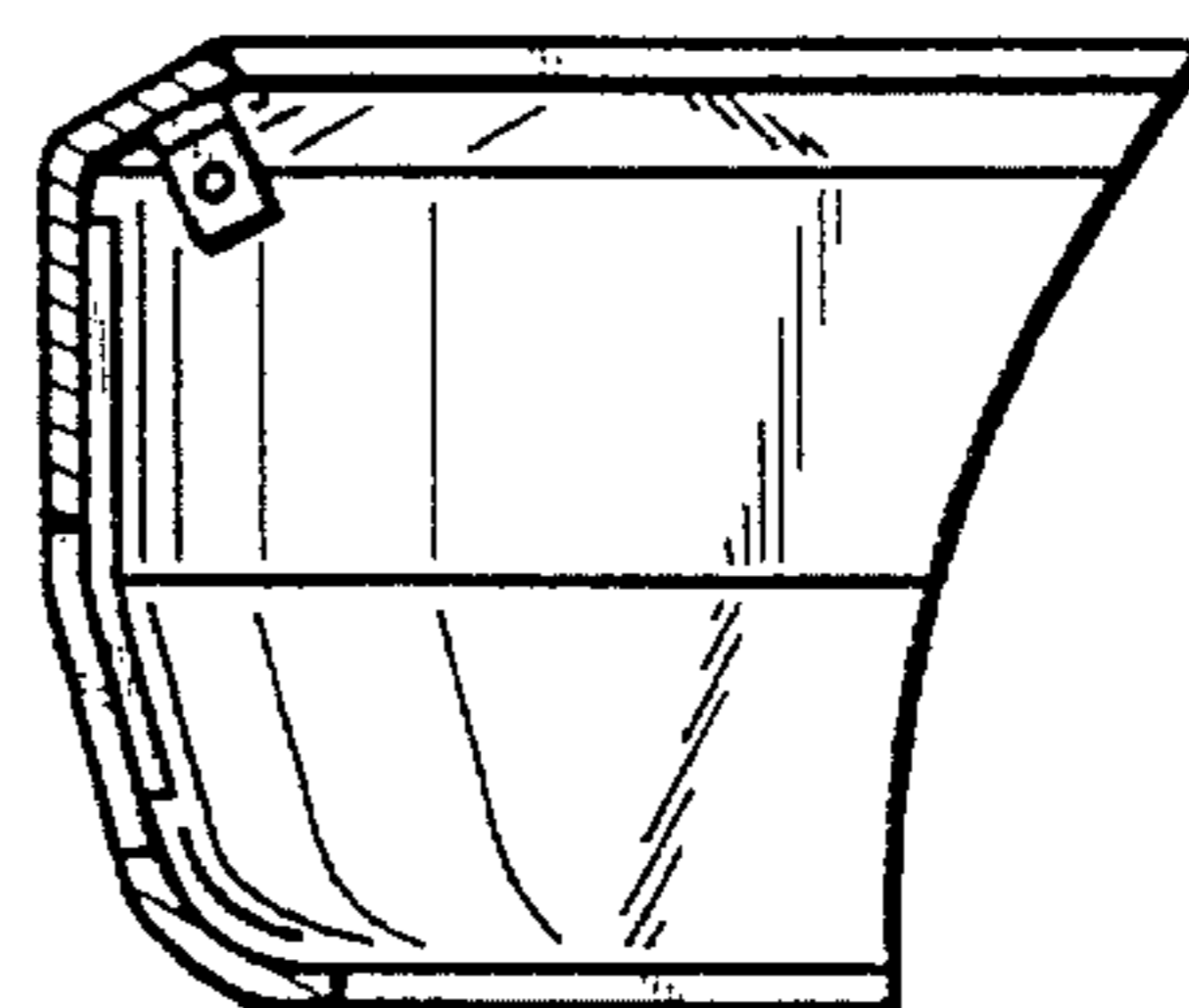

FIG._7

FIG. 2

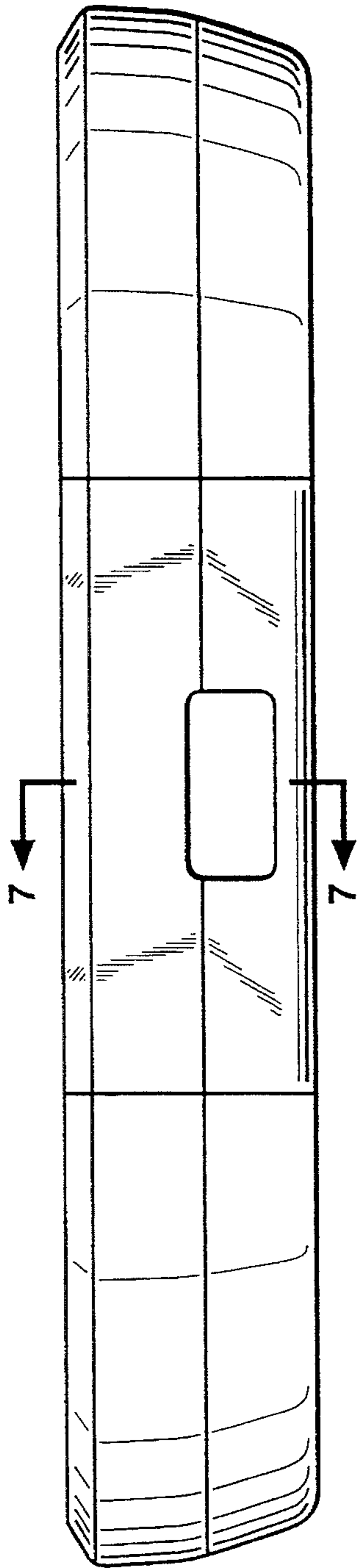

FIG. 4

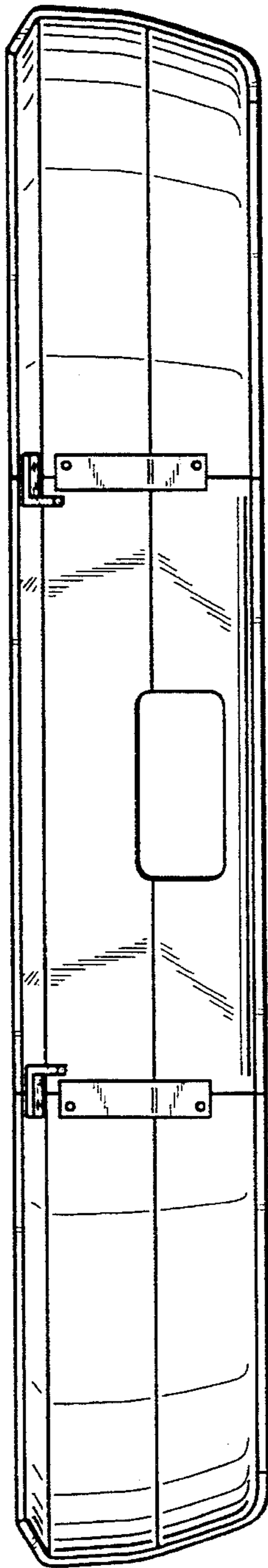

FIG. 5

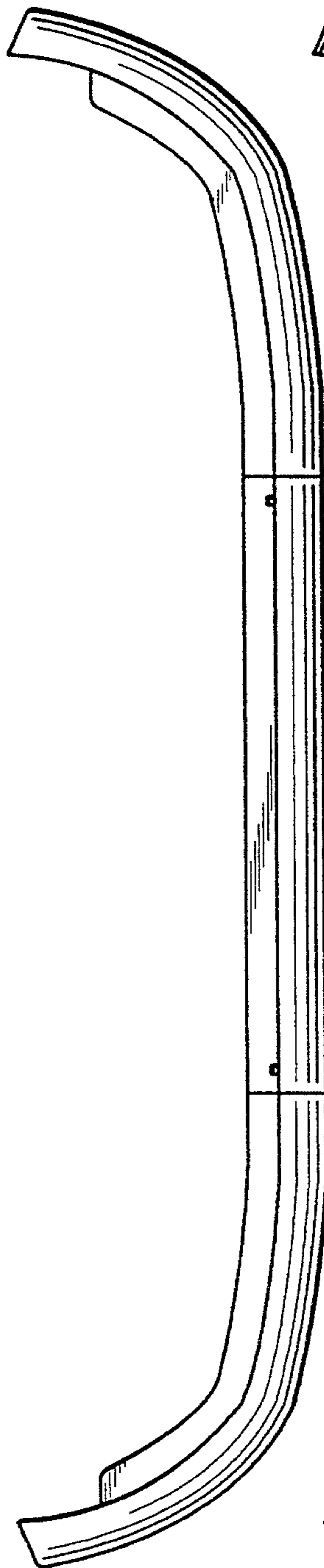

FIG. 6

