



US00D364199S

# United States Patent [19]

Schmidt et al.

[11] Patent Number: **Des. 364,199**

[45] Date of Patent: **\*\*Nov. 14, 1995**

[54] **TOY GEAR WHEEL**  
[75] Inventors: **Sten Schmidt, Grindsted; Kurt Jensen,**  
Vejle, both of Denmark

3,193,293 7/1965 Schaper ..... 446/103  
3,654,726 4/1972 Witte ..... 446/103  
5,194,031 3/1993 Sahler ..... 446/103  
5,259,803 11/1993 Lyman ..... 446/103

[73] Assignee: **Interlego AG,** Baar, Switzerland

*Primary Examiner*—Terry A. Wallace  
*Assistant Examiner*—R. Barkai  
*Attorney, Agent, or Firm*—Kane, Dalsimer, Sullivan,  
Kurucz, Levy, Eisele and Richard

[\*\*] Term: **14 Years**

[21] Appl. No.: **29,151**

### [57] CLAIM

[22] Filed: **Sep. 29, 1994**

The ornamental design for a toy gear wheel, as shown and described.

[52] U.S. Cl. .... **D21/108; D21/141**

[58] Field of Search ..... D21/108, 124,  
D21/128, 132, 134, 141; 446/103, 104,  
121, 128

### DESCRIPTION

FIG. 1 is a top perspective view of the toy gear wheel showing our new design;  
FIG. 2 is a bottom perspective view thereof;  
FIG. 3 is a rear side elevational view thereof;  
FIG. 4 is a side elevational view thereof, all sides being identical; and,  
FIG. 5 is a front elevational view thereof.

### [56] References Cited

#### U.S. PATENT DOCUMENTS

D. 314,995 2/1991 Poulsen et al. .... D21/108  
D. 330,052 10/1992 Klitsner ..... D21/108  
D. 349,736 8/1994 Hatting ..... D21/108  
3,172,666 3/1965 Ryan ..... 446/103

**1 Claim, 2 Drawing Sheets**

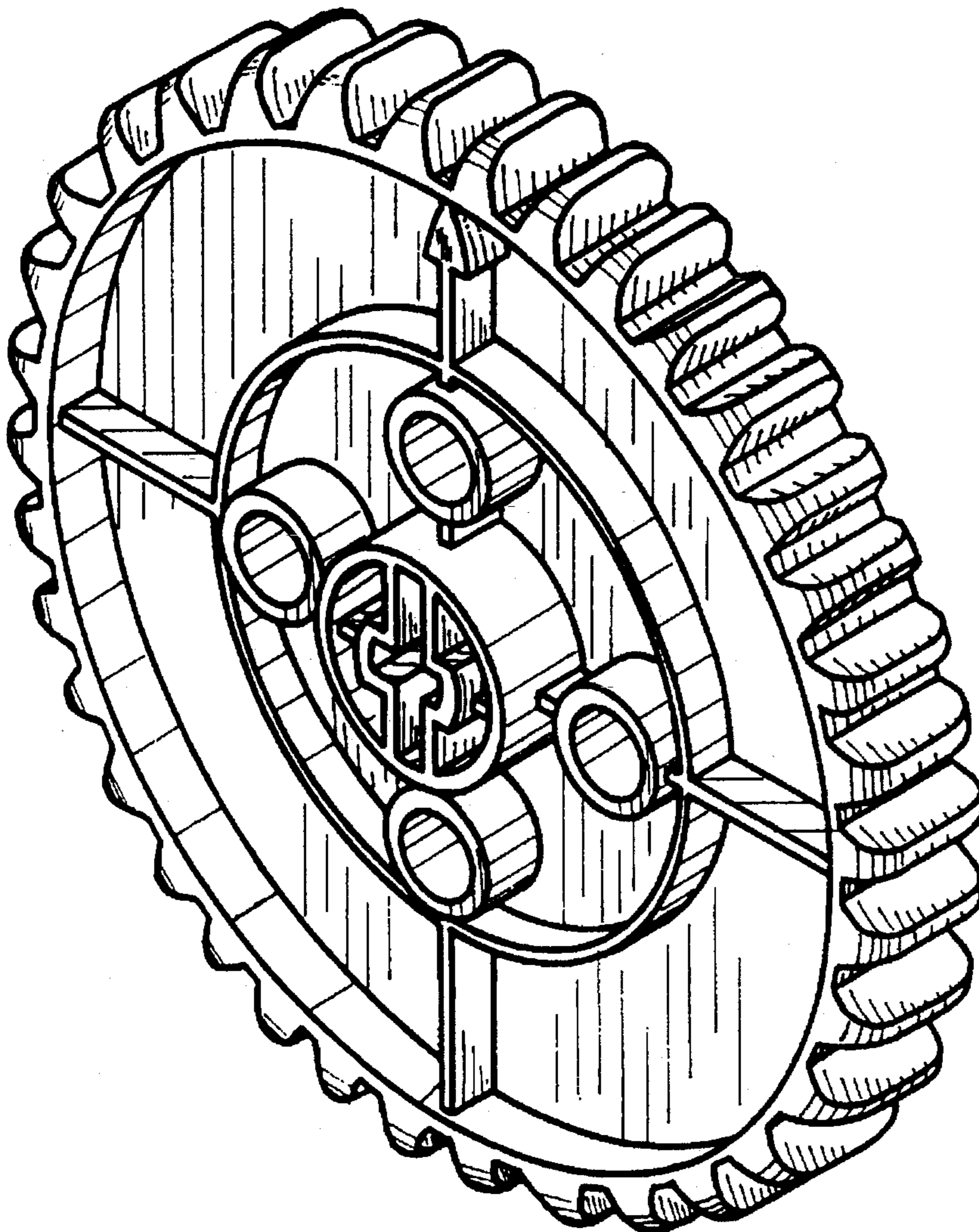

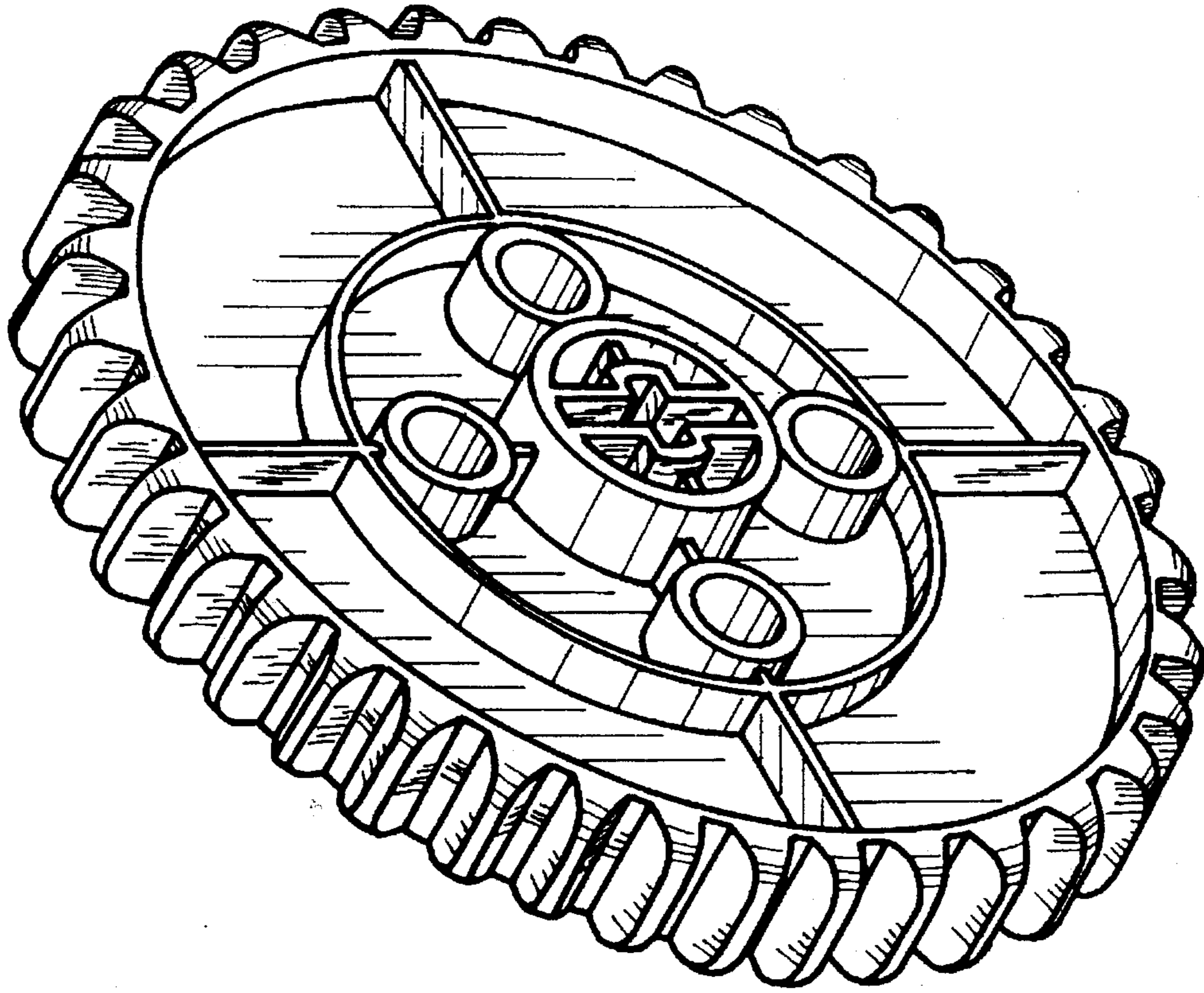

FIG. 2

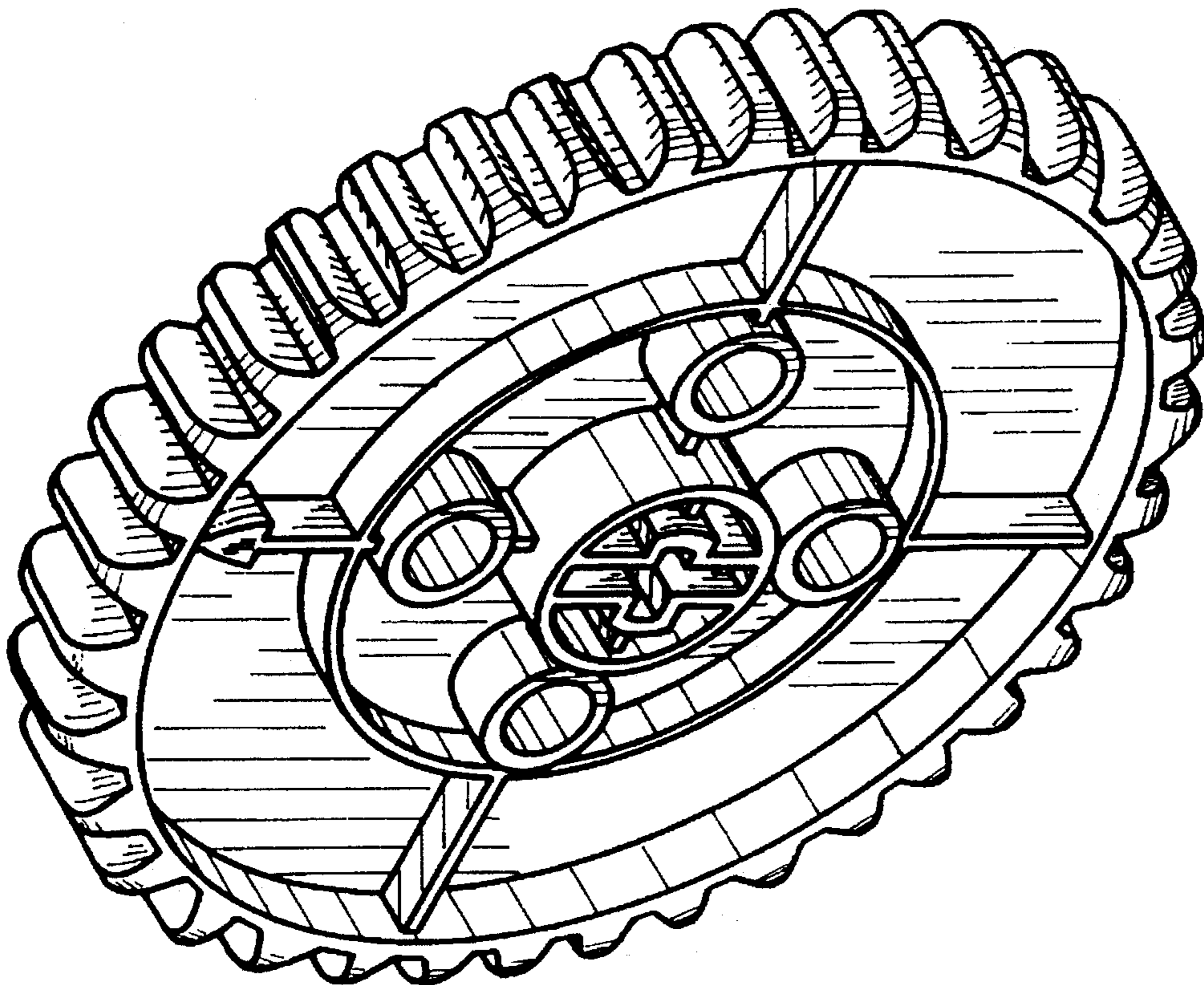

FIG. 1

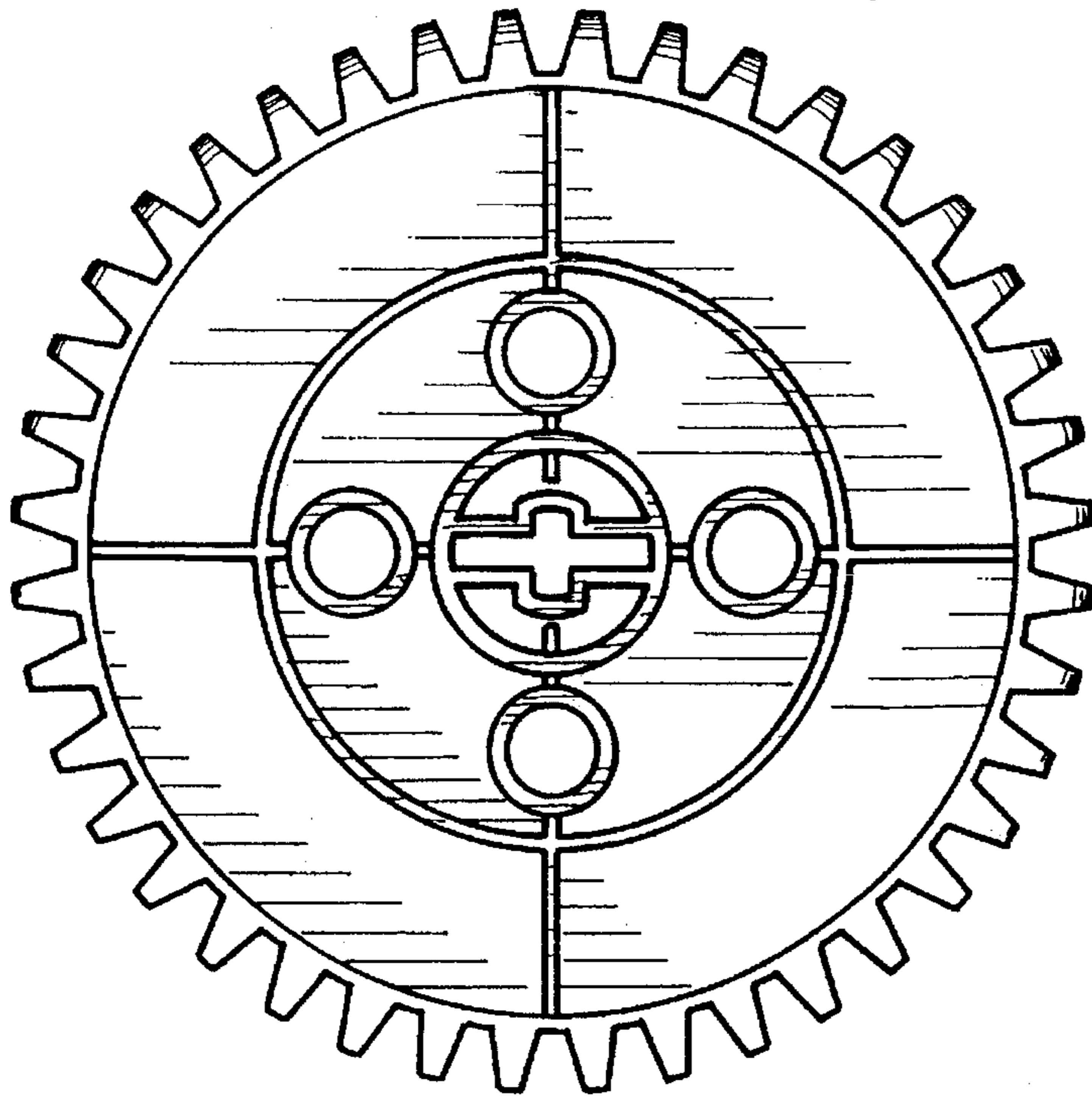

FIG. 3

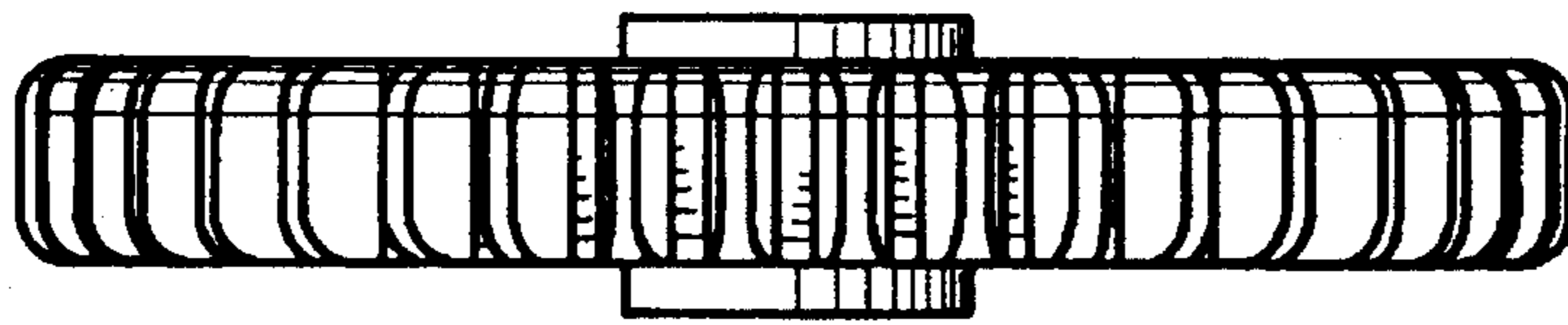

FIG. 4

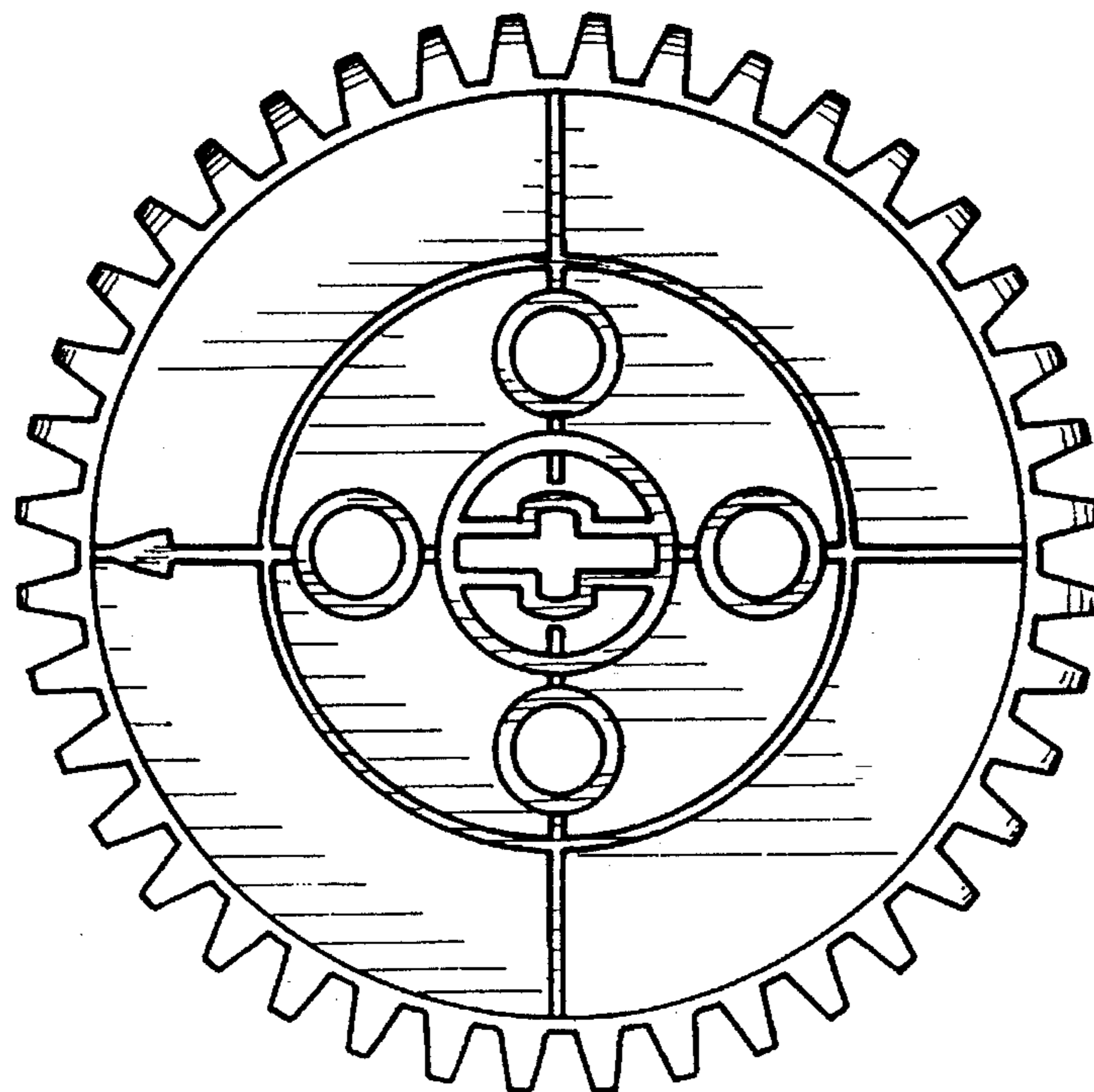

FIG. 5