



US00D364140S

United States Patent [19]
Gustavsen

[11] **Patent Number: Des. 364,140**
[45] **Date of Patent: **Nov. 14, 1995**

[54] **REAR ACCESSORY RACK FOR RECREATIONAL VEHICLE**
[76] Inventor: **Gilbert E. Gustavsen**, 1025 W. Mingus Rd., Phoenix, Ariz. 85027
[**] Term: **14 Years**
[21] Appl. No.: **22,974**
[22] Filed: **May 16, 1994**
[52] U.S. Cl. **D12/407; D12/107**
[58] **Field of Search** D12/407, 408, D12/107, 85; 180/215; 280/288.4, 304.3; 224/32 A, 32 R, 35, 39

4,655,309 4/1987 Imazumi et al. 180/215
4,826,057 5/1989 Yamader 224/42.31

Primary Examiner—A. Hugo Word
Assistant Examiner—M. Brown
Attorney, Agent, or Firm—Martin L. Stoneman

[57] **CLAIM**

The ornamental design for a rear accessory rack for recreational vehicle, as shown and described.

DESCRIPTION

FIG. 1 is perspective view of a rear accessory rack for recreational vehicle showing my new design, it being understood that the broken lines are for illustrative purposes only and form no part of the claimed design.
FIG. 2 is a front elevational view thereof;
FIG. 3 is a rear elevational view thereof;
FIG. 4 is a right side elevational view thereof;
FIG. 5 is a left side elevational view thereof;
FIG. 6 is a top plan view thereof; and,
FIG. 7 is a bottom plan view thereof.

[56] **References Cited**
U.S. PATENT DOCUMENTS

D. 271,389	11/1983	Turkington et al.	D12/407
D. 276,330	11/1984	Stahel	D12/407
D. 289,986	5/1987	Ooba et al.	D12/107
D. 298,811	12/1988	Morita	D12/107
4,176,771	12/1979	Dubror, Sr.	280/304.3
4,247,030	1/1981	Amacker	D12/85

1 Claim, 1 Drawing Sheet

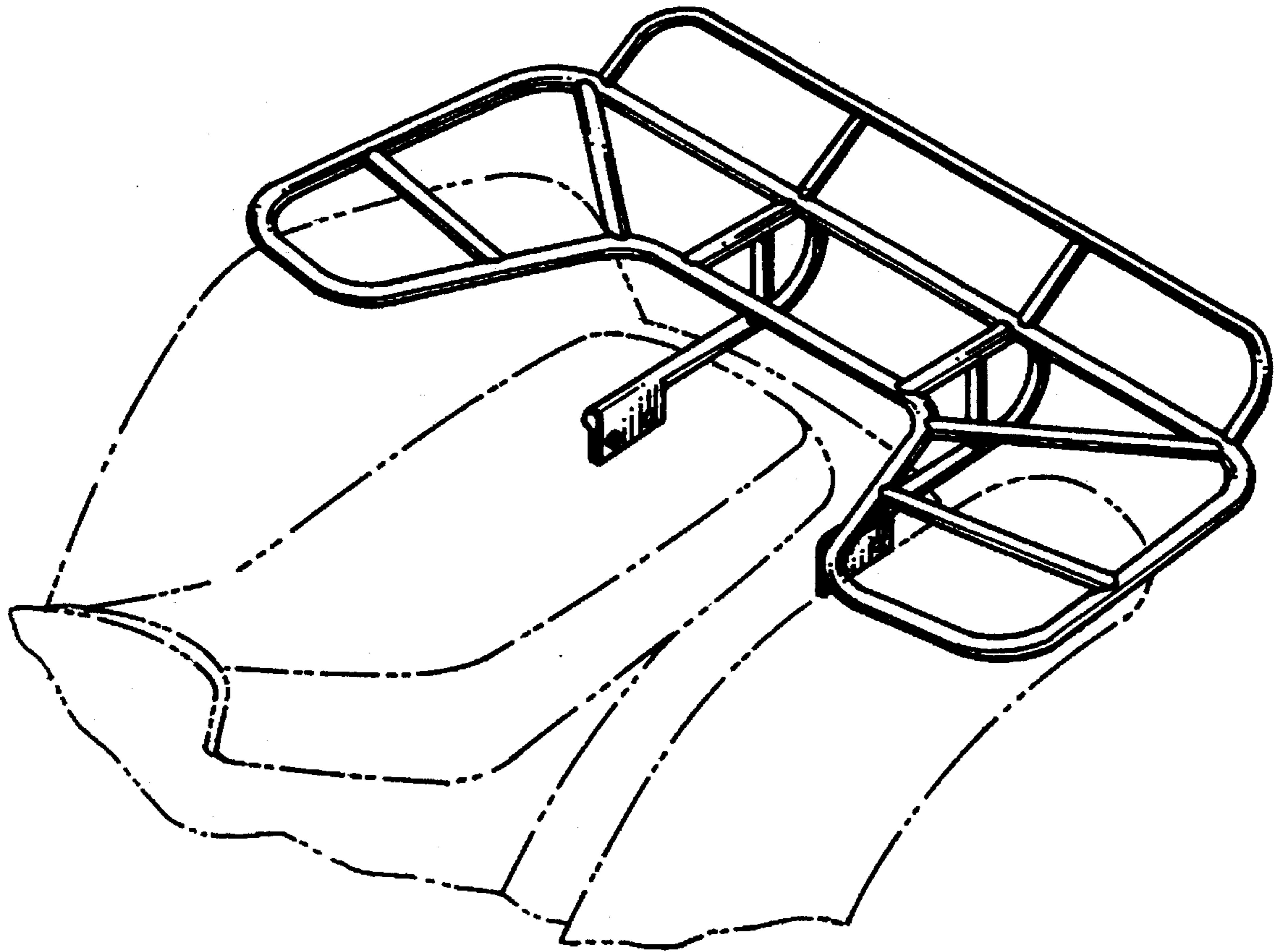

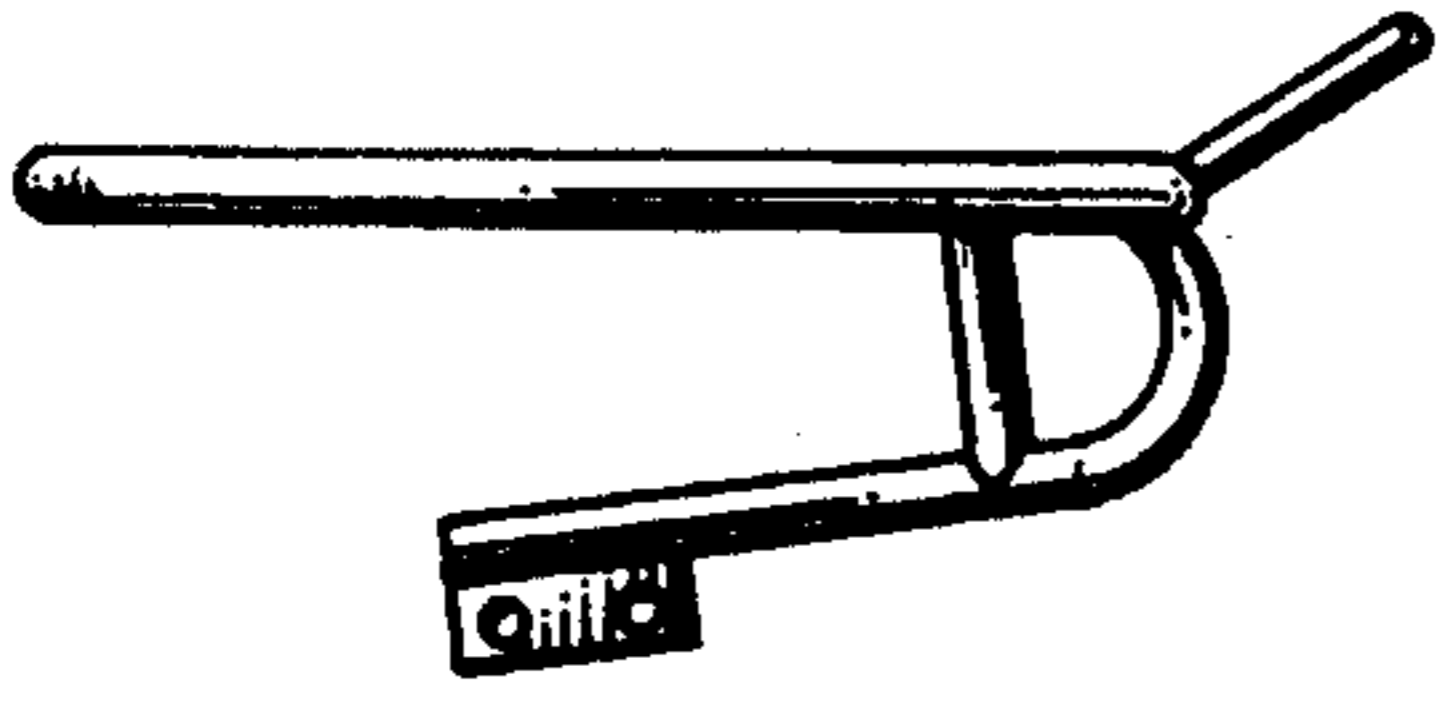

FIG. 4

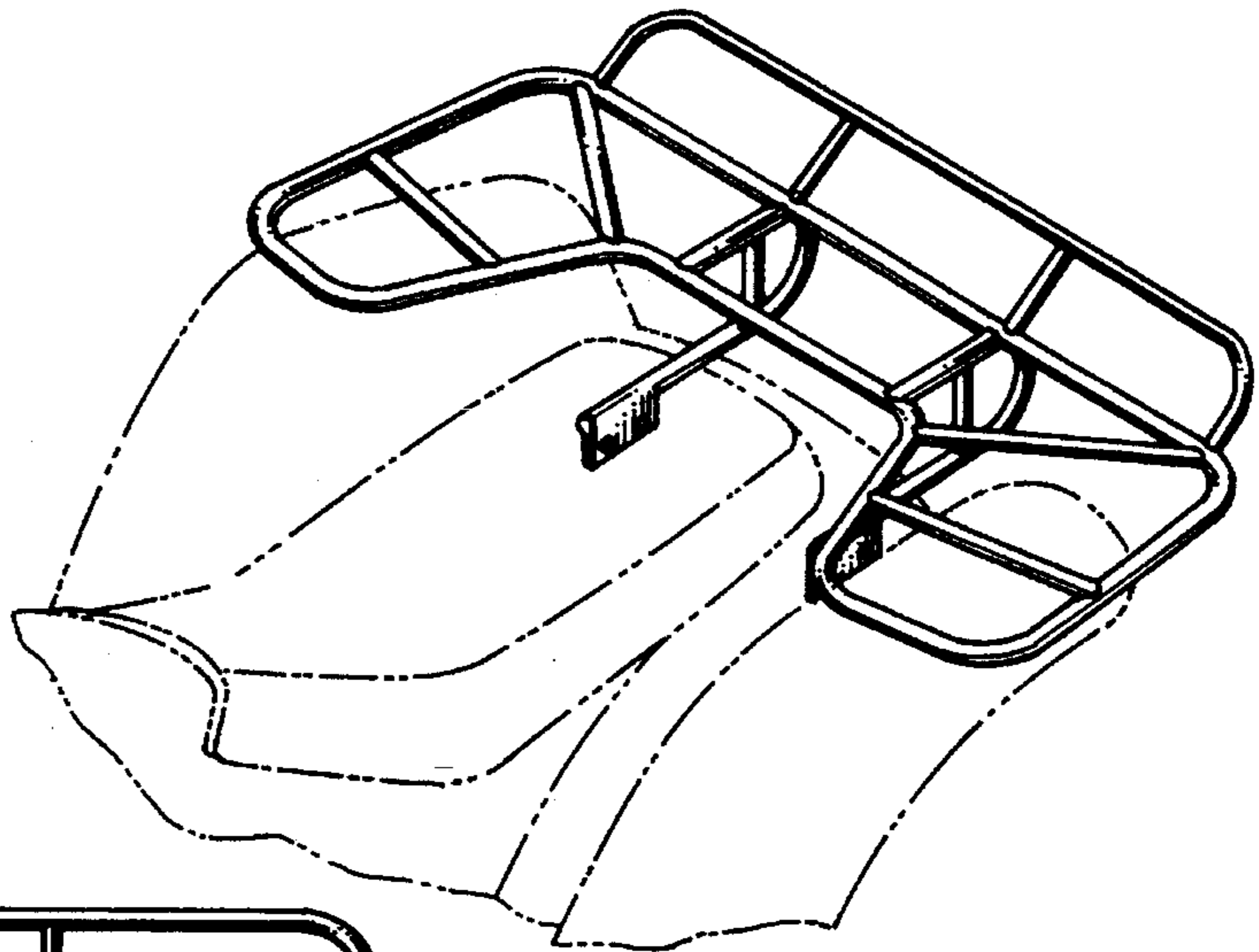

FIG. 6

FIG. 1

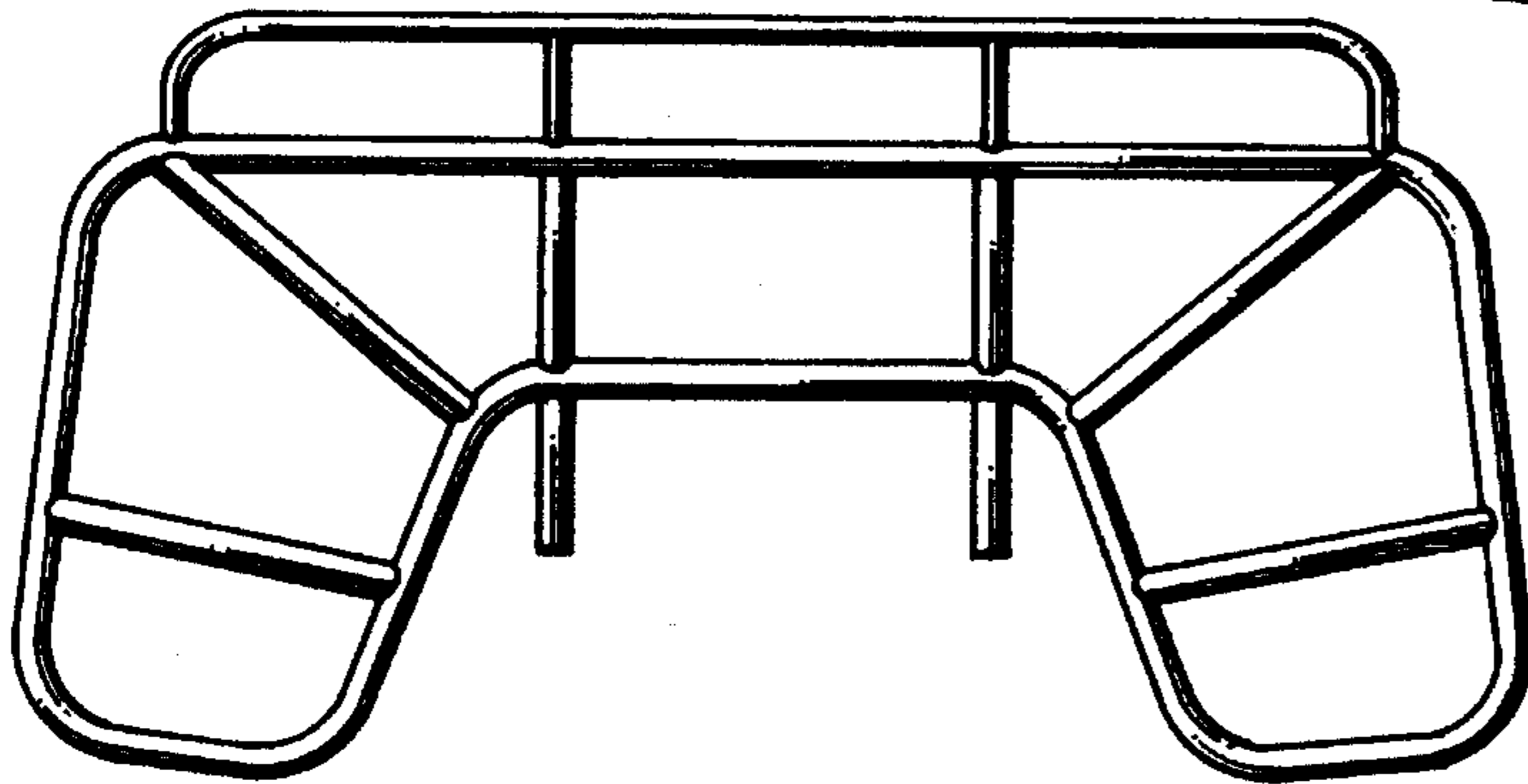

FIG. 7

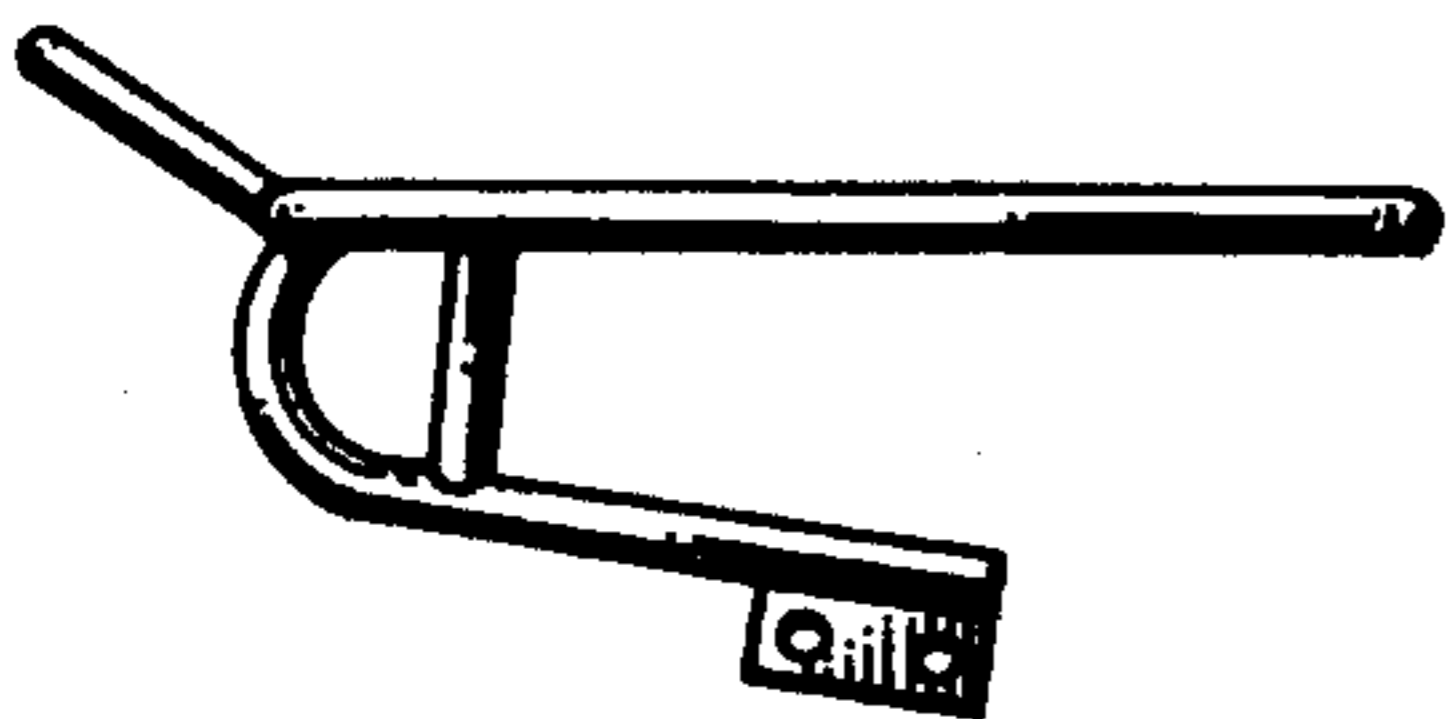

FIG. 5

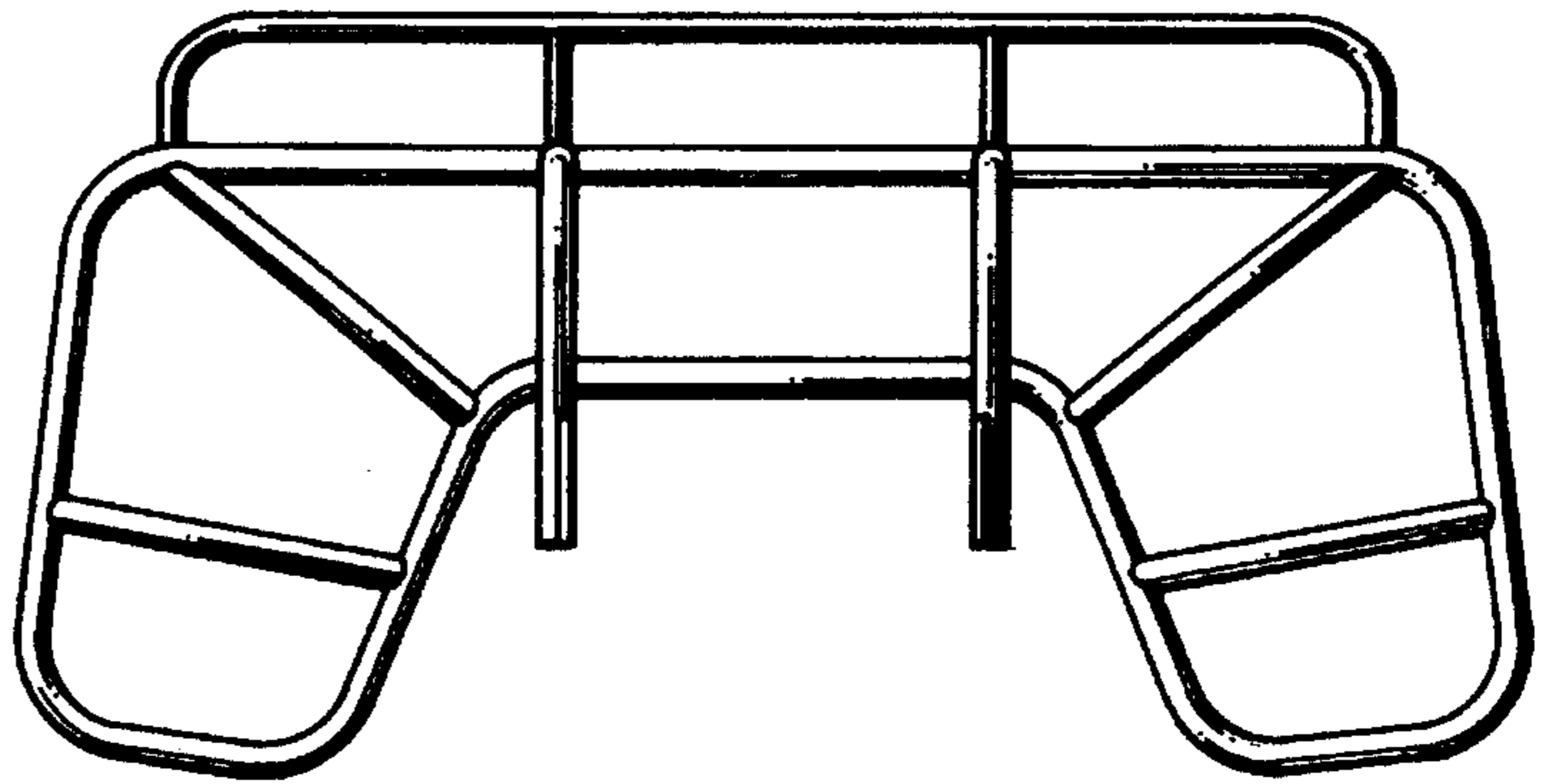

FIG. 3

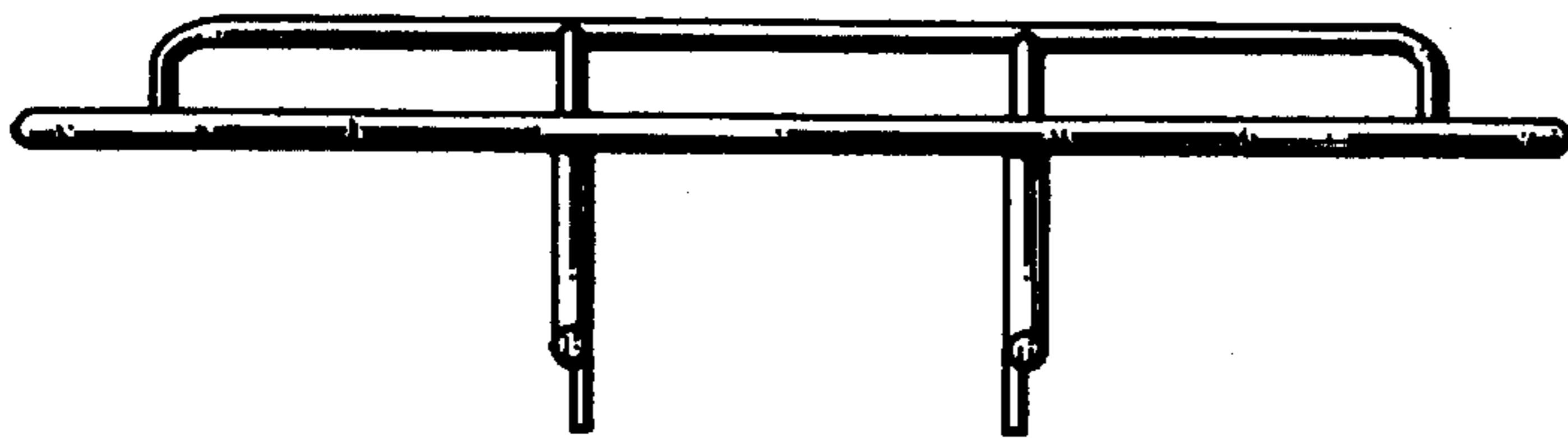

FIG. 2

