



US00D364023S

United States Patent [19] Johnson

[11] Patent Number: **Des. 364,023**

[45] Date of Patent: ****Nov. 7, 1995**

[54] CAMSHAFT REMOVAL KIT

3,995,903 12/1976 Ernst 294/81.3
4,936,616 6/1990 Williams .

[76] Inventor: **Samuel J. Johnson**, 1414 39th St., Fort Madison, Iowa 52627

Primary Examiner—A. Hugo Word
Assistant Examiner—Robin V. Taylor
Attorney, Agent, or Firm—Terry M. Gernstein

[**] Term: **14 Years**

[21] Appl. No.: **14,901**

[57] **CLAIM**

[22] Filed: **Nov. 4, 1993**

The ornamental design for a camshaft removal kit, as shown and described.

[52] U.S. Cl. **D34/28**

[58] Field of Search D34/28, 31, 33, D34/35; 294/81.1, 81.3, 67.5

DESCRIPTION

FIG. 1 is a front, top and side exploded view of a camshaft removal kit showing my new design;
FIG. 2 is a front elevational view thereof;
FIG. 3 is a rear elevational view thereof;
FIG. 4 is a side elevational view thereof;
FIG. 5 is a side elevational view thereof;
FIG. 6 is a top plan view thereof; and,
FIG. 7 is a bottom plan view thereof.

[56] **References Cited**

U.S. PATENT DOCUMENTS

| | | | |
|-----------|---------|-------------------------|----------|
| 1,535,022 | 4/1925 | Jenkins . | |
| 1,978,999 | 10/1934 | Jones | D34/33 |
| 2,412,488 | 12/1946 | Austin . | |
| 3,084,808 | 4/1963 | Peduzzi et al. | D34/33 |
| 3,751,097 | 8/1973 | Jones et al. | 294/81.3 |
| 3,955,844 | 5/1976 | de Castella et al. | 294/67.5 |

1 Claim, 5 Drawing Sheets

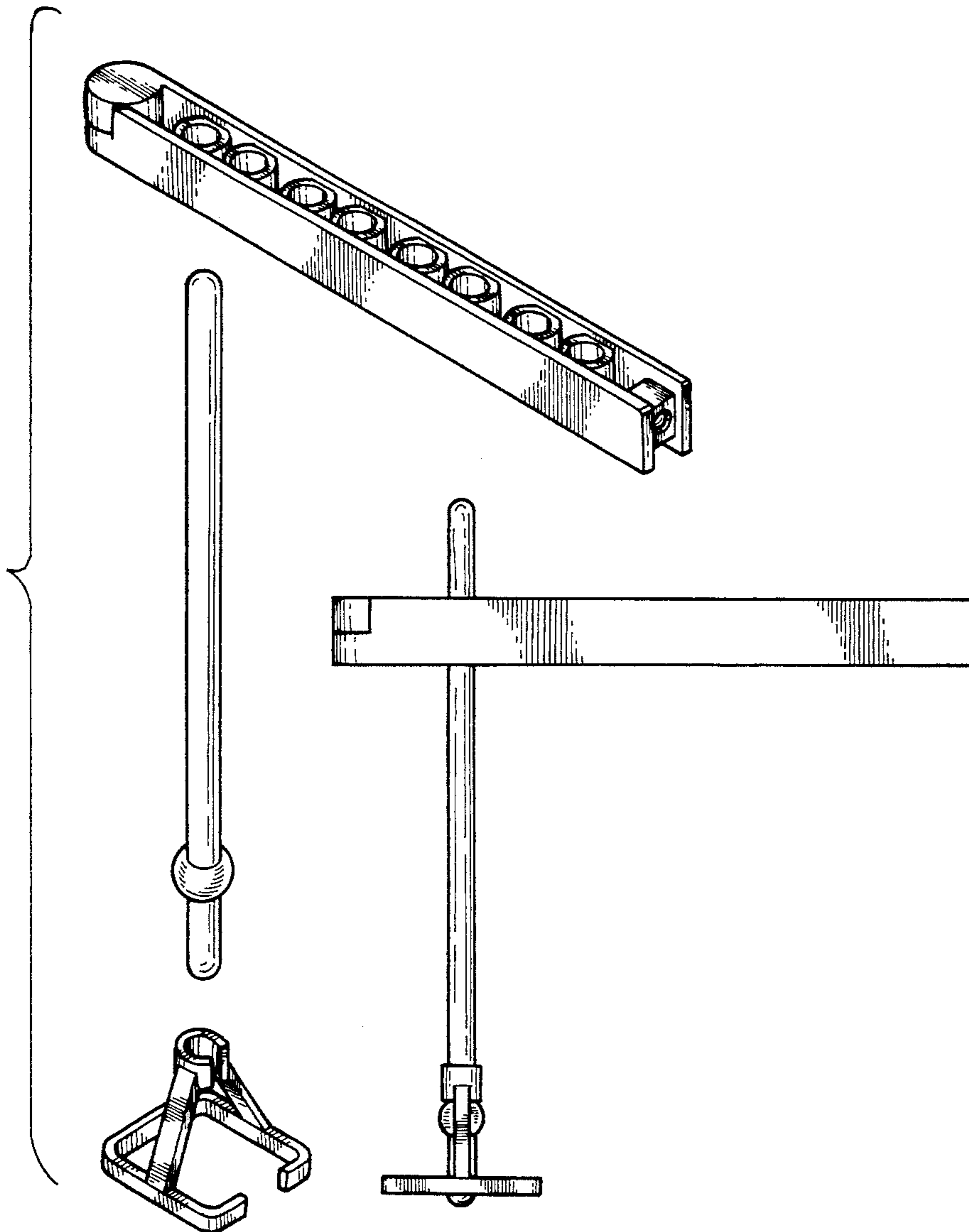

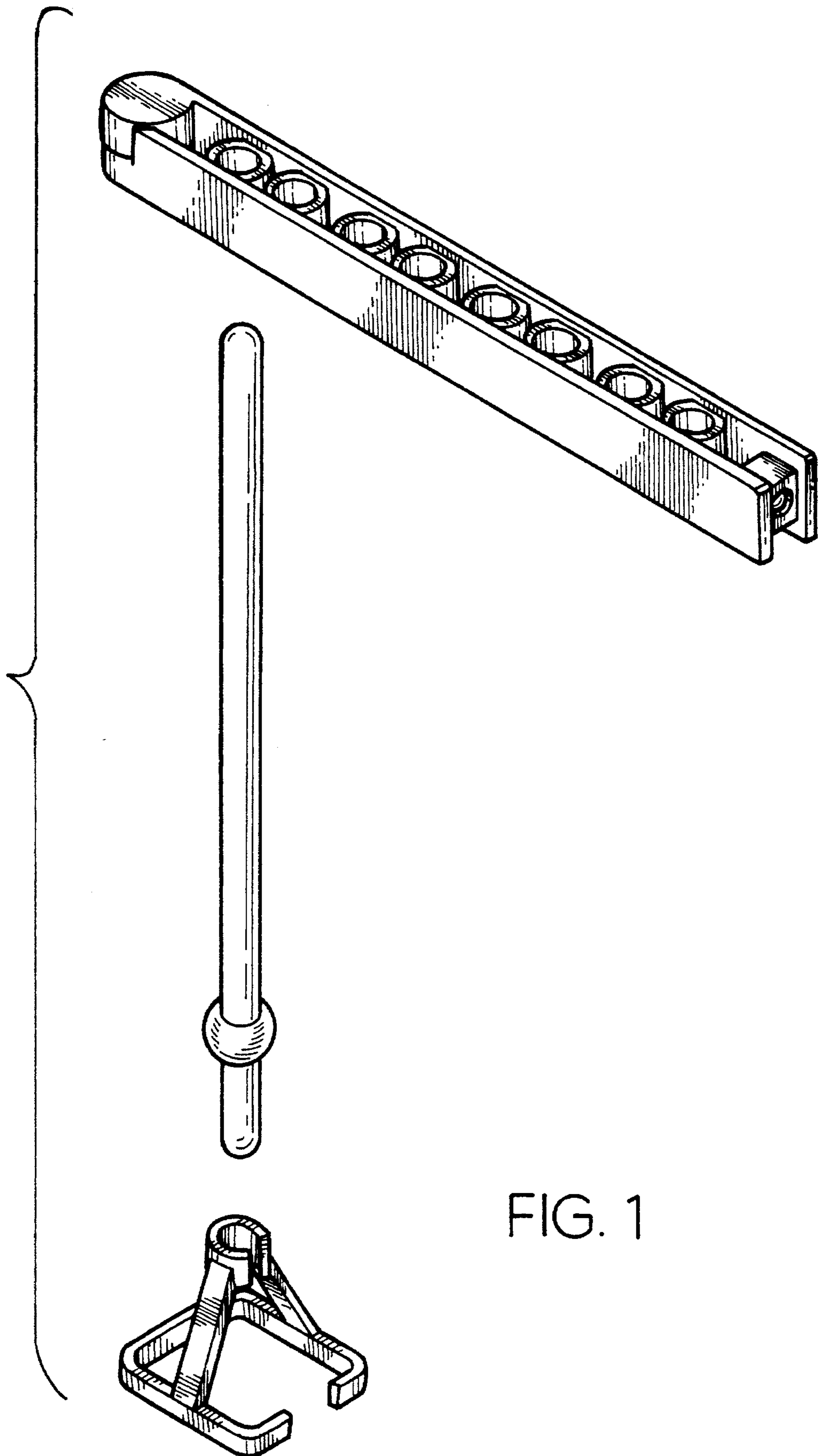

FIG. 1

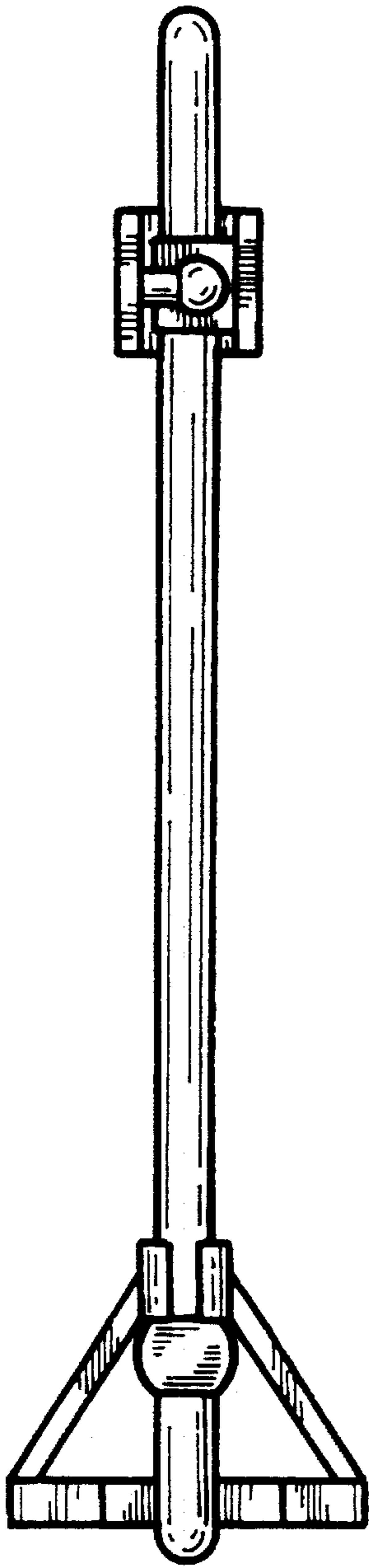

FIG. 2

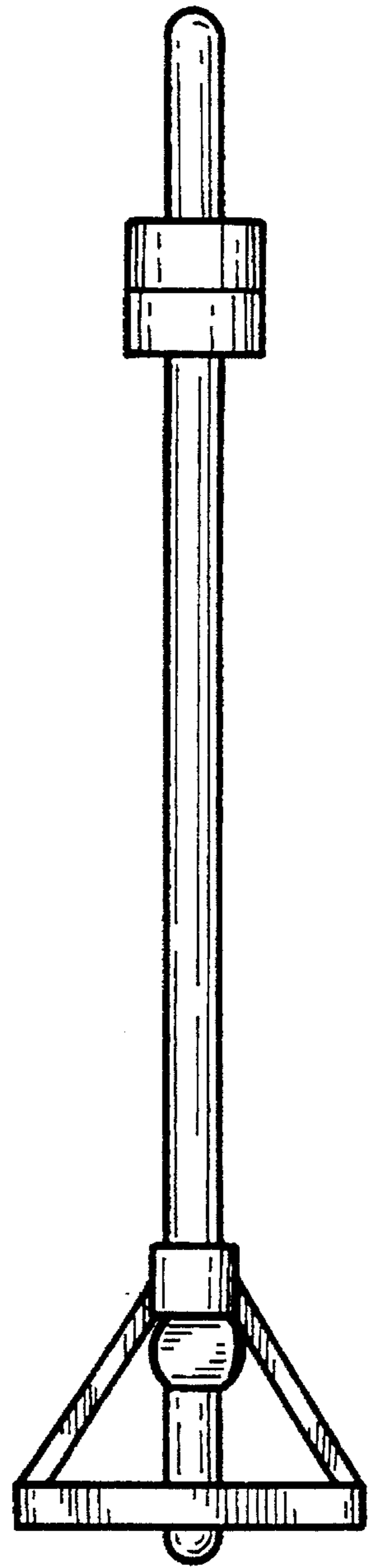

FIG. 3

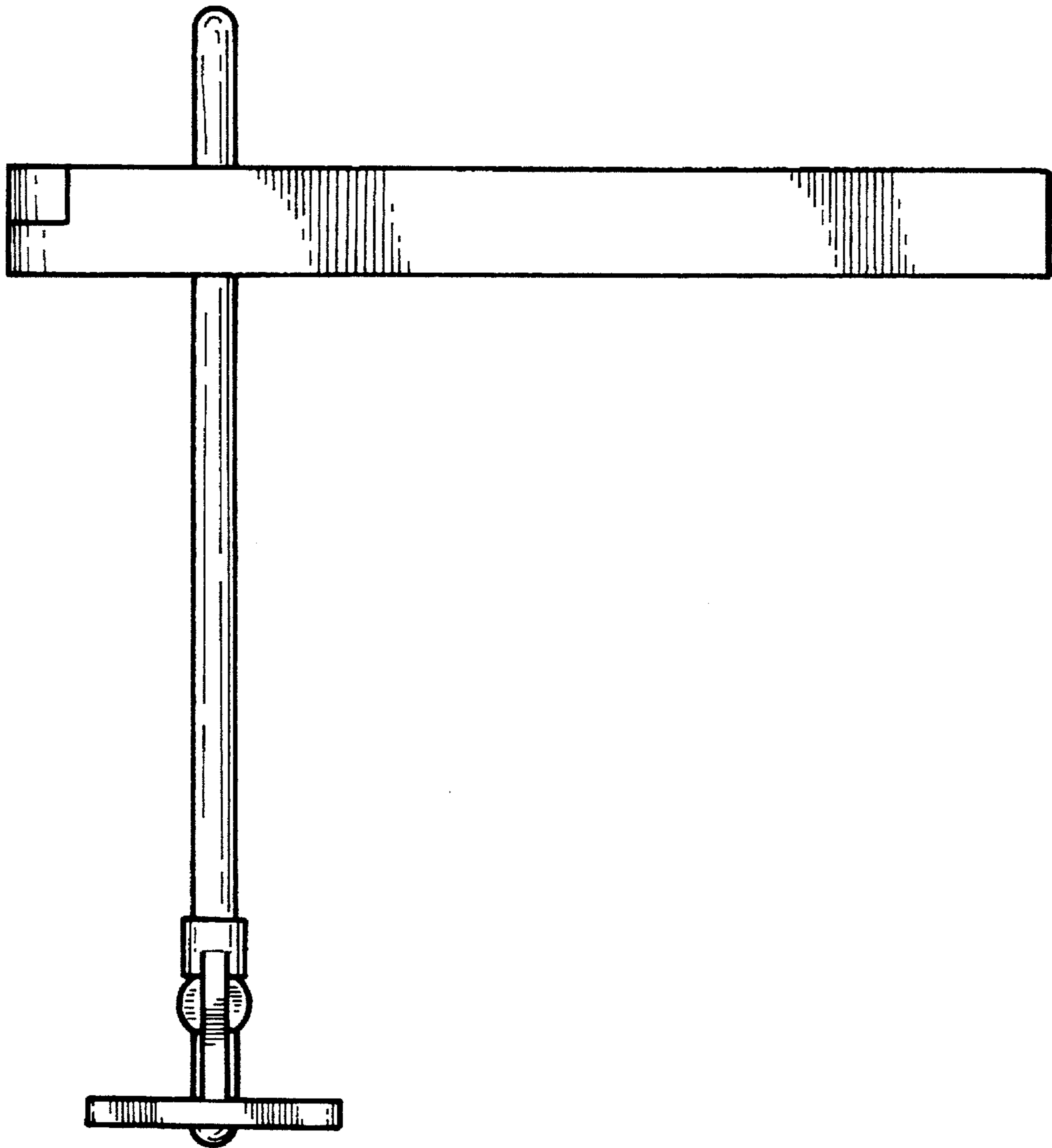

FIG. 4

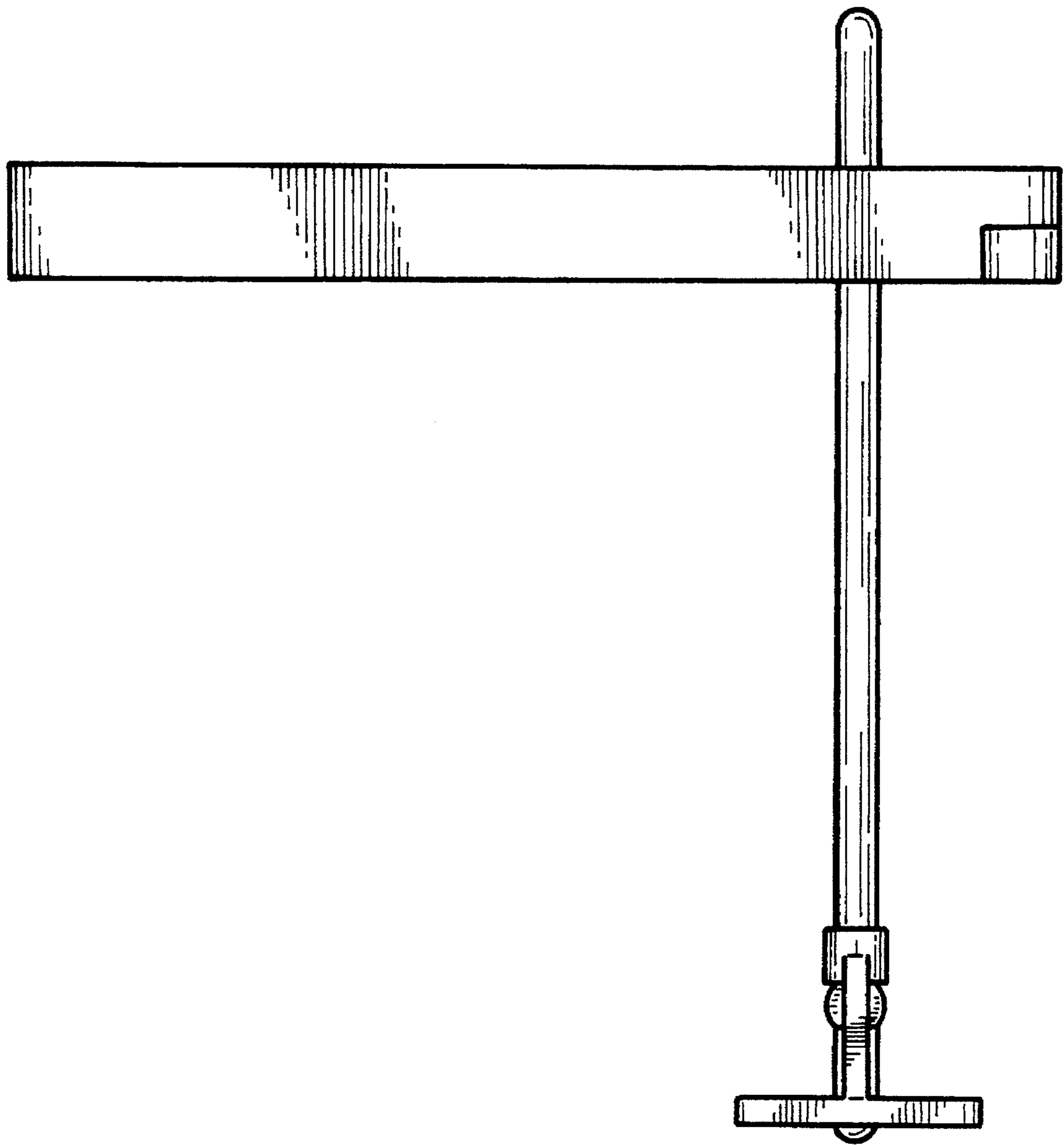

FIG. 5

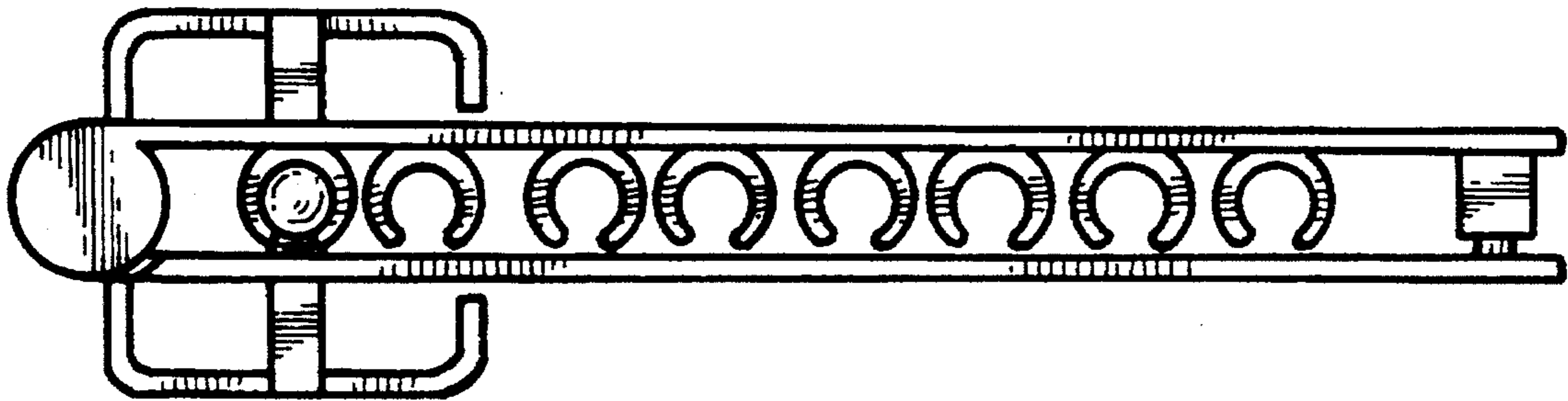

FIG. 6

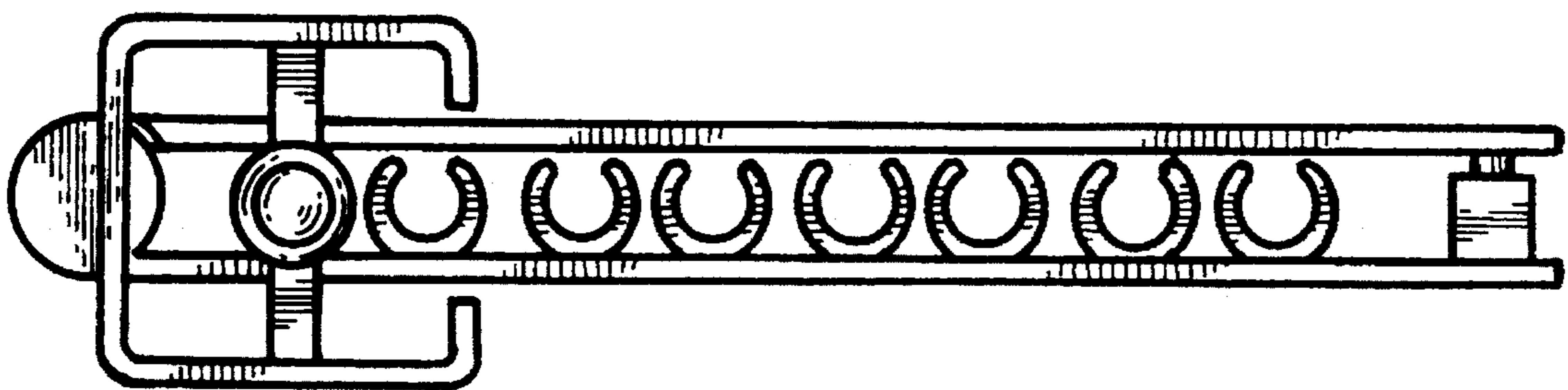

FIG. 7