



US00D363997S

# United States Patent [19]

Nomura

[11] Patent Number: **Des. 363,997**

[45] Date of Patent: **\*\*Nov. 7, 1995**

[54] **FRAME BAR FOR CONSTITUTING A FRAME STRUCTURE**

[75] Inventor: **Ryoichi Nomura**, Toyama, Japan

[73] Assignee: **Nic Autotec Co., Ltd.**, Toyama, Japan

[\*\*] Term: **14 Years**

[21] Appl. No.: **23,946**

[22] Filed: **Jun. 3, 1994**

[52] U.S. Cl. .... **D25/122; D25/61**

[58] Field of Search ..... **D25/122, 125, D25/124, 61; 52/648, 738, 731, 737, 732.1, 732.2, 782, 653.1, 653.2, 649.2, 649.3, 78; 160/371**

[56] **References Cited**

**U.S. PATENT DOCUMENTS**

D. 316,444	4/1991	Abbestan et al. ....	D25/122
D. 318,130	7/1991	Abbestan et al. ....	D25/122
D. 336,345	6/1993	Fasth et al. ....	D25/122
2,866,235	12/1958	Couse et al. ....	D25/61
3,513,606	5/1970	Jones ....	D25/122
4,250,679	2/1981	Burg ....	52/653.2
4,984,407	1/1991	Ziehmer ....	52/653.1
5,224,320	7/1993	Mai ....	52/648.1

*Primary Examiner*—Doris Clark

*Attorney, Agent, or Firm*—Frishauf, Holtz, Goodman & Woodward

[57] **CLAIM**

The ornamental design for a frame bar for constituting a frame structure, as shown and described.

**DESCRIPTION**

FIG. 1 is a front elevation of a frame bar for constituting a

frame structure, showing a first embodiment of my new design, the rear elevational view being a mirror image of the side shown;

FIG. 2 is a top plan view thereof, the bottom plan view being a mirror image of the side shown;

FIG. 3 is a side elevation thereof; the opposite side being a mirror image of the side shown;

FIG. 4 is a perspective view thereof;

FIG. 5 is a front elevation of a frame bar for constituting a frame structure, showing a second embodiment of my new design, the rear elevational view being a mirror image of the side shown;

FIG. 6 is a top plan view thereof, the bottom plan view being a mirror image of the side shown;

FIG. 7 is a side elevation thereof; the opposite side being a mirror image of the side shown;

FIG. 8 is a perspective view thereof;

FIG. 9 is a front elevation of a frame bar for constituting a frame structure, showing a third embodiment of my new design, the rear elevational view being a mirror image of the side shown;

FIG. 10 is a top plan view thereof, the bottom plan view being a mirror image of the side shown;

FIG. 11 is a side elevation thereof; the opposite side being a mirror image of the side shown; and,

FIG. 12 is a perspective view thereof.

The frame bar for constituting the frame structure has been broken away in FIGS. 2, 3, 4, 6, 7, 8, 10, 11 and 12 to indicate indeterminate length.

**1 Claim, 6 Drawing Sheets**

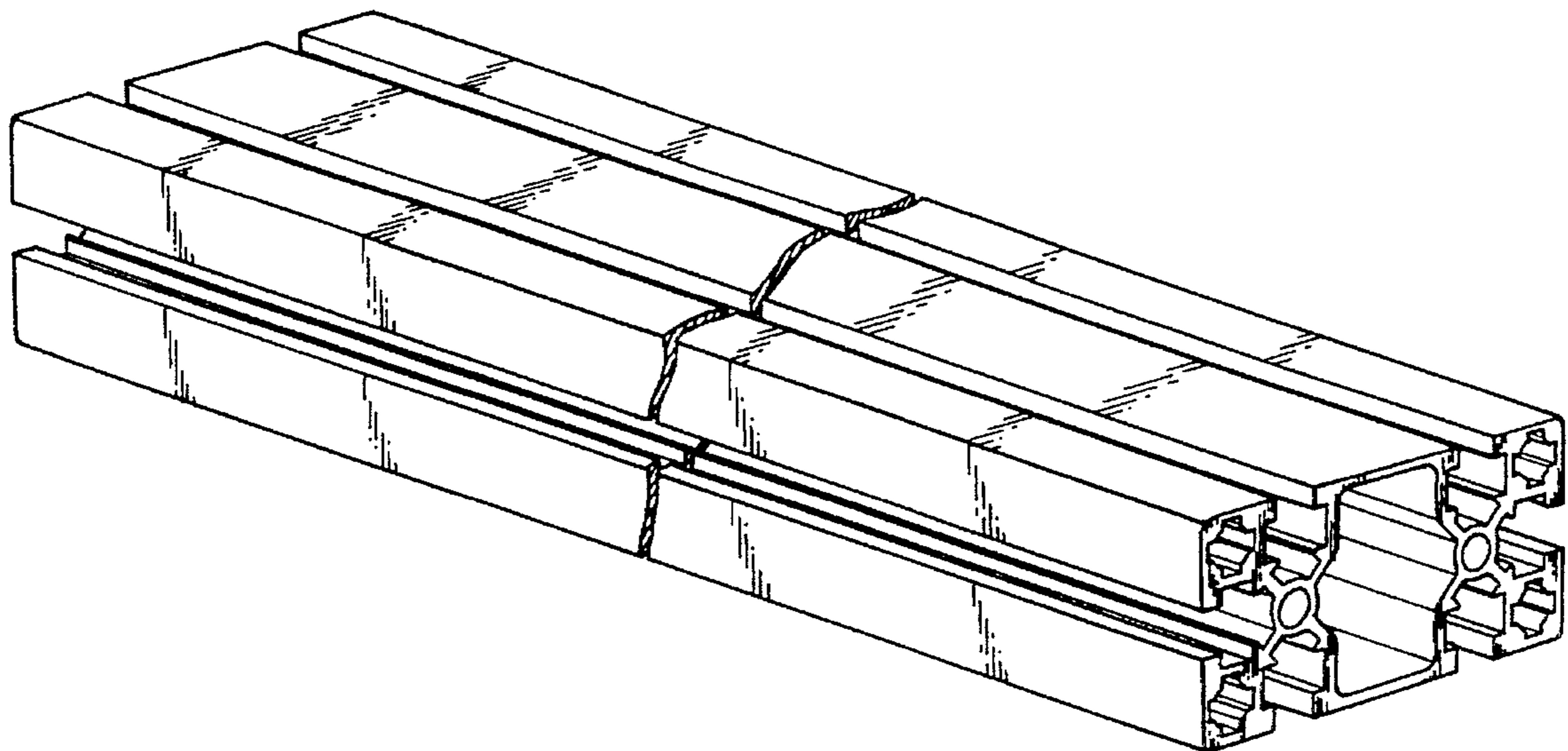

F I G . 2

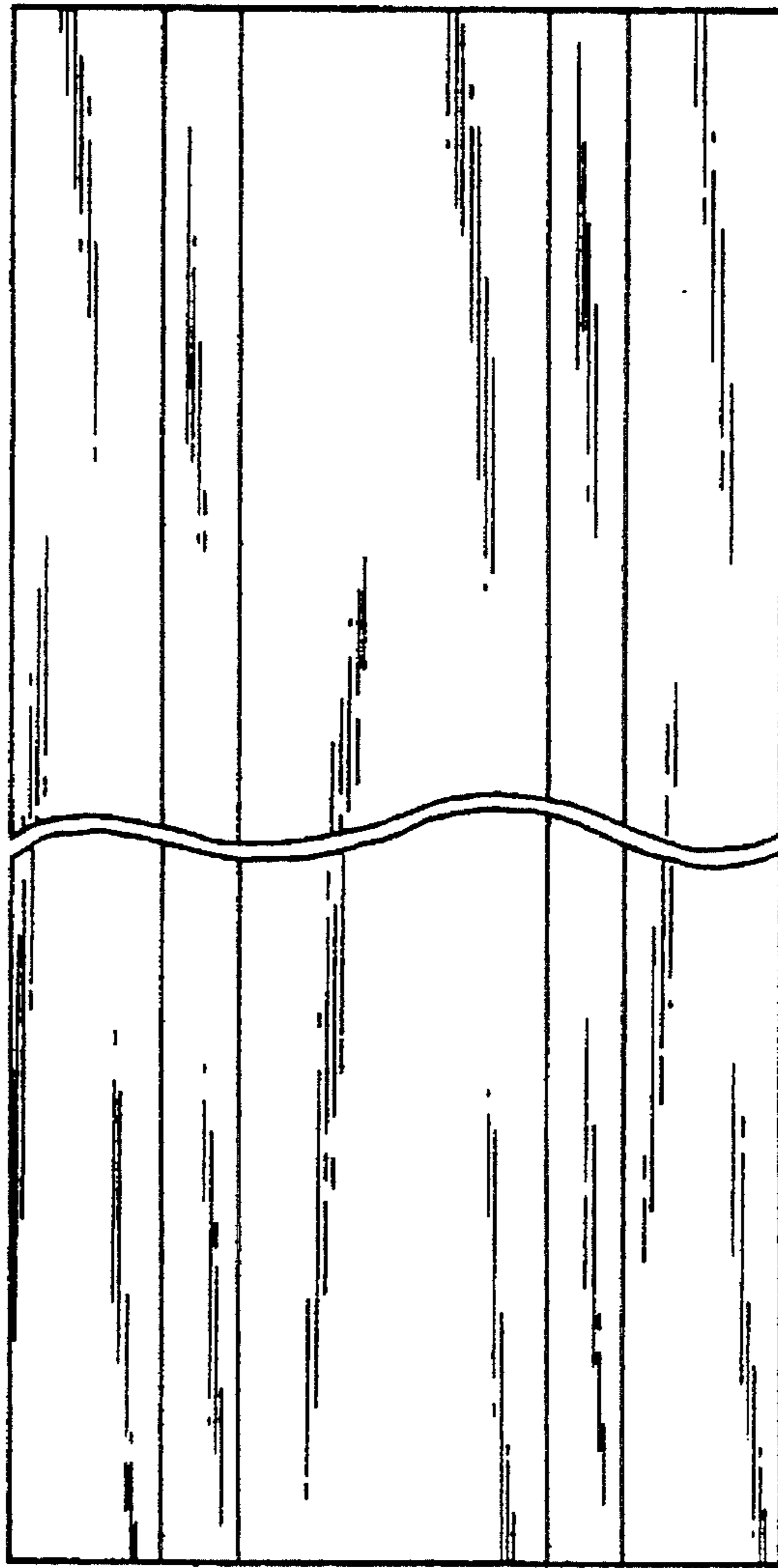

F I G . 1

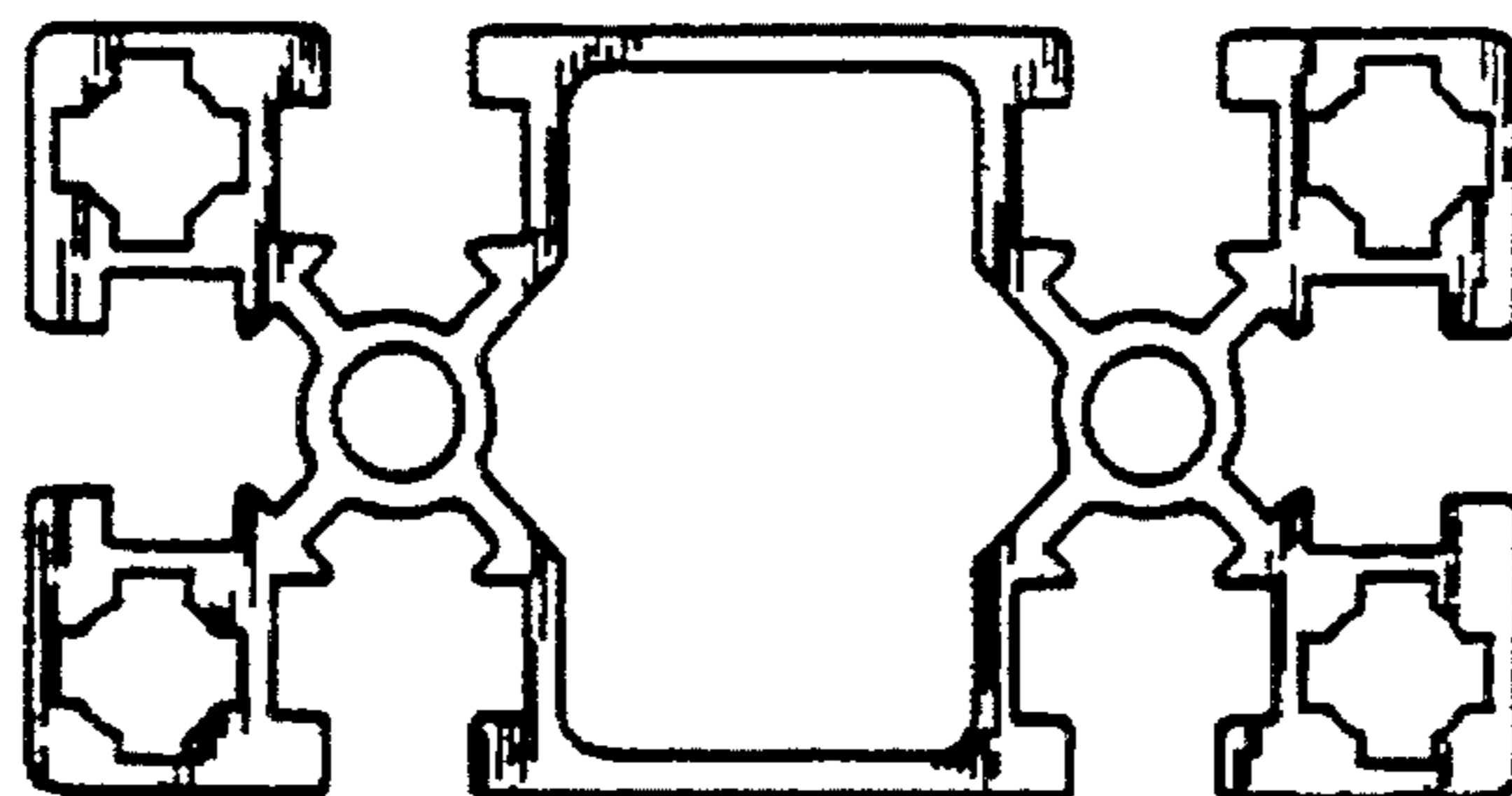

F I G. 3

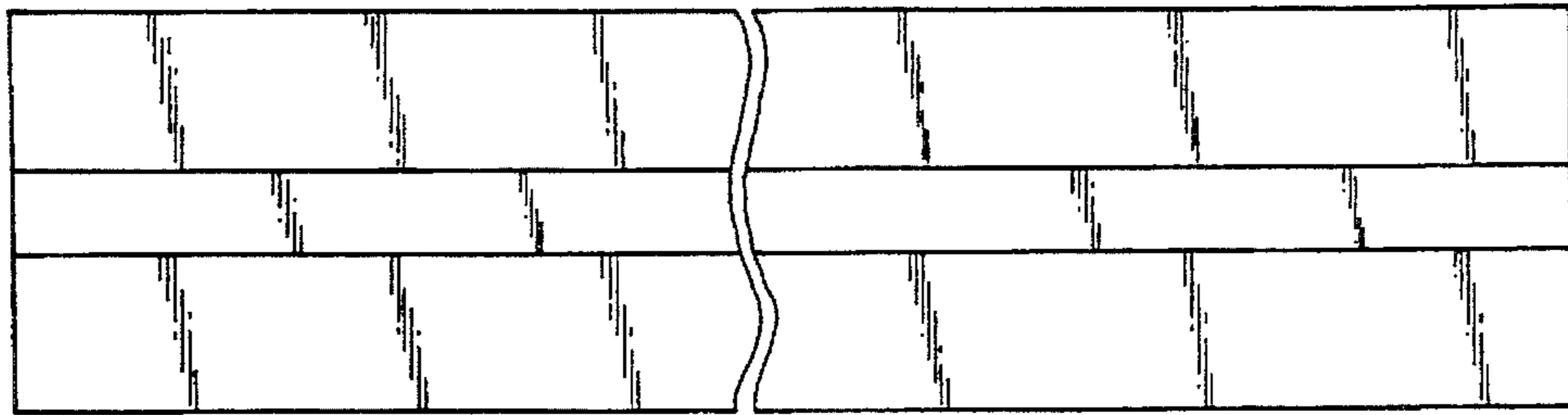

F I G. 4

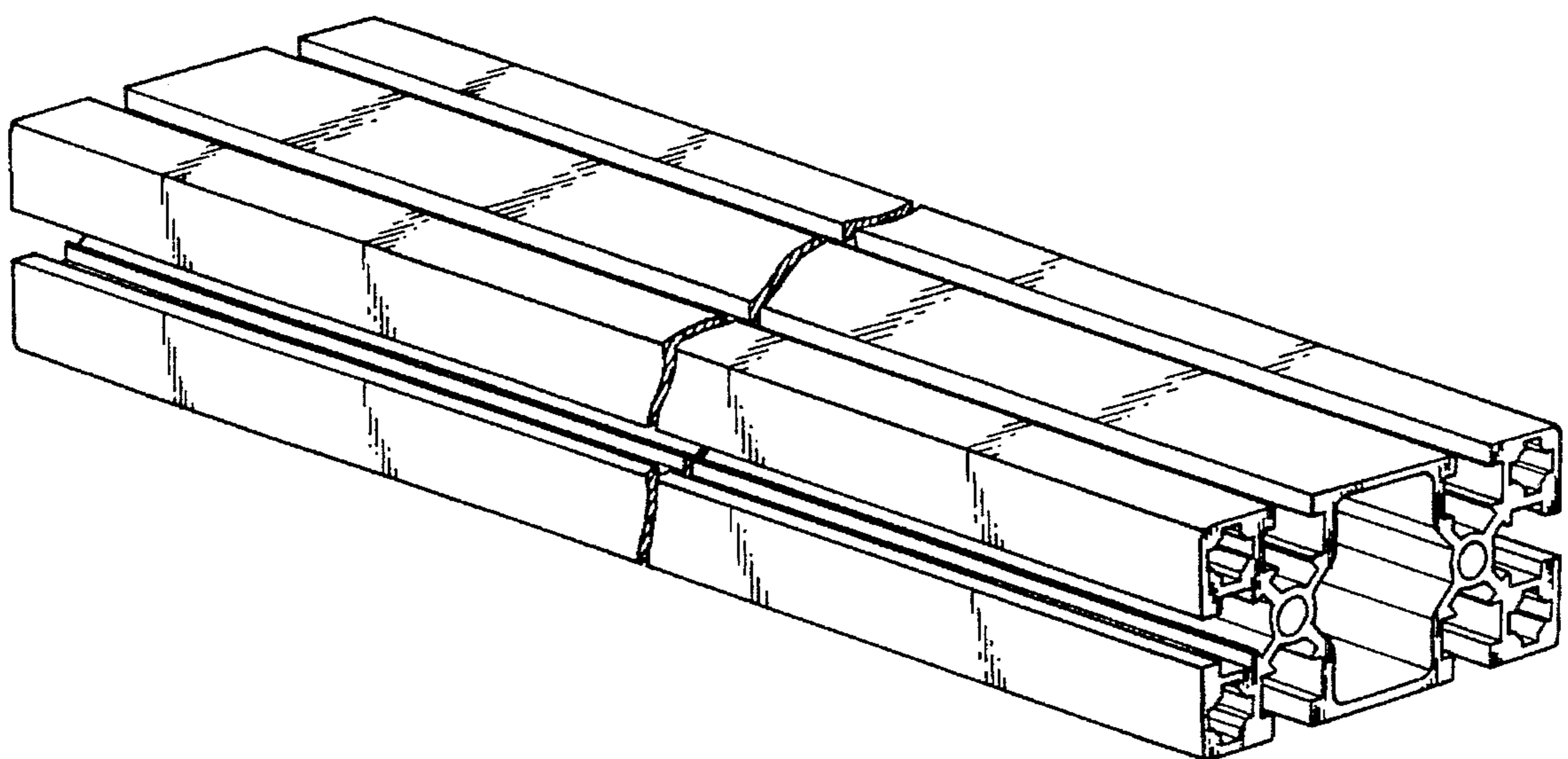

FIG. 6

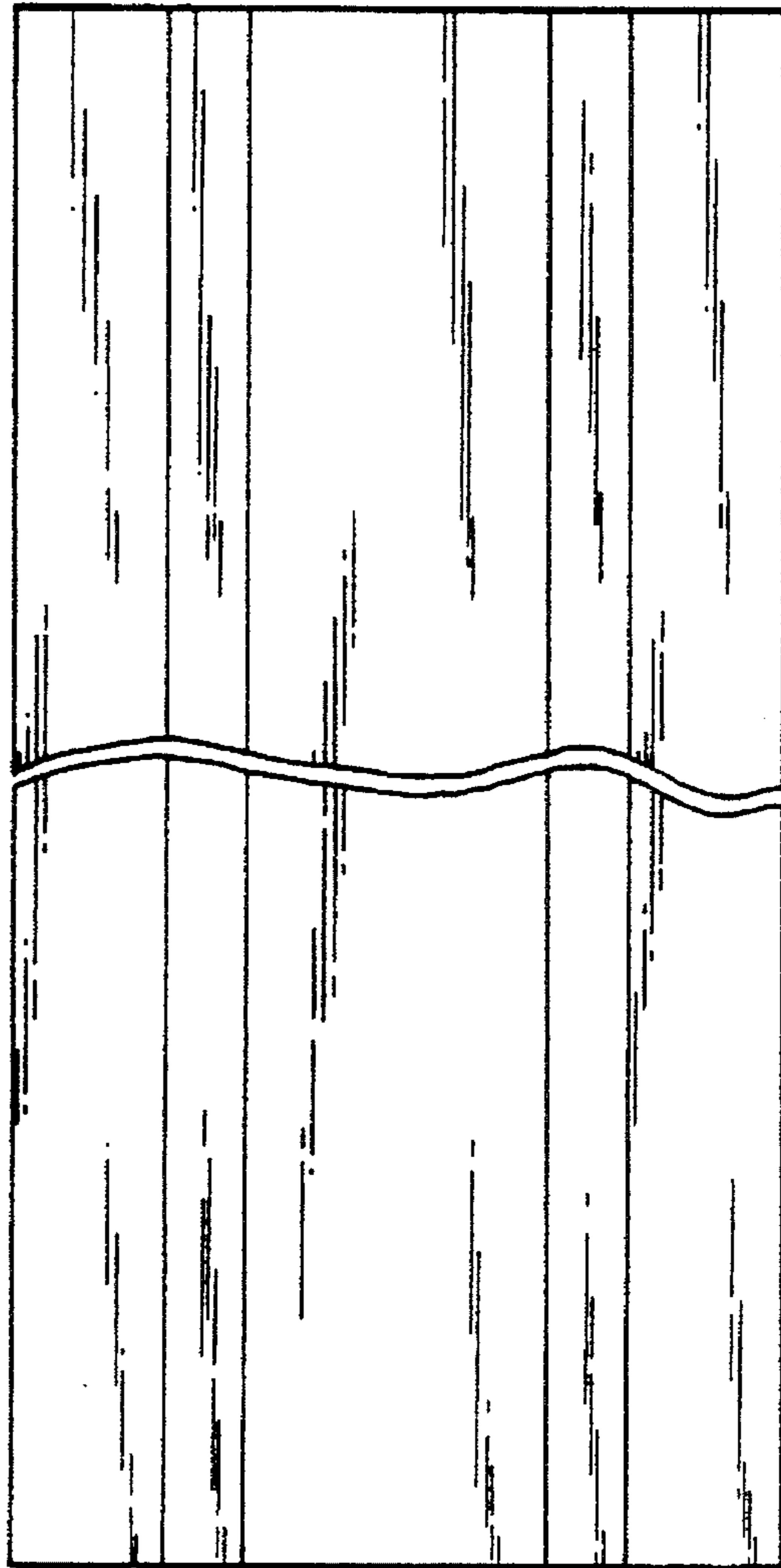
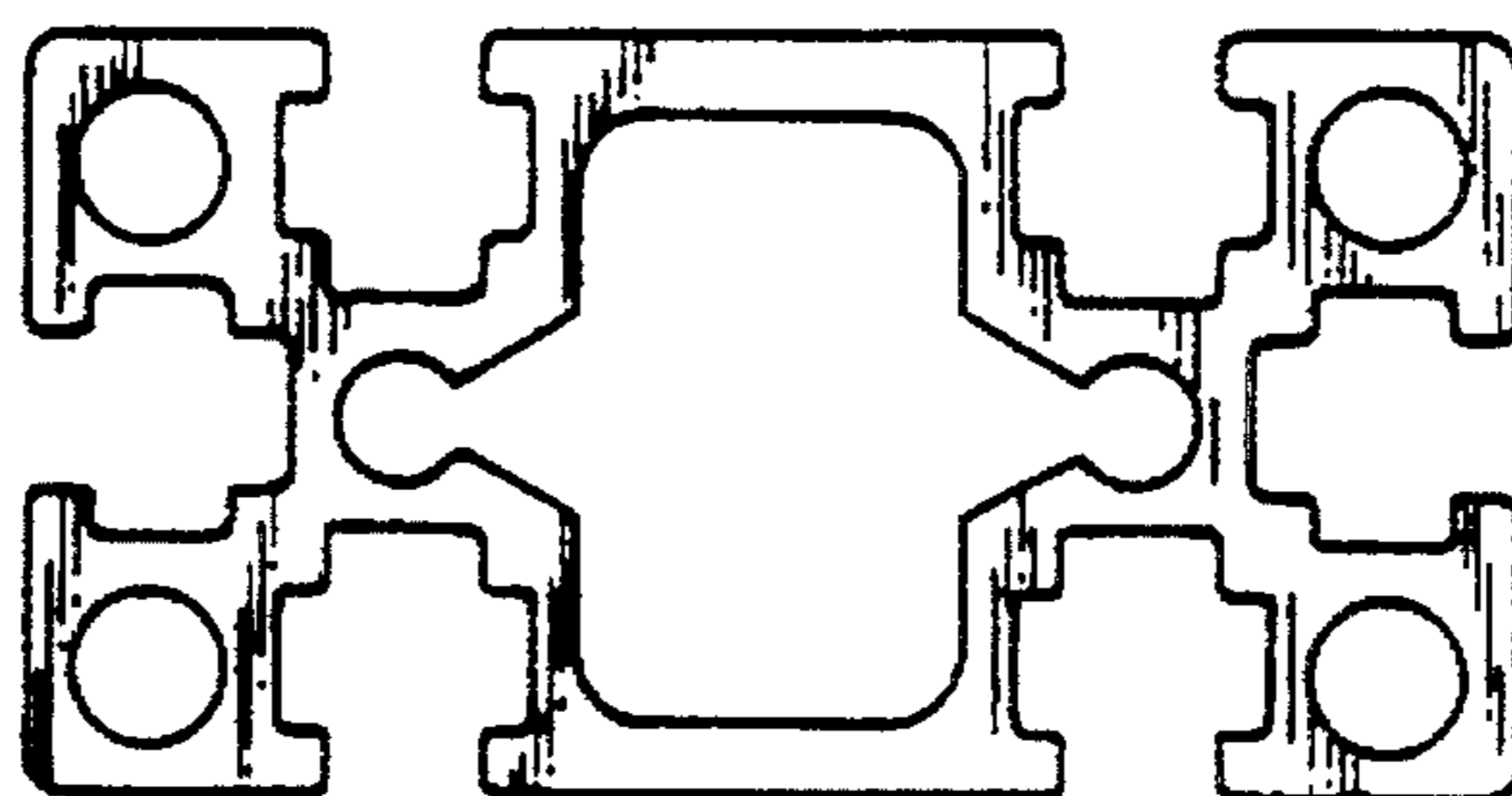
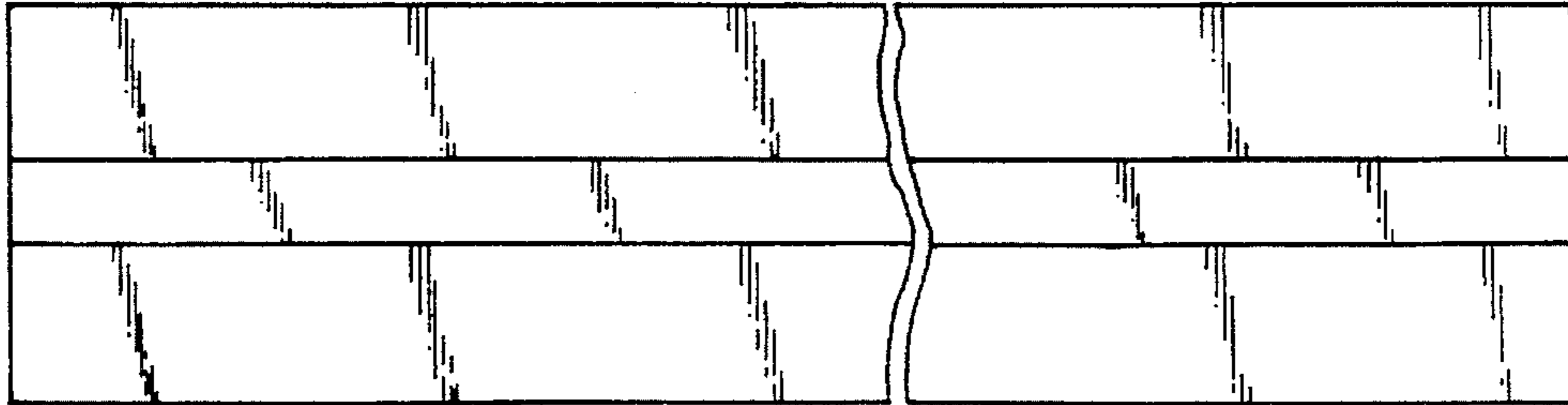

FIG. 5



F I G . 7



F I G . 8

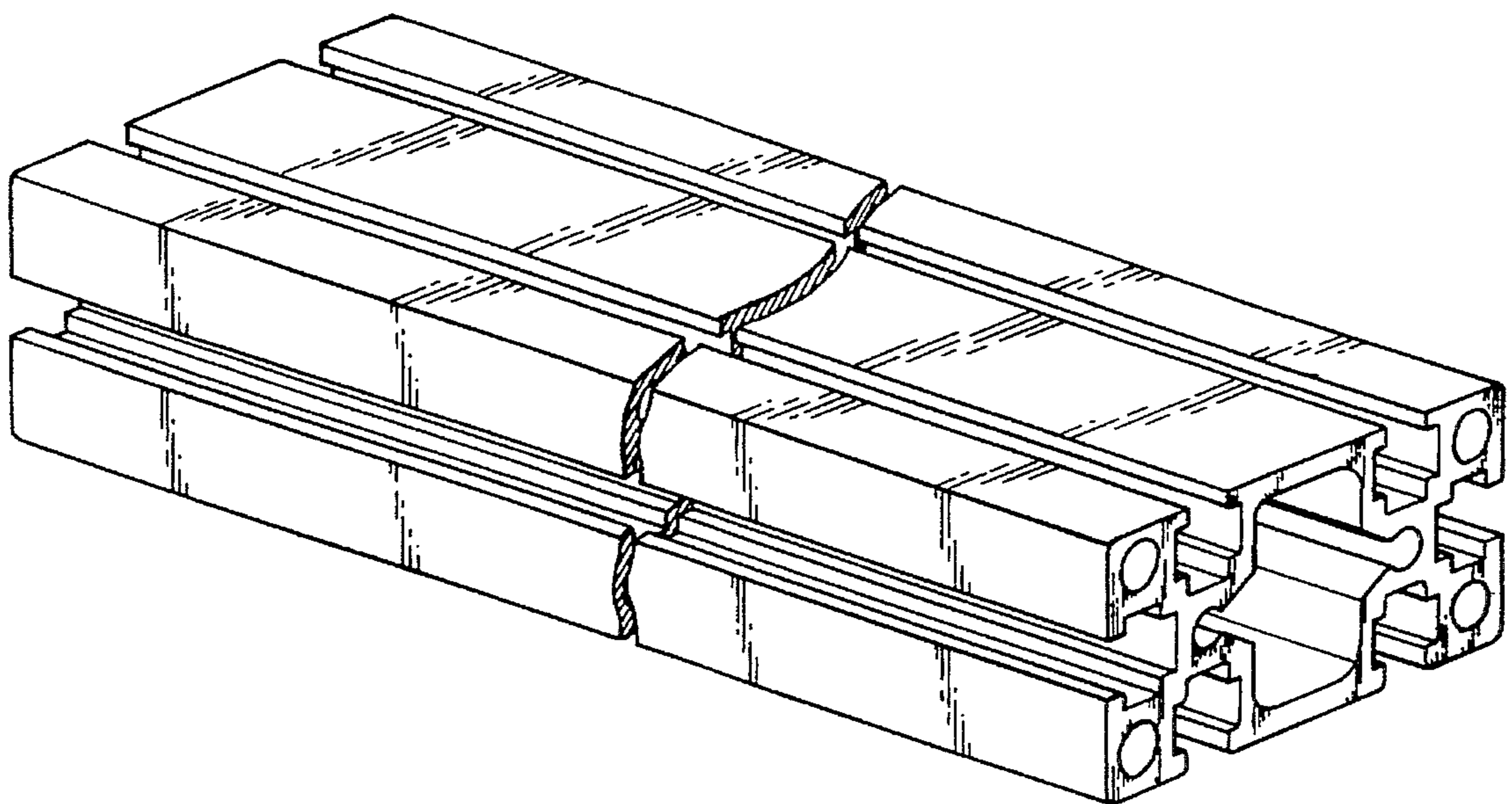

F I G. 10

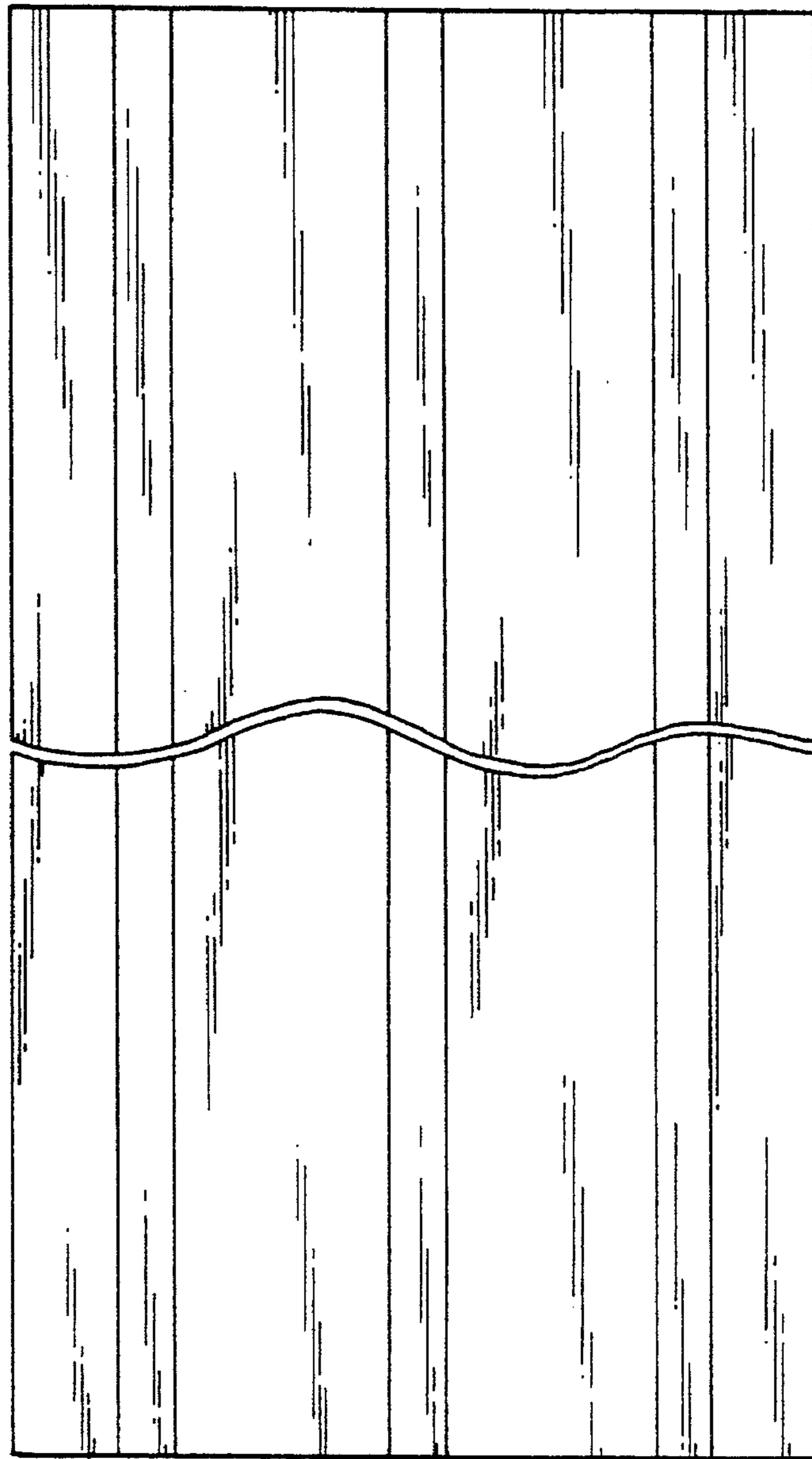

F I G. 9

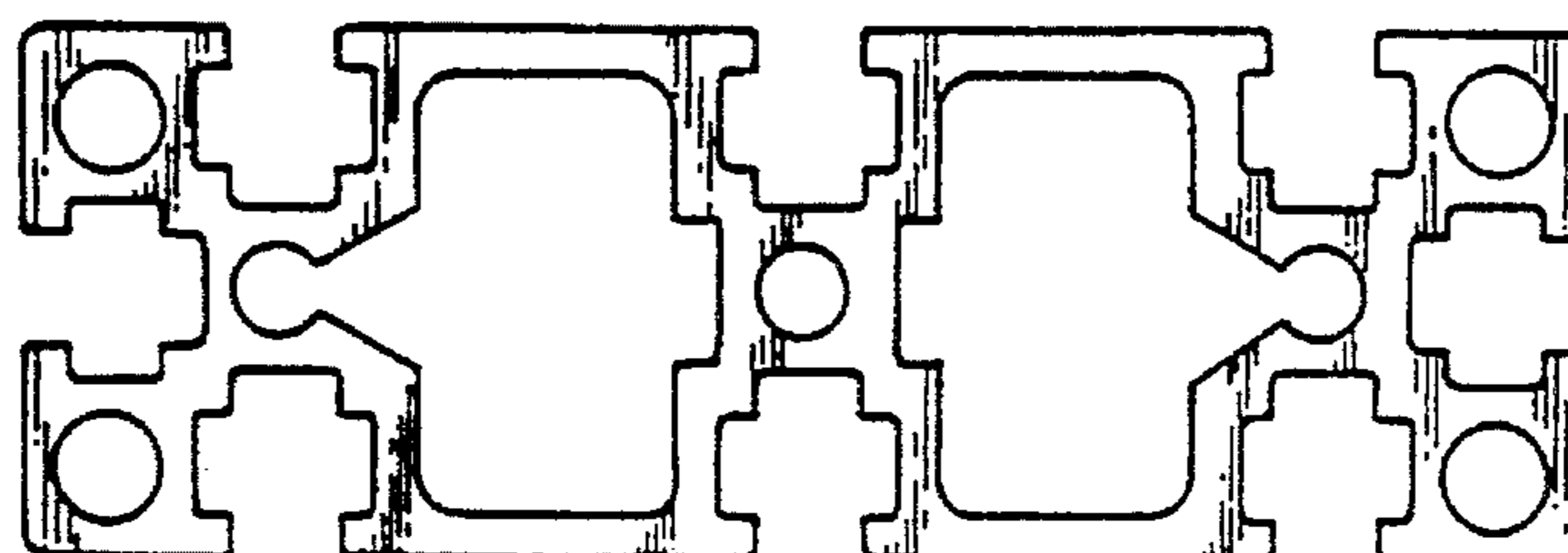

F I G. 11

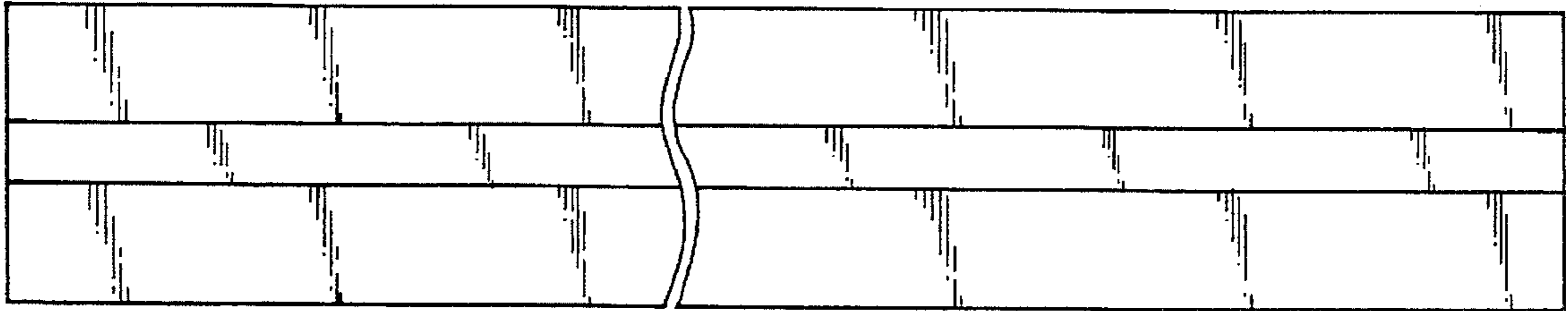

F I G. 12

