



US00D363980S

# United States Patent [19]

[11] Patent Number: **Des. 363,980**

**Roach**

[45] Date of Patent: **\*\*Nov. 7, 1995**

[54] **AIR CONDITIONER HOUSING UNIT FOR THE PASSENGER COMPARTMENT OF A VAN**

*Primary Examiner*—Lisa P. Lichtenstein  
*Attorney, Agent, or Firm*—James E. Bradley; Grady K. Bergen

[75] Inventor: **Robert E. Roach**, Arlington, Tex.

### [57] CLAIM

[73] Assignee: **Specific Cruise Systems, Inc.**, Fort Worth, Tex.

The ornamental design for an air conditioner housing unit for the passenger compartment of a van, as shown and described.

[\*\*] Term: **14 Years**

### DESCRIPTION

[21] Appl. No.: **7,951**

FIG. 1 is a left-front perspective view of the air conditioner housing unit with the rear top element in open condition, the manifold of the housing unit being shown in broken lines for illustrative purposes only and forming no part of the claimed design;

[22] Filed: **May 5, 1993**

[52] U.S. Cl. .... **D23/325**

[58] Field of Search ..... D23/325, 351;  
454/143

FIG. 2 is a right side elevational view thereof, the opposite side being a mirror image of that shown;

FIG. 3 is a top plan view thereof;

FIG. 4 is a front elevational view thereof;

FIG. 5 is a rear elevational view thereof; and,

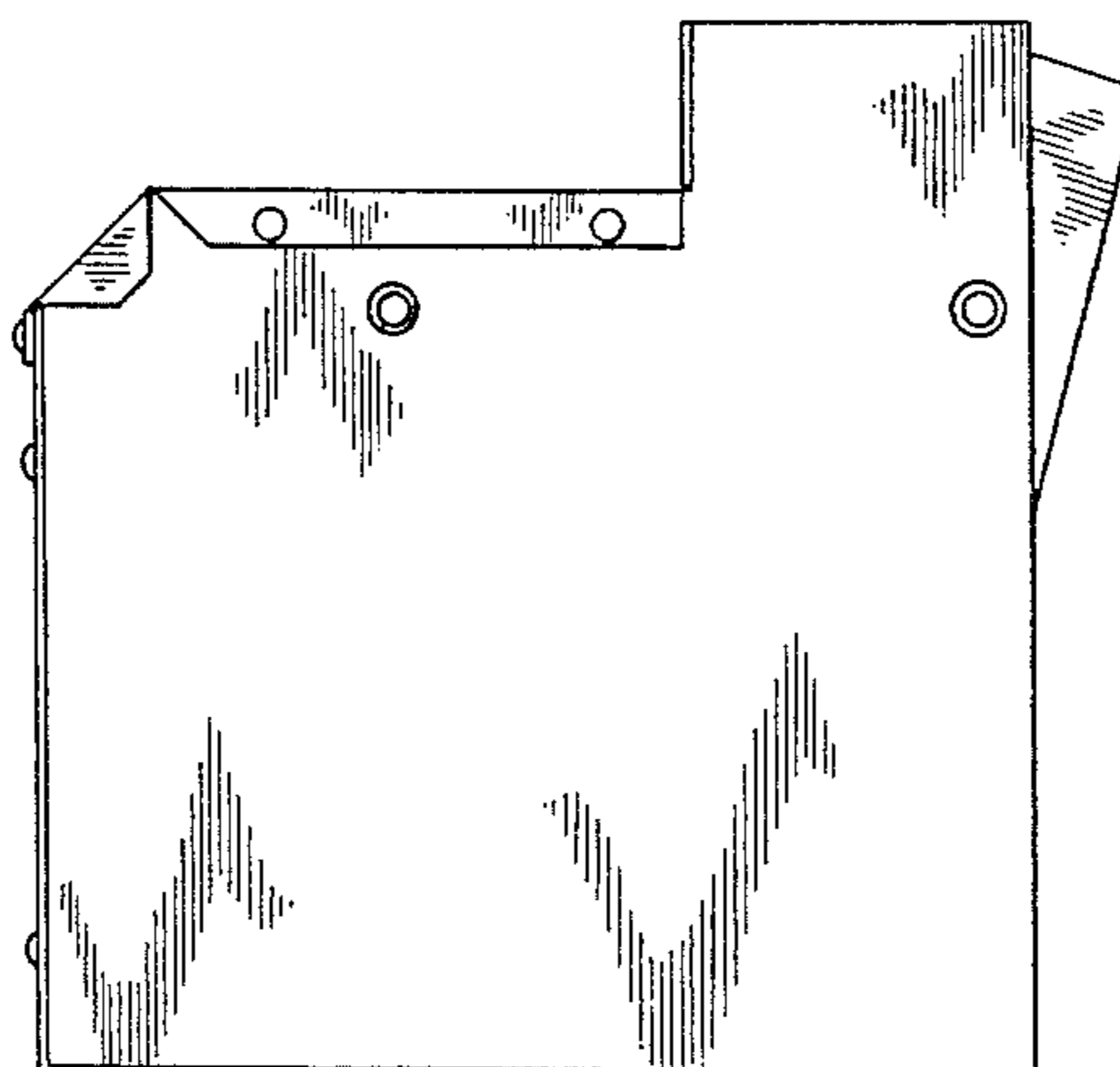
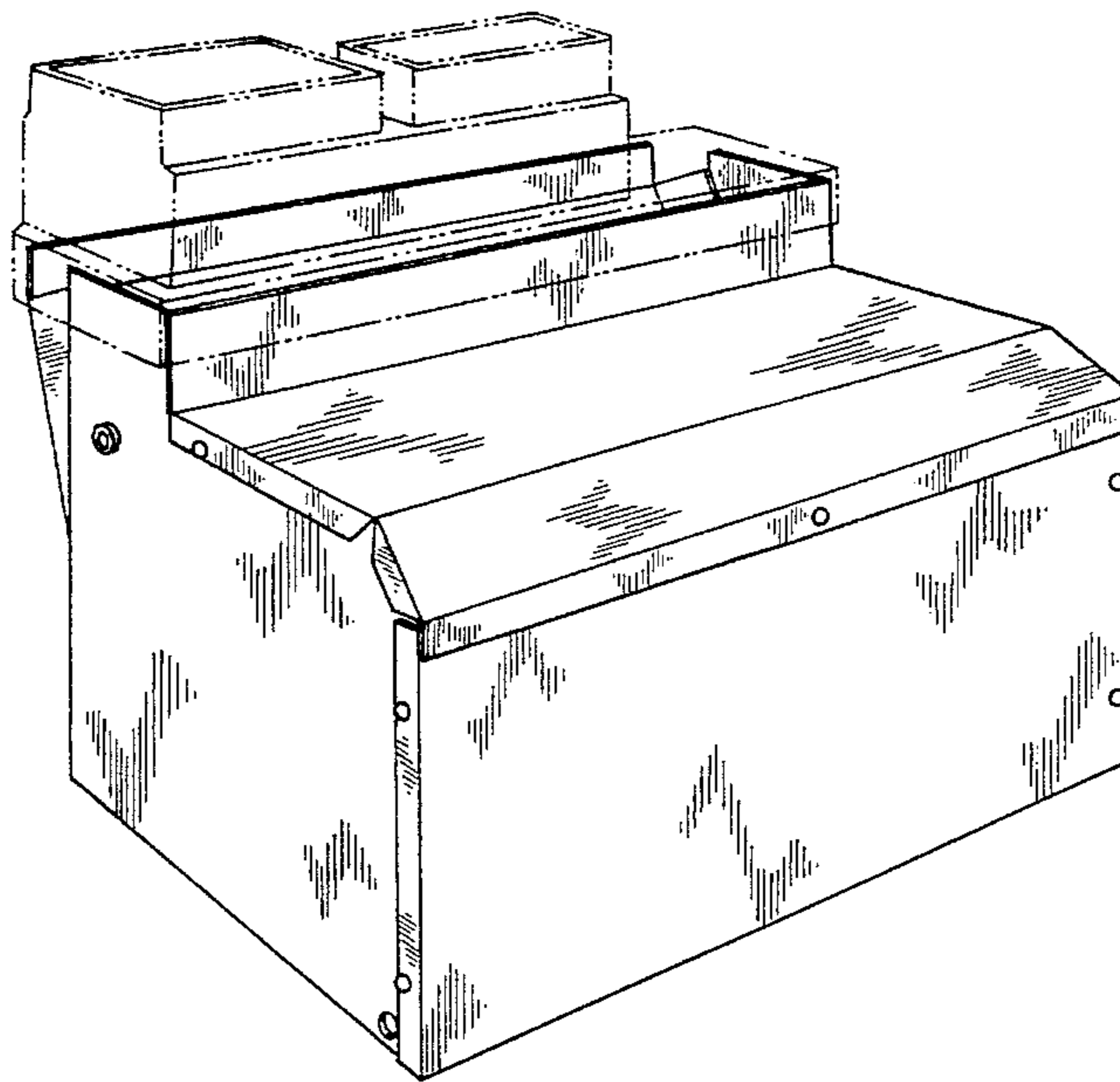
FIG. 6 is a bottom plan view thereof.

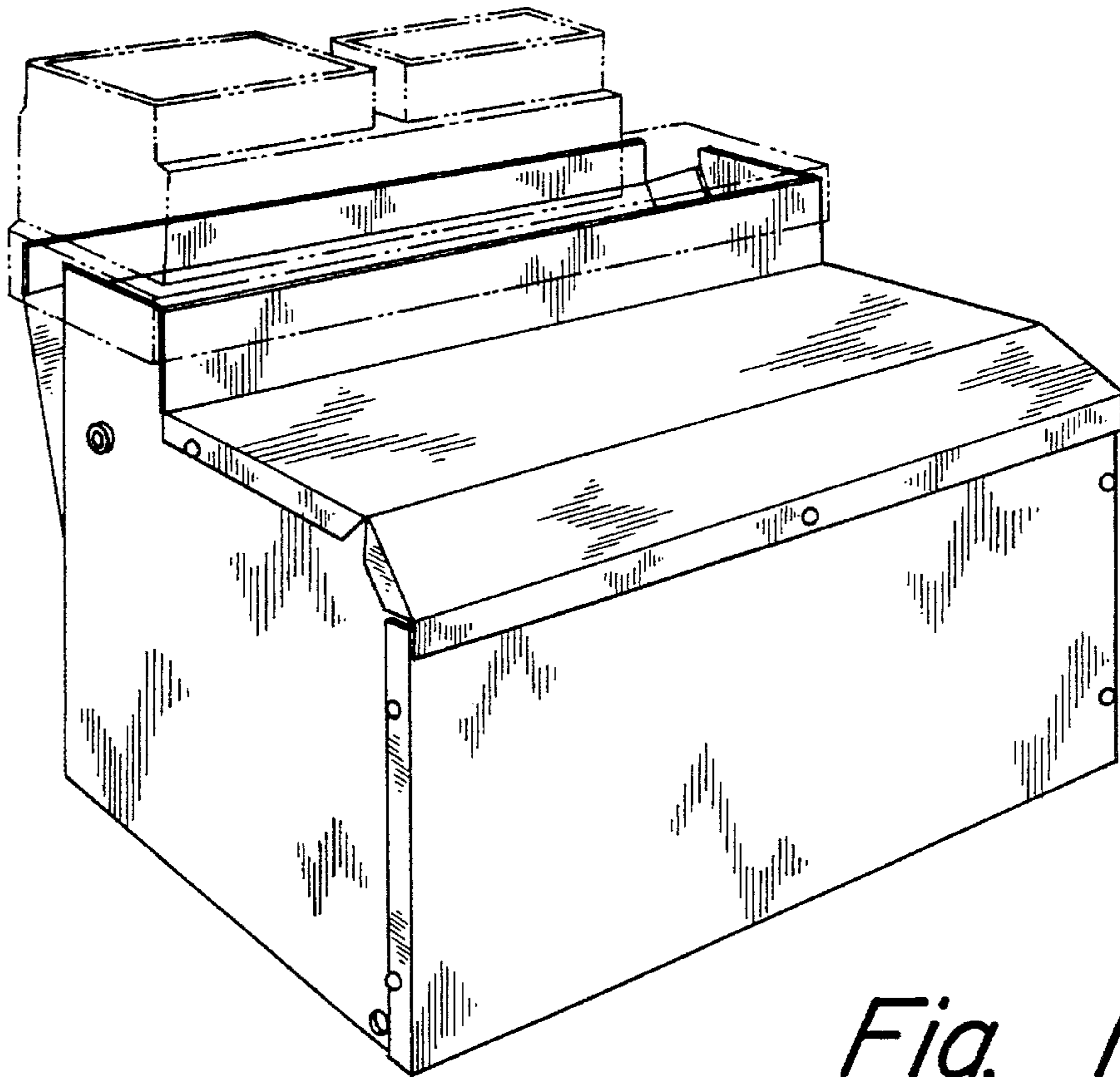
### [56] References Cited

#### U.S. PATENT DOCUMENTS

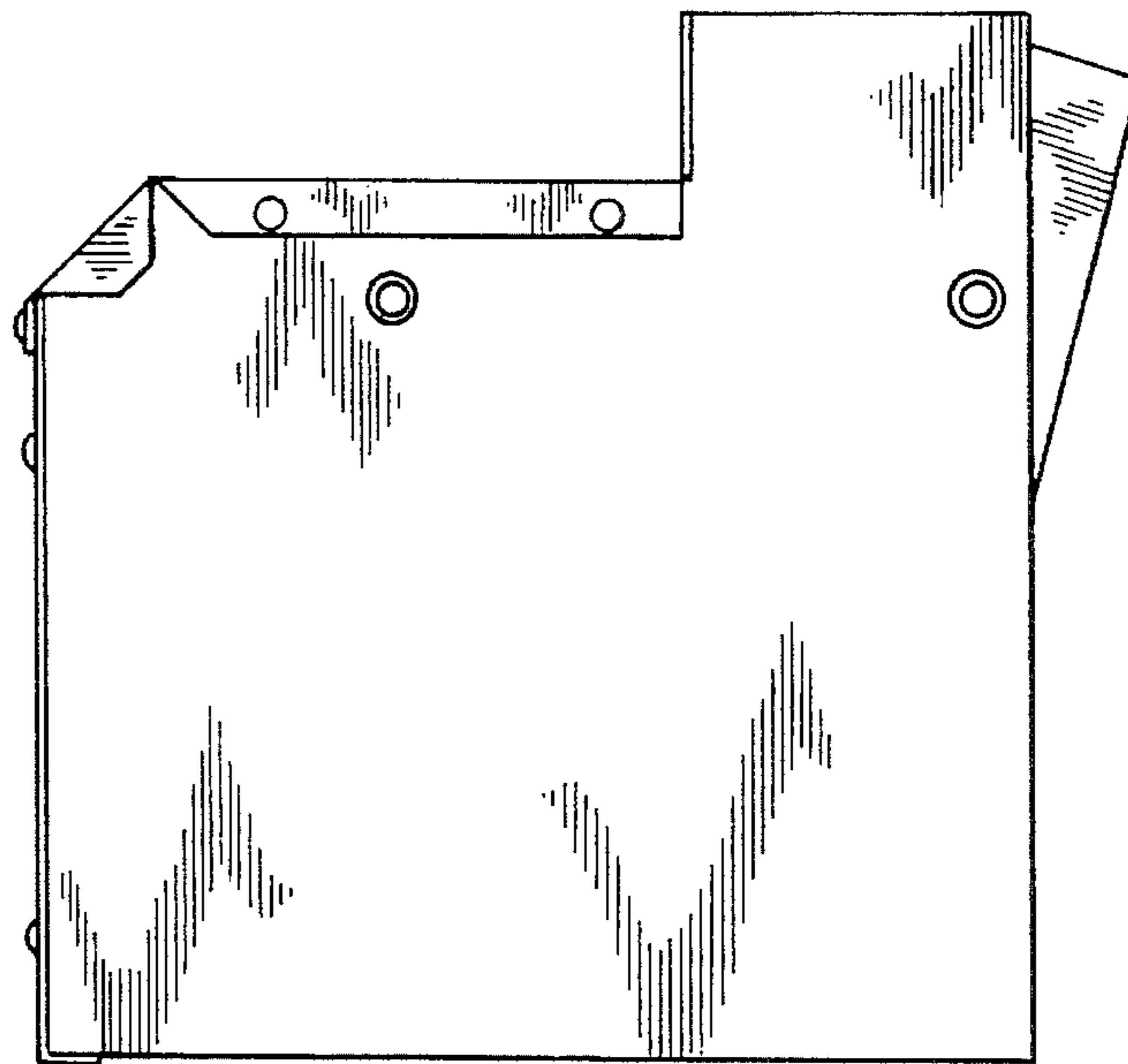
4,413,550	11/1983	Piano .....	454/143
4,674,294	6/1987	D'Agaro .....	62/263
5,116,280	5/1992	Kloster .....	454/137

**1 Claim, 3 Drawing Sheets**

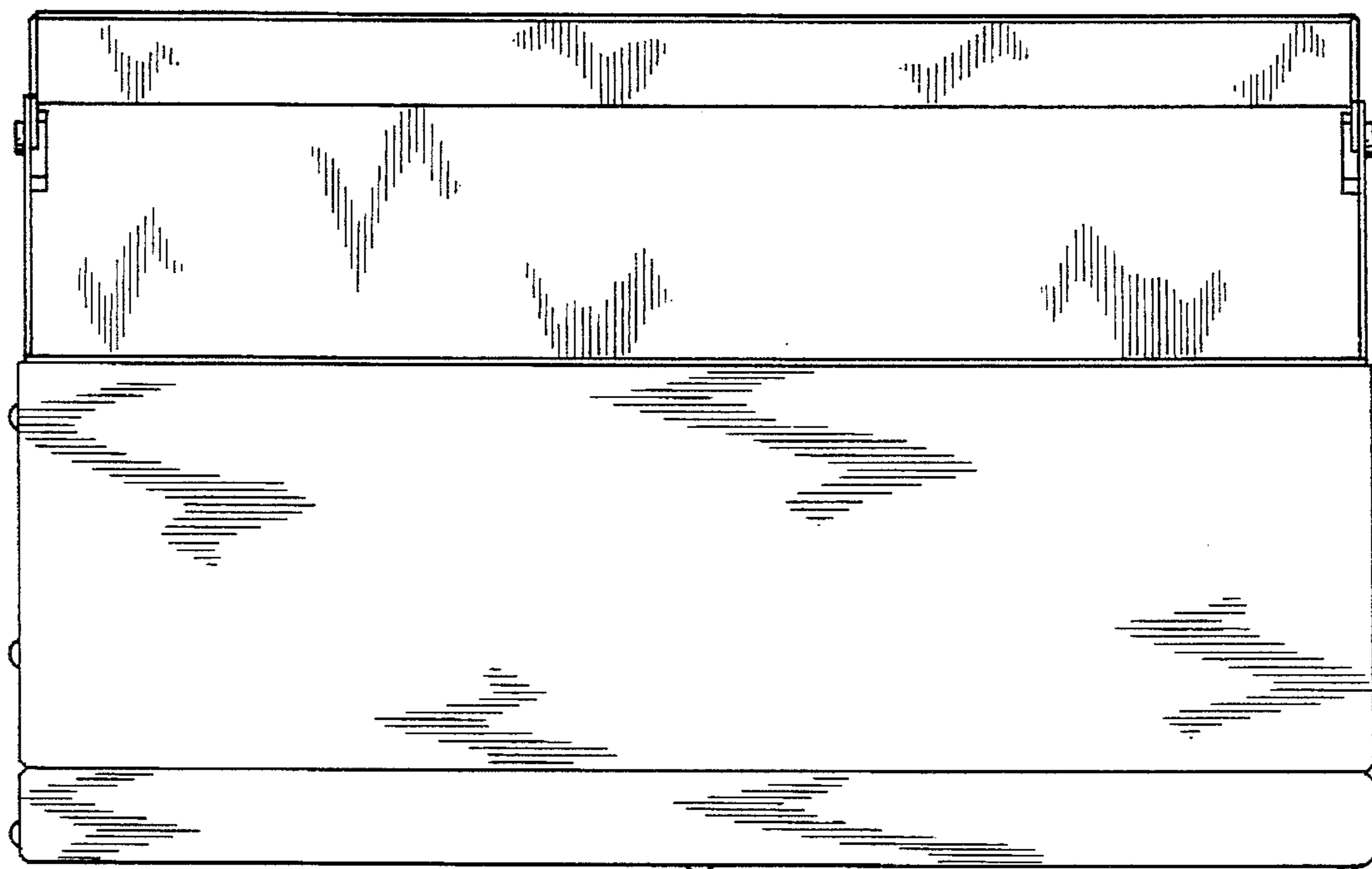




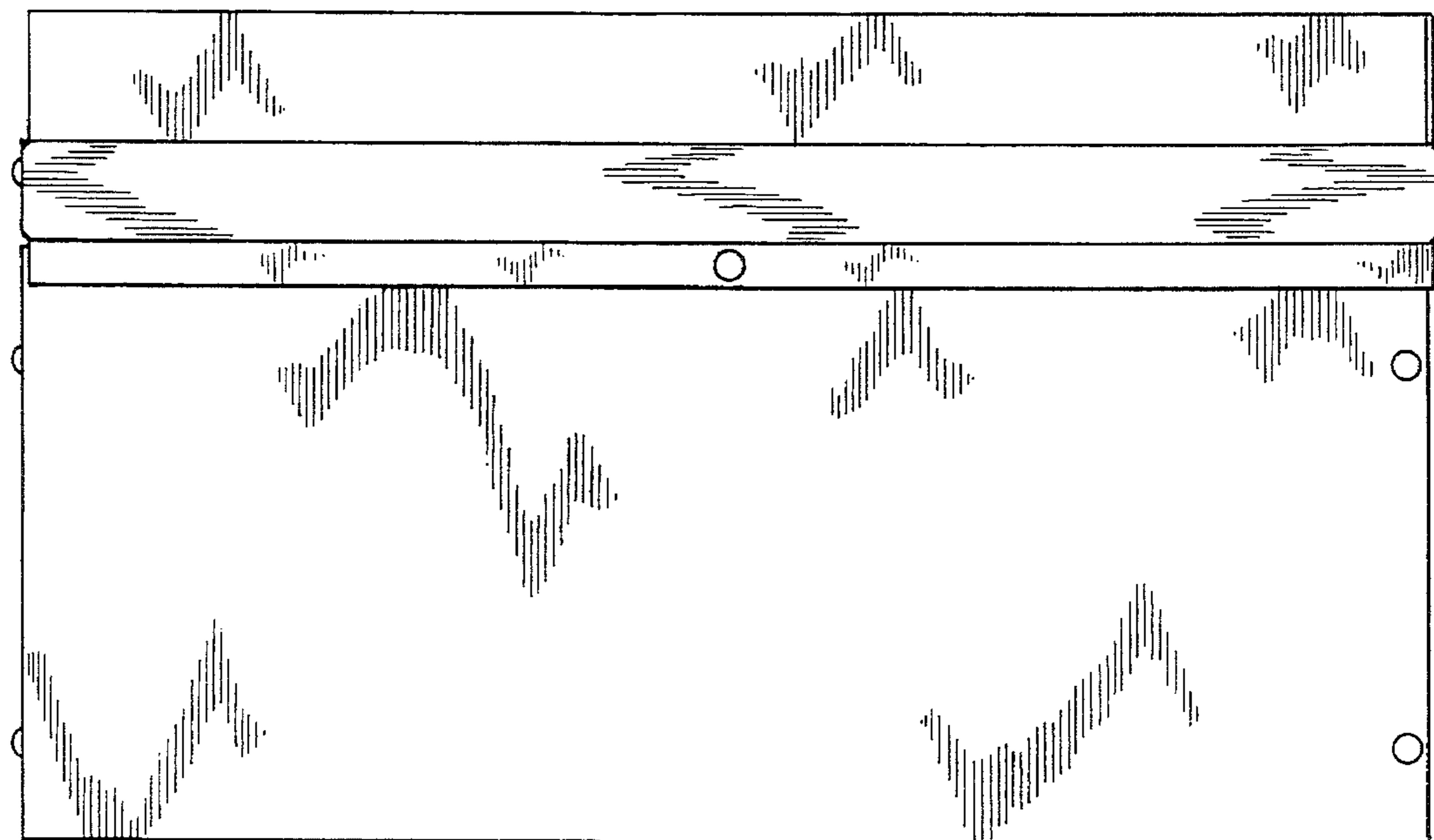
*Fig. 1*



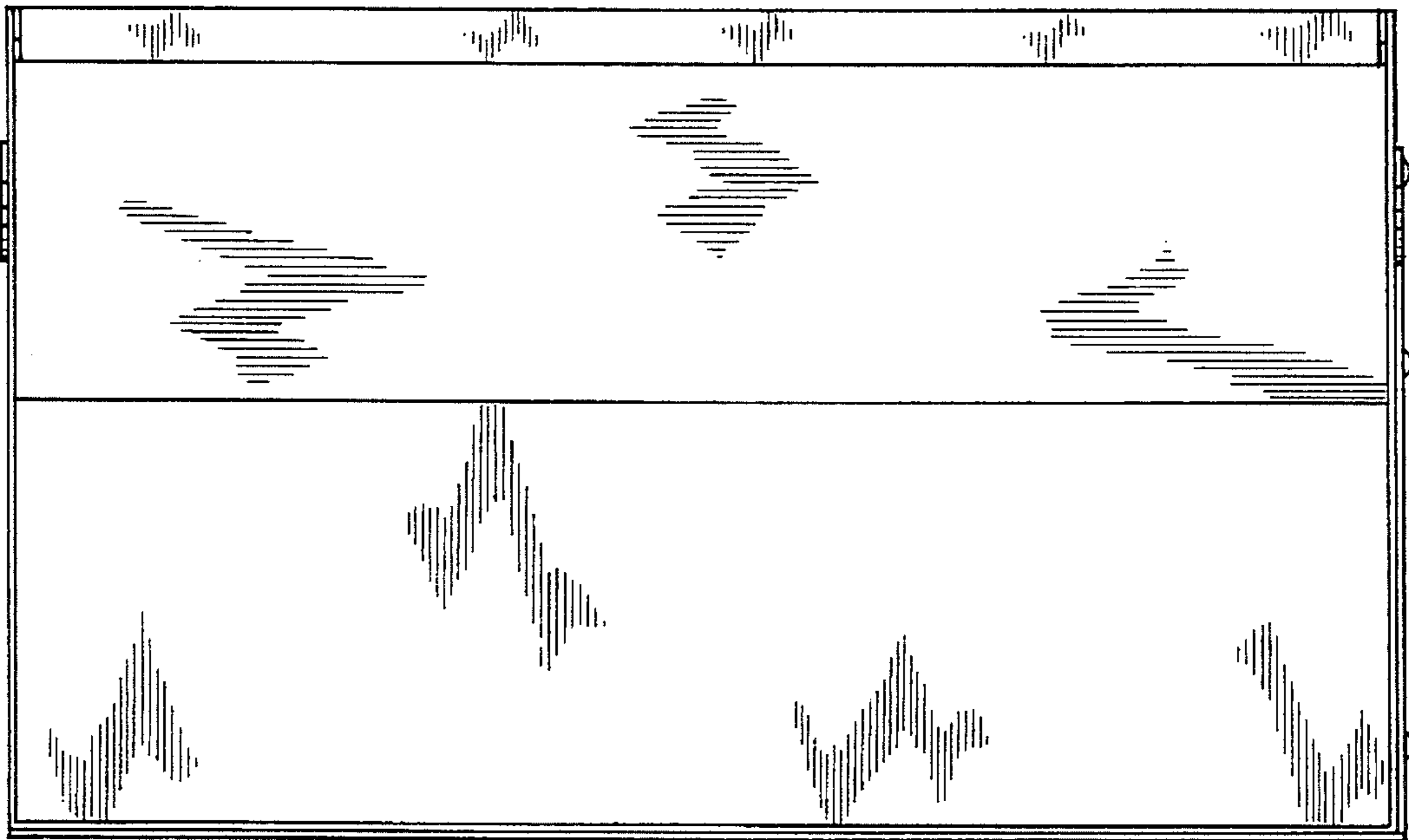
*Fig. 2*



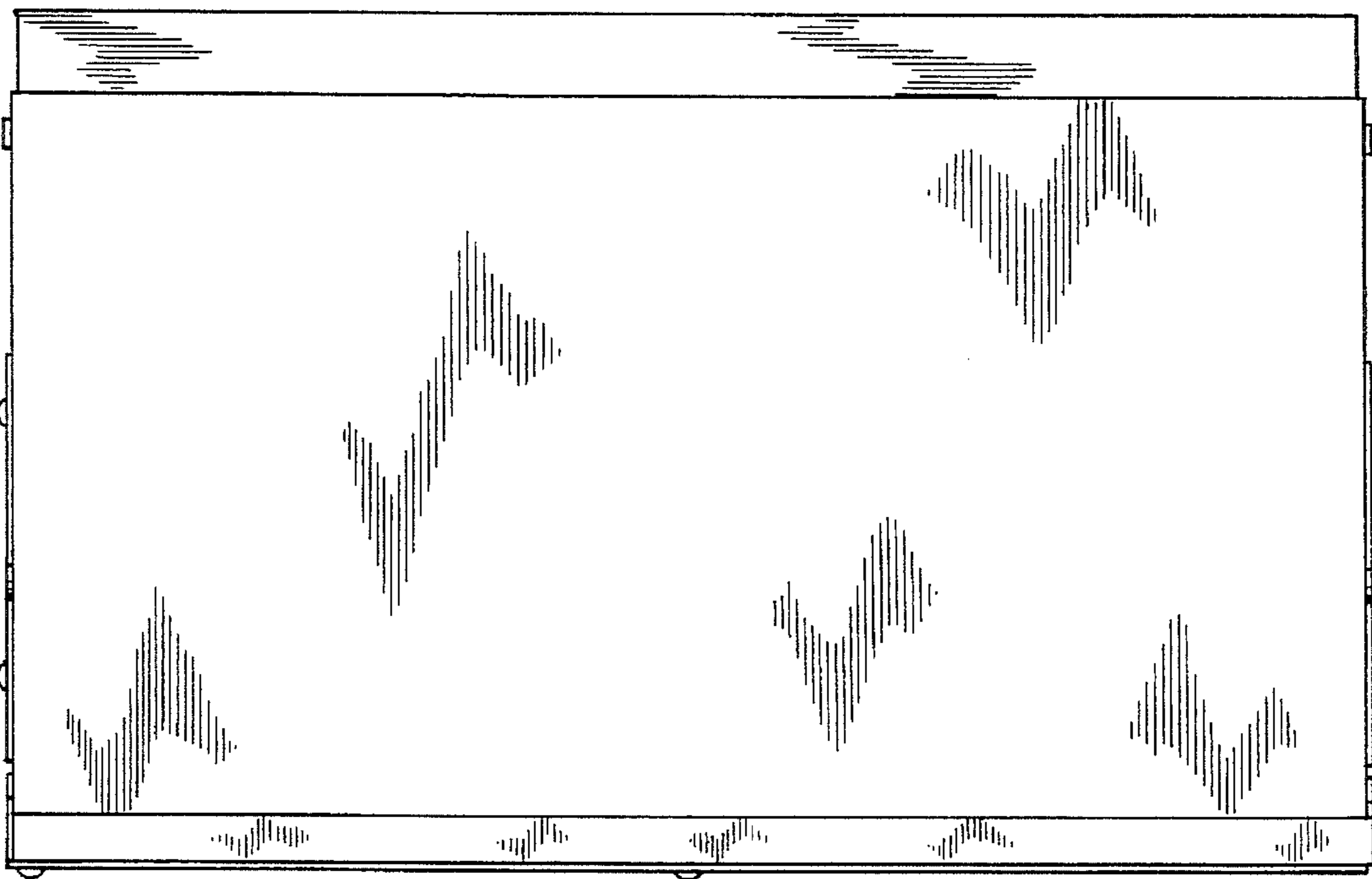
*Fig. 3*



*Fig. 4*



*Fig. 5*



*Fig. 6*