



US00D363761S

United States Patent [19]

[11] Patent Number: **Des. 363,761**

Eggleston et al.

[45] Date of Patent: ****Oct. 31, 1995**

[54] **VALVE ACTUATOR**
[75] Inventors: **Philip W. Eggleston; Randy J. Hall,**
both of Marshalltown, Iowa

4,930,555 6/1990 Rudick 141/98
4,977,922 12/1990 McWilliams 137/269
4,986,299 1/1991 Schultz 137/269
5,275,014 1/1994 Solomon 62/324.1

[73] Assignee: **Fisher Controls International, Inc.,**
Clayton, Mo.

OTHER PUBLICATIONS

Fisher Controls, "Type 657 and 667 Diaphragm Acutators",
Bulletin 61.1:657, Apr. 1992.
Fisher Controls, "470 Series Piston Actuators", Bulletin
61.2:470, Jul. 1993.
Fisher Controls, "Type 585 and 585R Piston Actuators",
Bulletin 61.2:585, Jul. 1993.

[**] Term: **14 Years**

[21] Appl. No.: **23,894**

[22] Filed: **Jun. 2, 1994**

[52] U.S. Cl. **D23/233**

[58] Field of Search **D23/233-237,**
D23/244-249; 137/556; 251/63.5, 331

Primary Examiner—Stella Reid
Assistant Examiner—E. Watterson
Attorney, Agent, or Firm—Marshall, O'Toole, Gerstein,
Murray & Borun

[56] References Cited

U.S. PATENT DOCUMENTS

D. 235,642	7/1925	Erickson	D23/249
D. 286,907	11/1986	Hilpert et al.	D23/249
D. 287,268	12/1986	Hilpert et al.	D23/249
D. 322,657	12/1991	Hartman et al.	D23/233
2,731,534	1/1956	Hansen et al.	219/4
3,084,901	4/1963	Thorburn	251/61
3,516,442	6/1970	Munroe	137/625.66
3,719,199	3/1973	Mentink	137/269
3,719,343	3/1973	Werra	251/61.1
3,958,592	5/1976	Wells et al.	137/315
4,027,692	6/1977	Bouteille et al.	137/270
4,354,425	10/1982	Bruton et al.	137/377 X
4,364,414	12/1982	Bouteille et al.	137/624.14
4,569,378	2/1986	Bergandy	141/266
4,582,082	4/1986	Tosseghini	137/270
4,889,153	12/1989	Zepernick et al.	137/269

[57] CLAIM

The ornamental design for a valve actuator, as shown and described.

DESCRIPTION

FIG. 1 is a perspective view taken from above and to the left of a valve actuator showing our new design;
FIG. 2 is a top plan view thereof;
FIG. 3 is a left side elevational view thereof;
FIG. 4 is a right side elevational view thereof;
FIG. 5 is a front elevational view, the rear elevational view being a mirror image thereof; and,
FIG. 6 is a bottom view thereof.

1 Claim, 2 Drawing Sheets

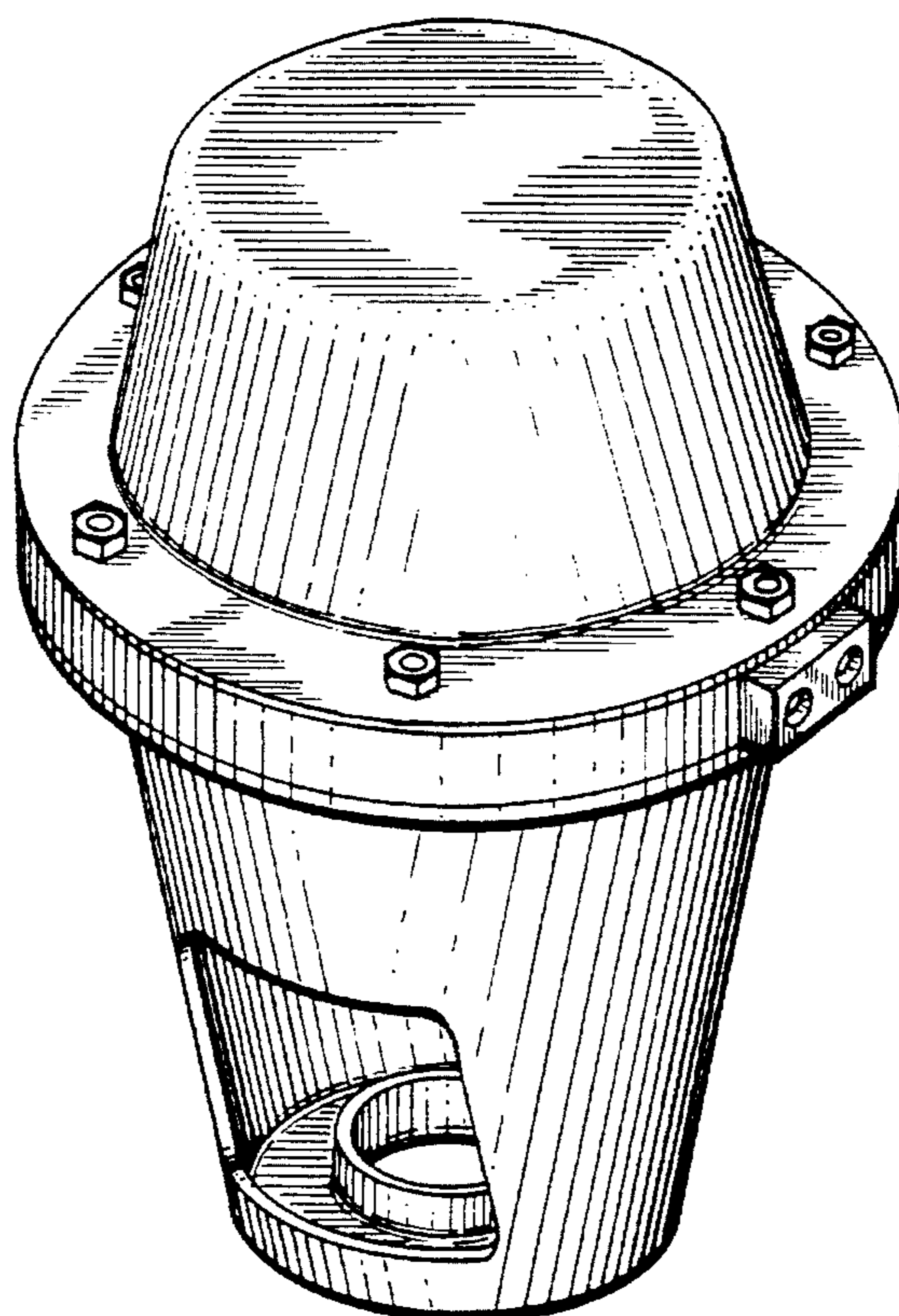

FIG.1

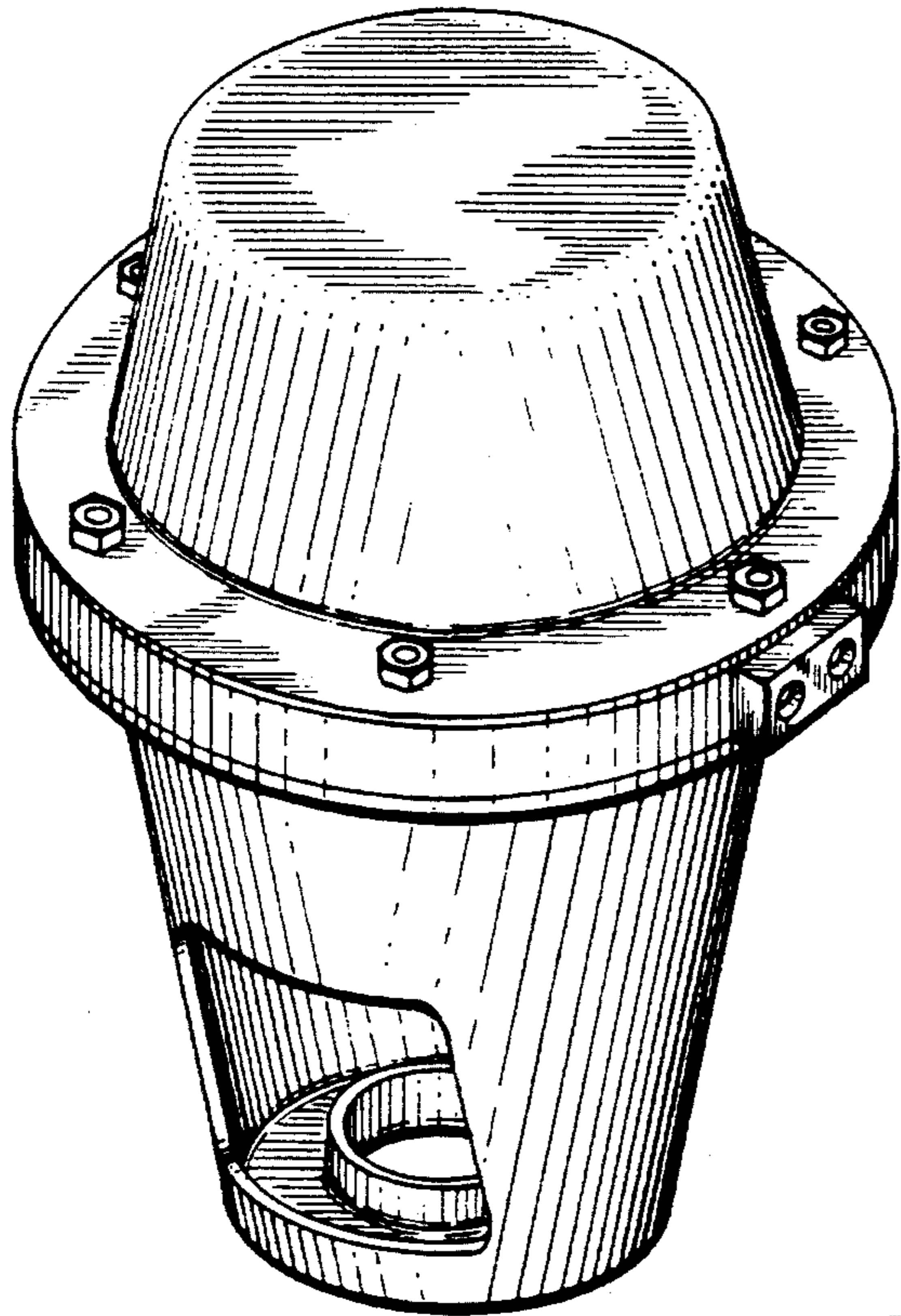

FIG.2

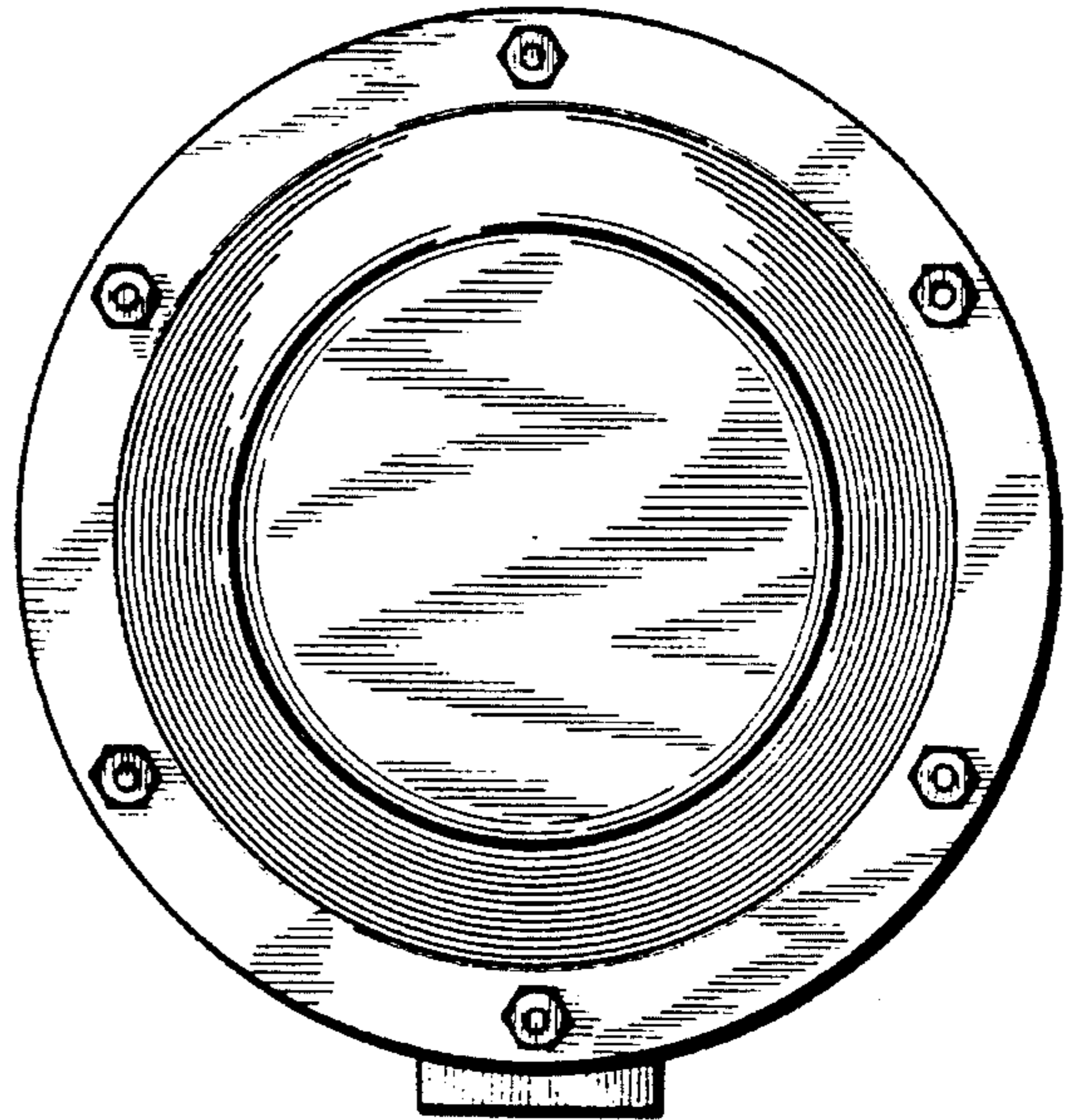

FIG.3

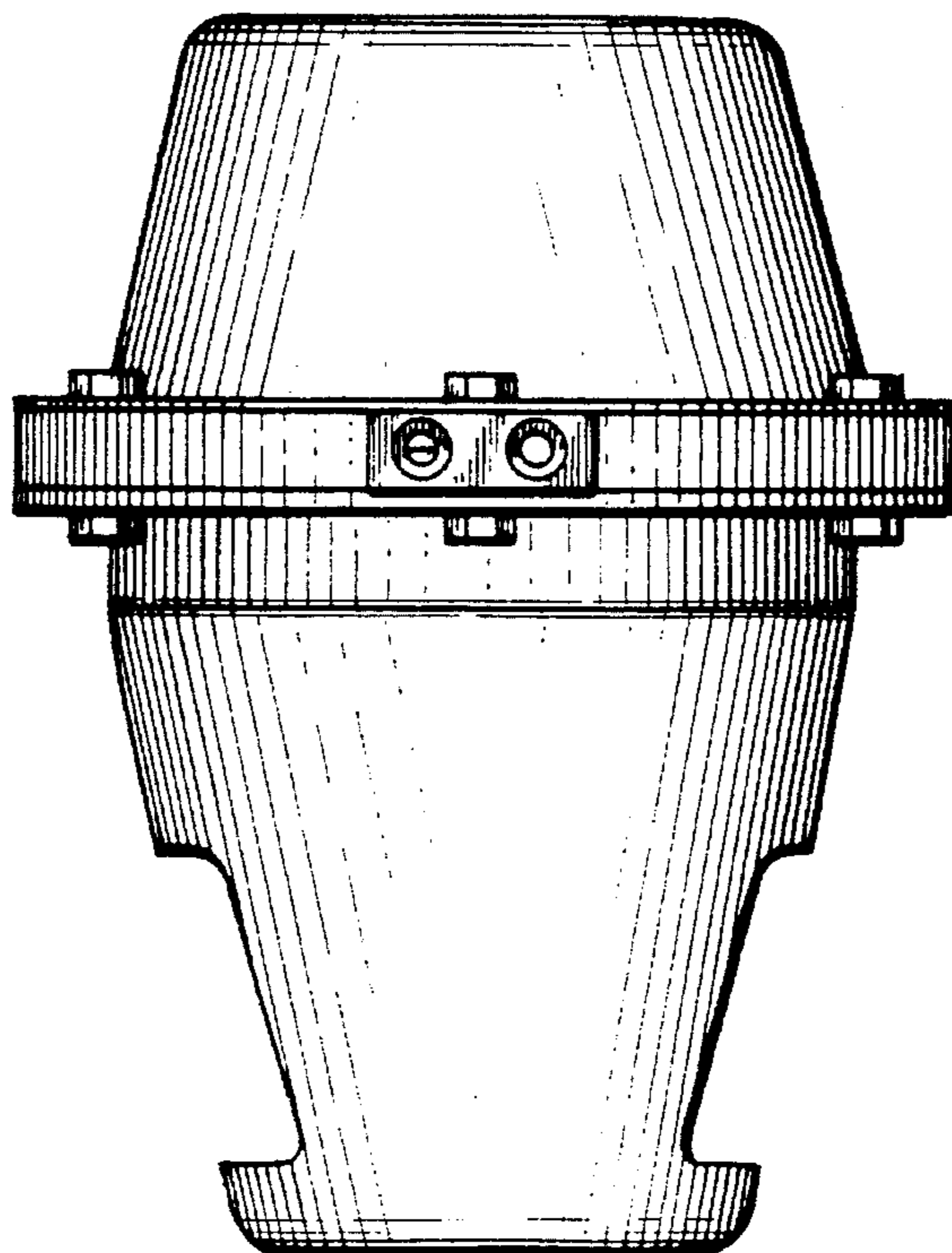

FIG. 4

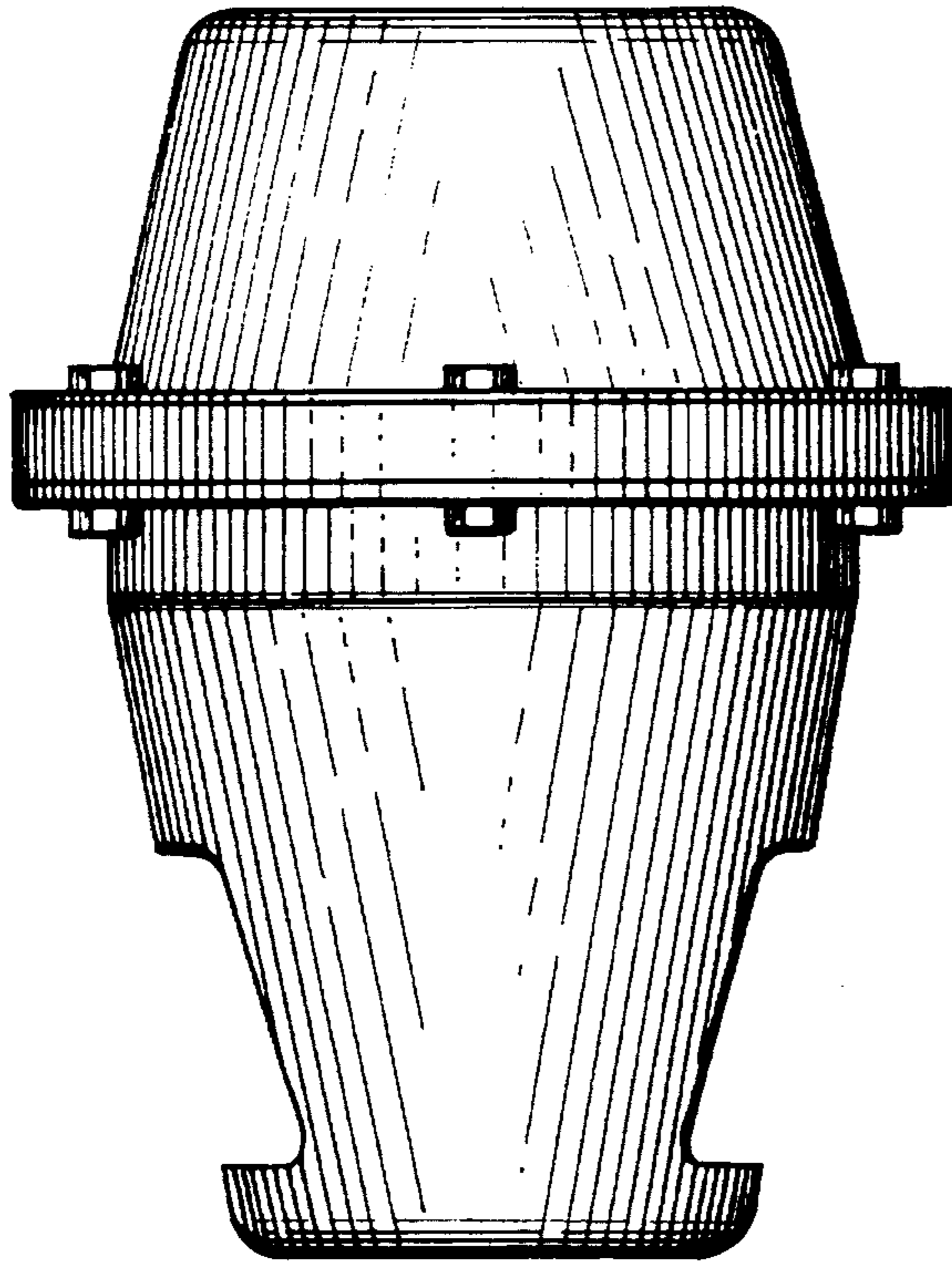

FIG. 5

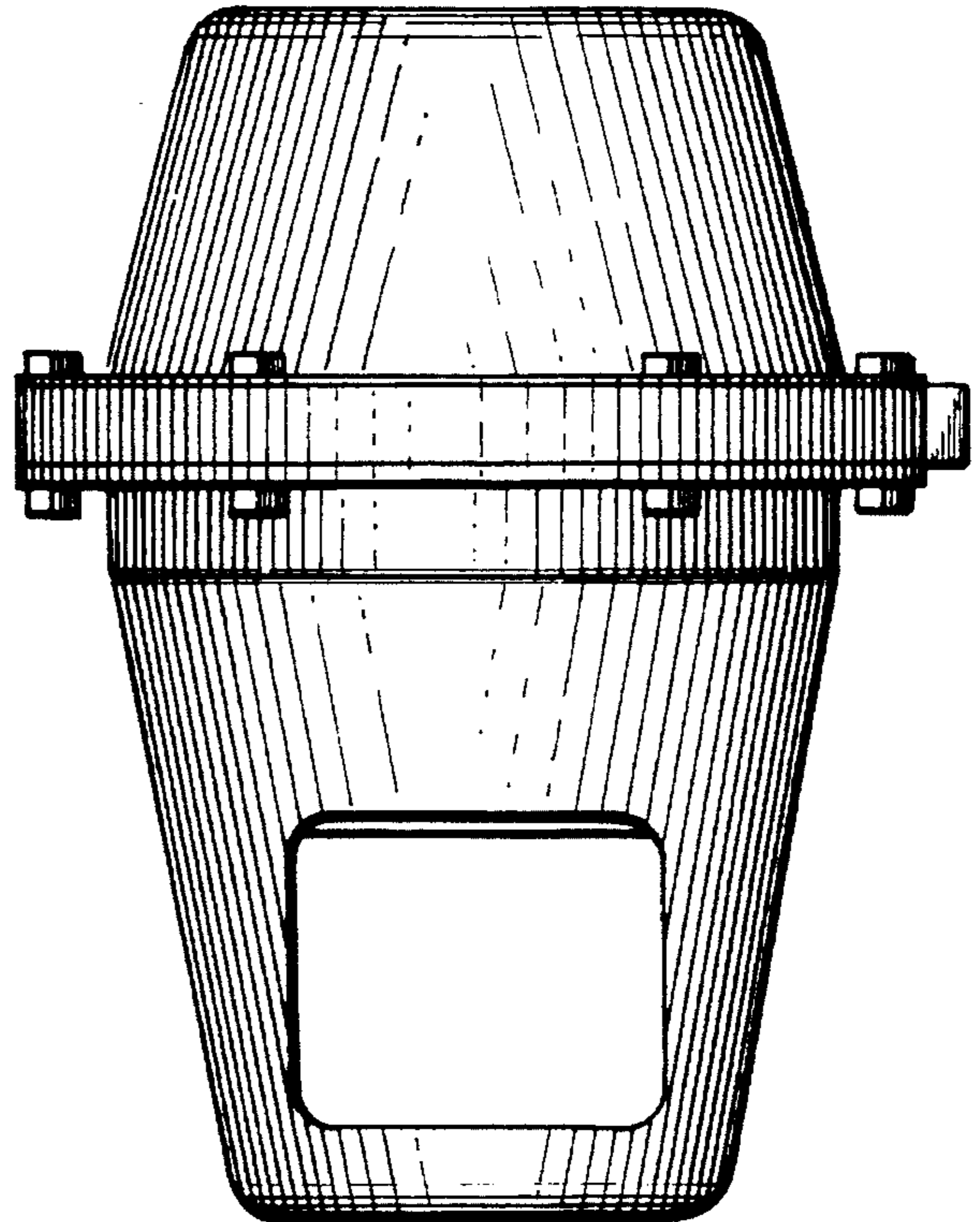

FIG. 6

