



US00D363701S

United States Patent [19]

[11] Patent Number: **Des. 363,701**

Paquette et al.

[45] Date of Patent: ****Oct. 31, 1995**

[54] SHELF SUPPORT AND ELECTRICAL CABLE MANAGEMENT STRUCTURE

Attorney, Agent, or Firm—Quarles & Brady

[75] Inventors: **Edmund T. Paquette**, Shrewsbury;
Donald B. McCallum, Douglas, both
of Mass.

[57] CLAIM

The ornamental design for a shelf support and electrical cable management structure, as shown and described.

[73] Assignee: **Wright Line, Inc.**, Worcester, Mass.

DESCRIPTION

[**] Term: **14 Years**

[21] Appl. No.: **38,586**

[22] Filed: **May 8, 1995**

FIG. 1 is a perspective view taken from the top, front and left side of a shelf support and electrical cable management structure embodying our new design;

FIG. 2 is a front elevational view thereof;

FIG. 3 is a right side elevational view, the left side being the mirror image of the right side;

FIG. 4 is a top plan view thereof;

FIG. 5 is a rear elevational view thereof;

FIG. 6 is a perspective view taken from the top, front and left side of a second embodiment of our new design;

FIG. 7 is a front elevational view thereof;

FIG. 8 is a right side elevational view thereof, the left side being the mirror image of the right side;

FIG. 9 is a top plan view thereof;

FIG. 10 is a rear elevational view thereof;

FIG. 11 is a perspective view taken from the top, front and left side of a third embodiment of our new design;

FIG. 12 is a front elevational view of the embodiment of FIG. 11;

FIG. 13 is a right side elevational view thereof, the left side being the mirror image of the right side;

FIG. 14 is a top plan view thereof;

FIG. 15 is a rear elevational view thereof;

FIG. 16 is a perspective view taken from the top, front and left side of a fourth embodiment of our design, of which the front elevational view is FIG. 7 and the rear elevational view is FIG. 10;

FIG. 17 is a right side elevational view of the embodiment of FIG. 16, the left side being the mirror image of the right side;

FIG. 18 is a top plan view thereof;

FIG. 19 is an enlarged view of the detail circumscribed by line 19—19 of FIG. 11; and,

FIG. 20 is an enlarged view of the detail circumscribed by line 20—20 in FIG. 10.

The broken lines in FIGS. 1, 2, 5, 6, 7, 10, 11, 12, 15 and 16 represent a continuous array of the opening shown with which they are aligned.

Related U.S. Application Data

[63] Continuation of Ser. No. 17,310, Jan. 10, 1994.

[52] U.S. Cl. **D13/154**; D6/499; D6/484

[58] Field of Search D13/154, 184;
D8/356, 381; D6/484, 491, 496, 499; D14/114;
361/826; 312/223.2, 223.3, 223.6; 211/26,
187; 174/48

[56] References Cited

U.S. PATENT DOCUMENTS

D. 243,891	4/1977	Snyder	D6/24
D. 245,301	8/1977	Brandenfels	D6/157
D. 288,509	3/1987	van de Oudeweetering	D6/499 X
D. 305,839	2/1990	Howard et al.	D6/462
D. 316,723	5/1991	Ng et al.	D6/484 X
D. 332,887	2/1993	Fjello-Jensen	D6/496

(List continued on next page.)

OTHER PUBLICATIONS

Dividing walls on p. 6 of *Herman Miller Ethospace Interiors catalog* ©1986.

Panel stations on p. 93 of *Jacobs Gardner* 1988 catalog.

Computer furniture on p. 76 of *Jacobs Gardner* 1988 catalog.

Computer furniture on p. 78 of *Jacobs Gardner* 1988 catalog.

Pp. 18, 19, 23, 35 and 36 from a *Wright Line Direct Order Edition Catalog* dated Winter 1991.

Primary Examiner—Joel Sincavage

1 Claim, 11 Drawing Sheets

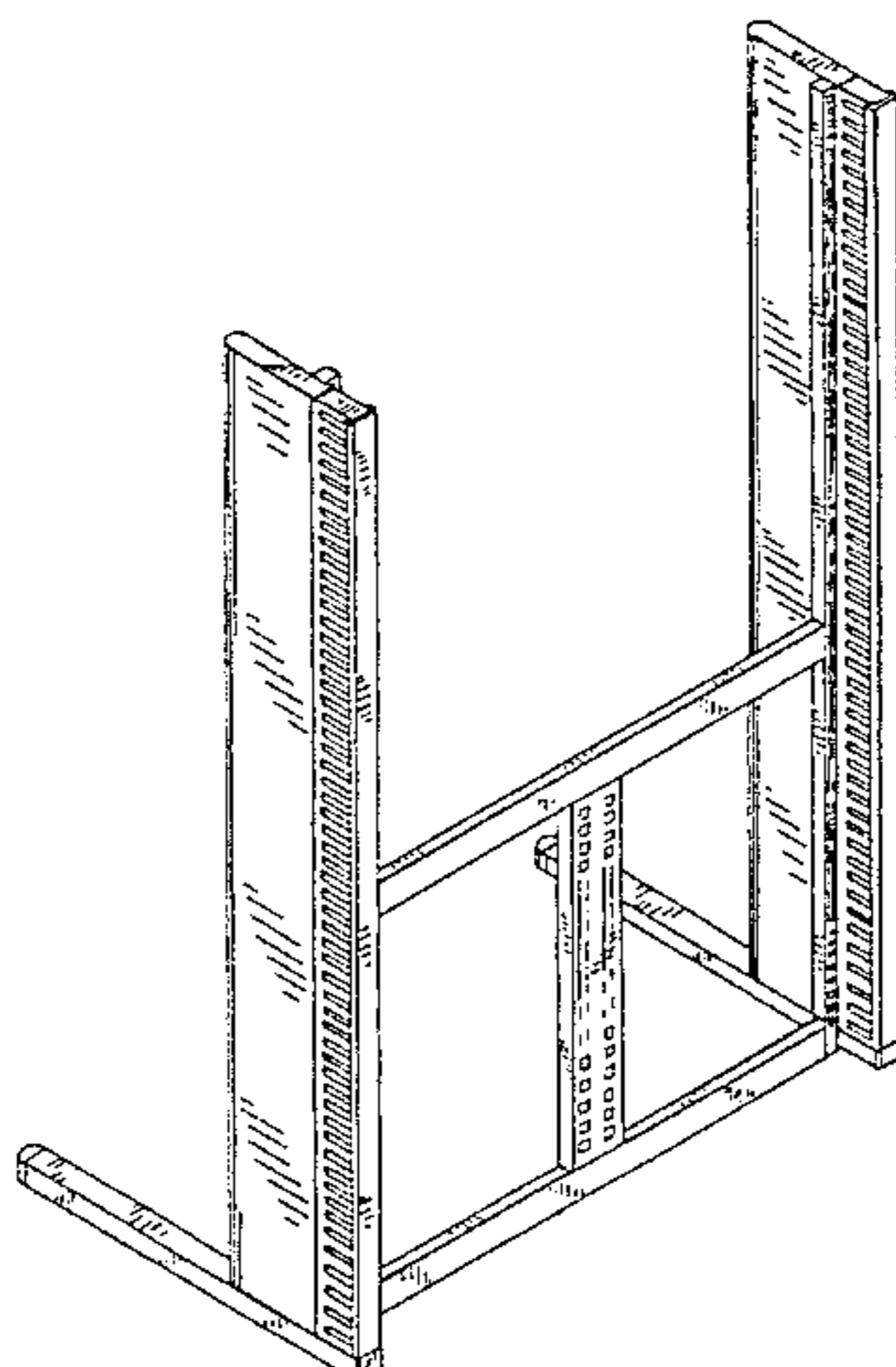

Des. 363,701

Page 2

U.S. PATENT DOCUMENTS			
D. 338,577	8/1993	Vonhausen	D6/484
2,363,327	11/1944	Hodgkins et al.	175/371
3,657,608	4/1972	Leone et al.	317/118
3,794,281	2/1974	Munsey	211/187 X
4,278,834	7/1981	Boundy	174/48
4,641,754	2/1987	Hebel et al.	211/26
4,715,502	12/1987	Salmon	211/26
5,277,006	1/1994	Ruster	174/48 X
5,284,254	2/1994	Rinderer	211/26
5,357,874	10/1994	Palmer	312/223.3 X

FIG. 1

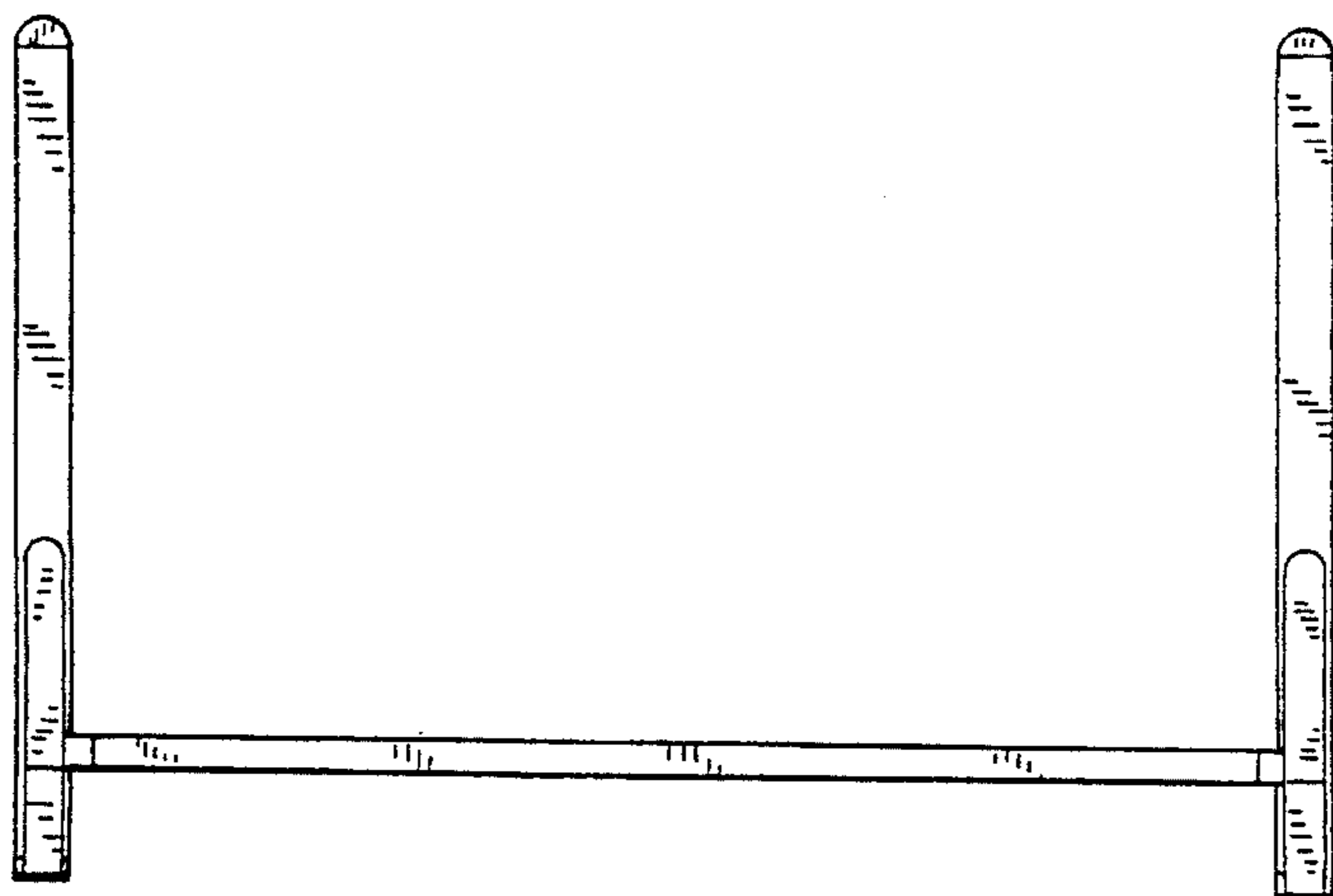
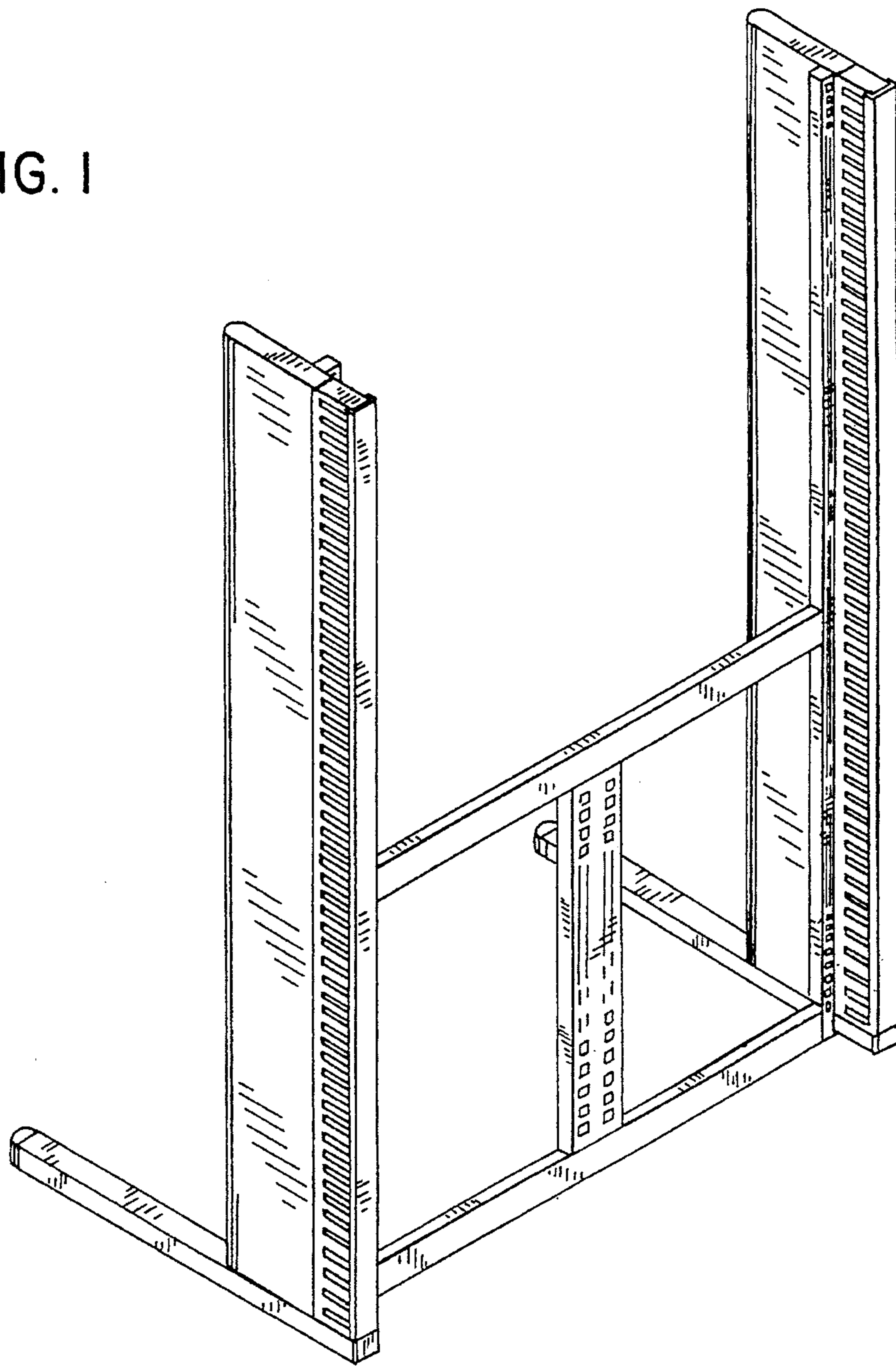

FIG. 4

FIG. 2

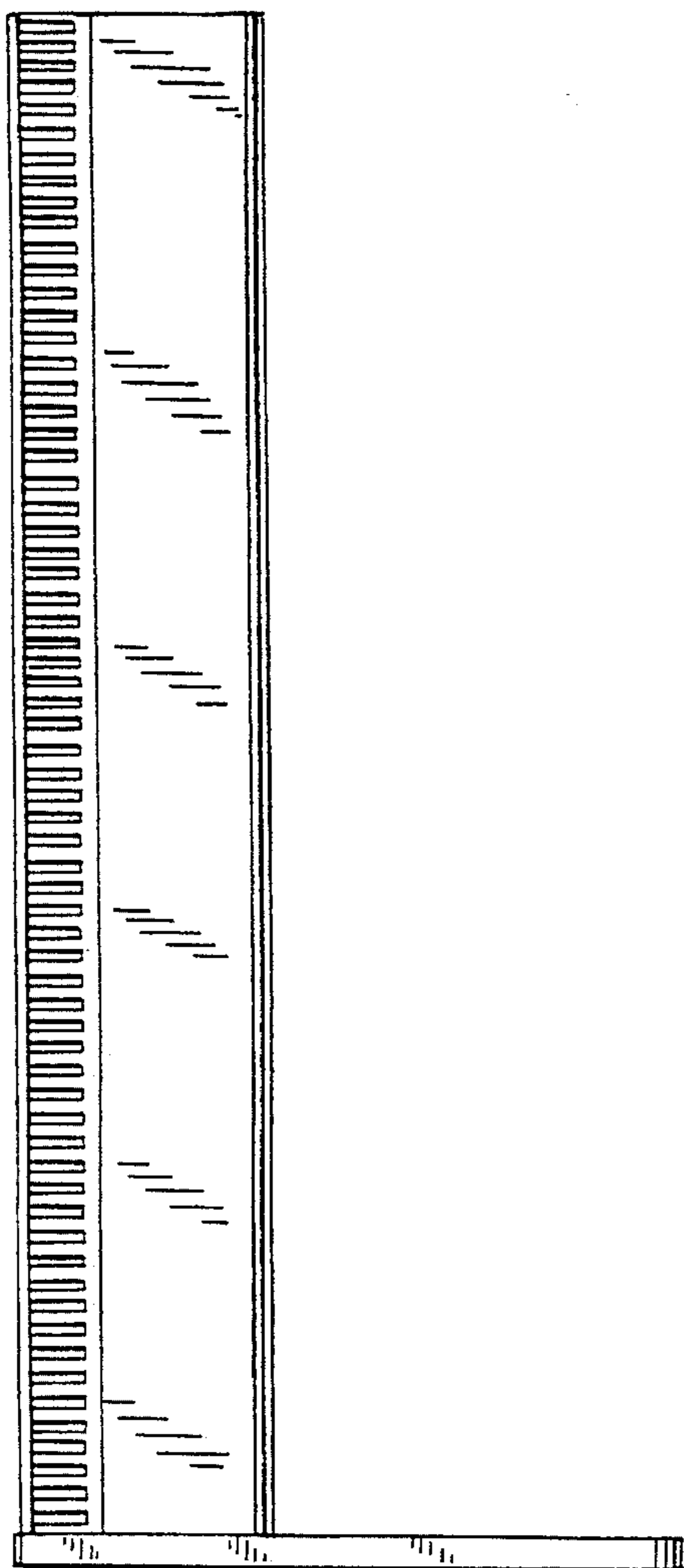
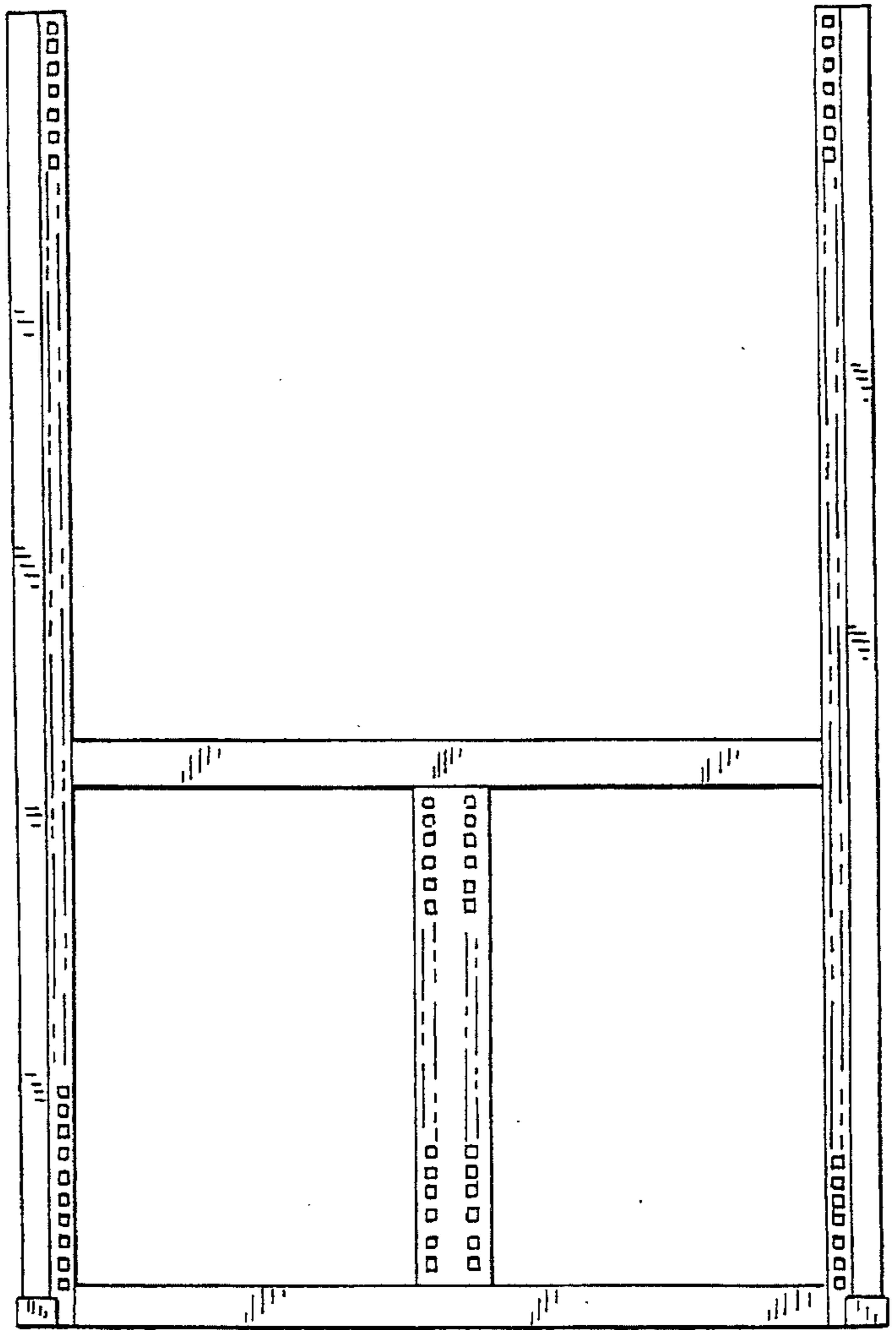

FIG. 3

FIG. 5

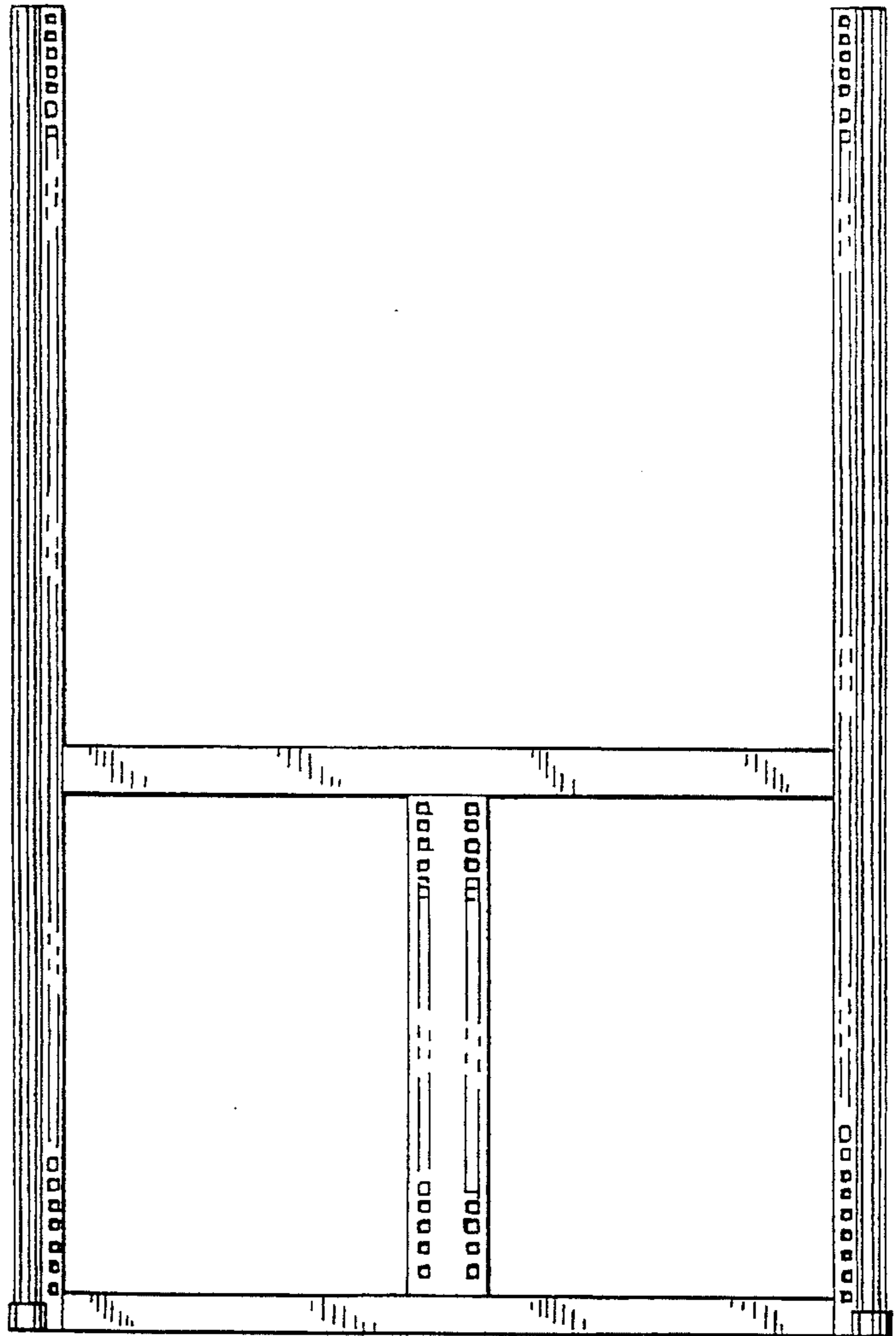

FIG. 8

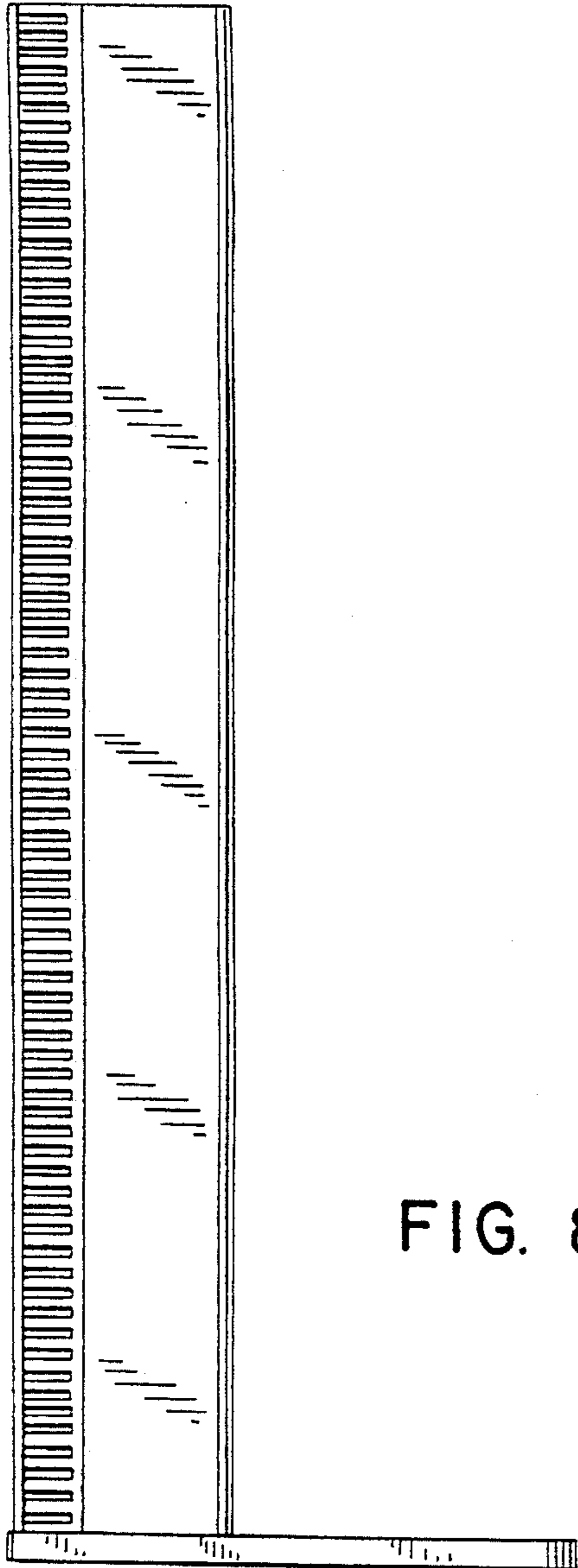

FIG. 6

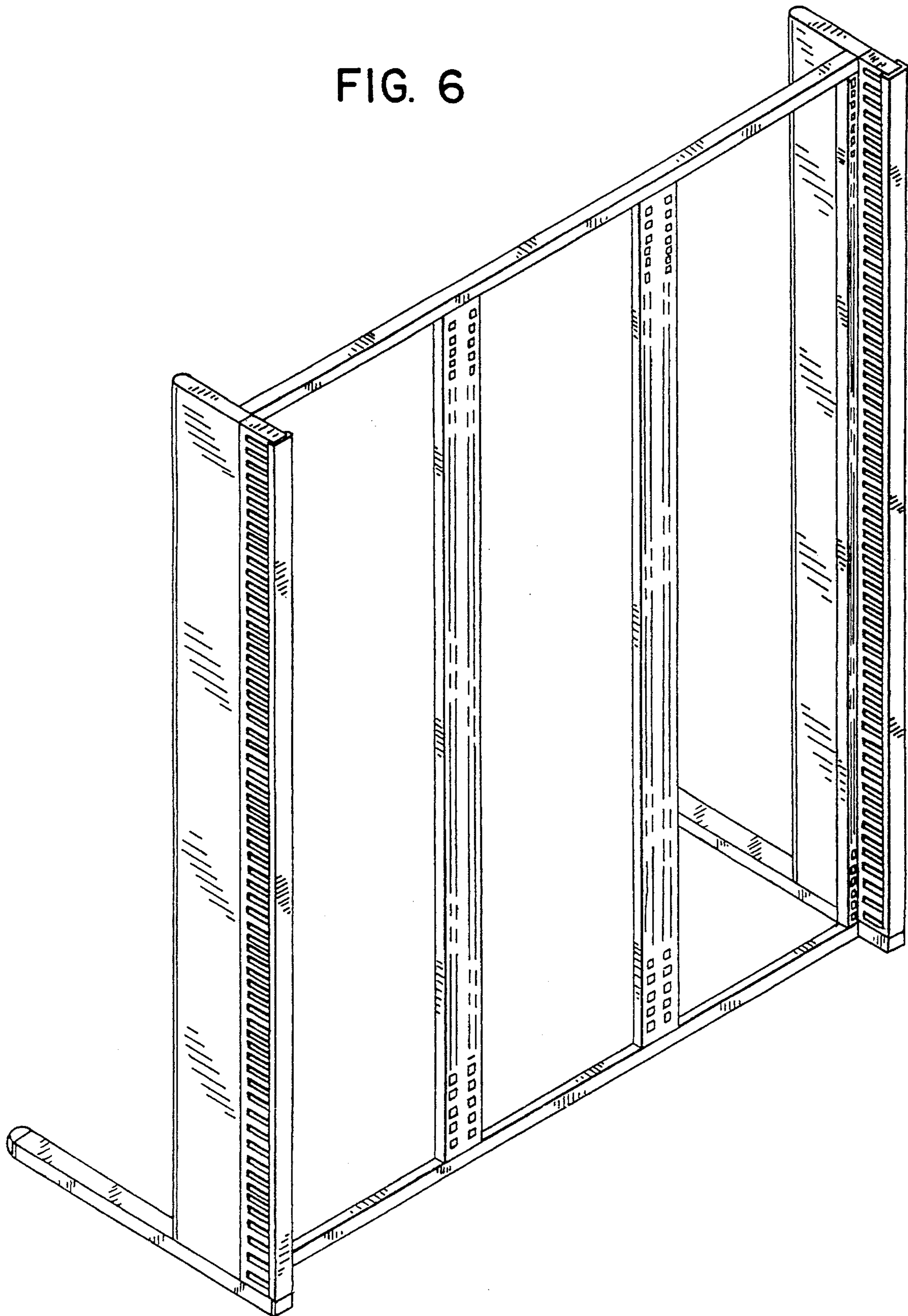

FIG. 7

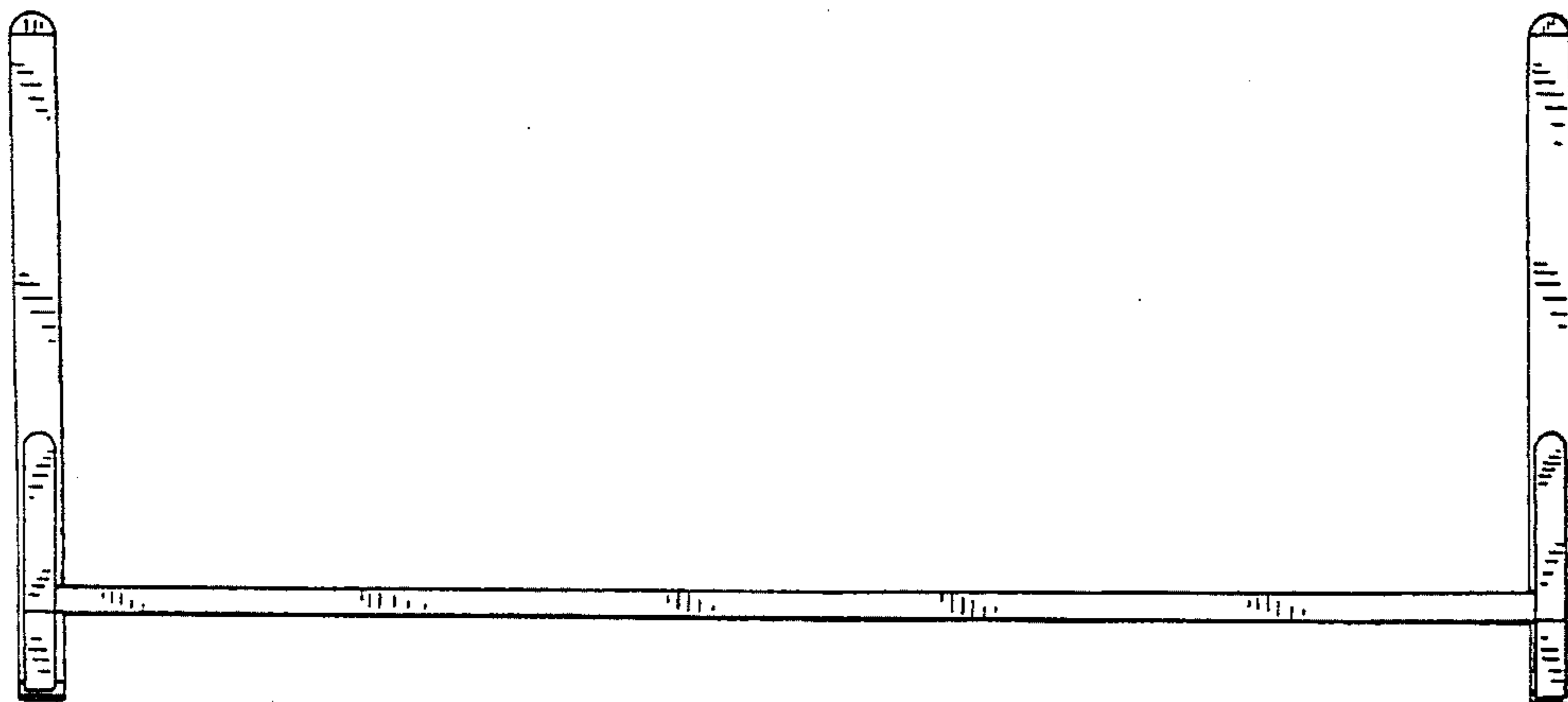
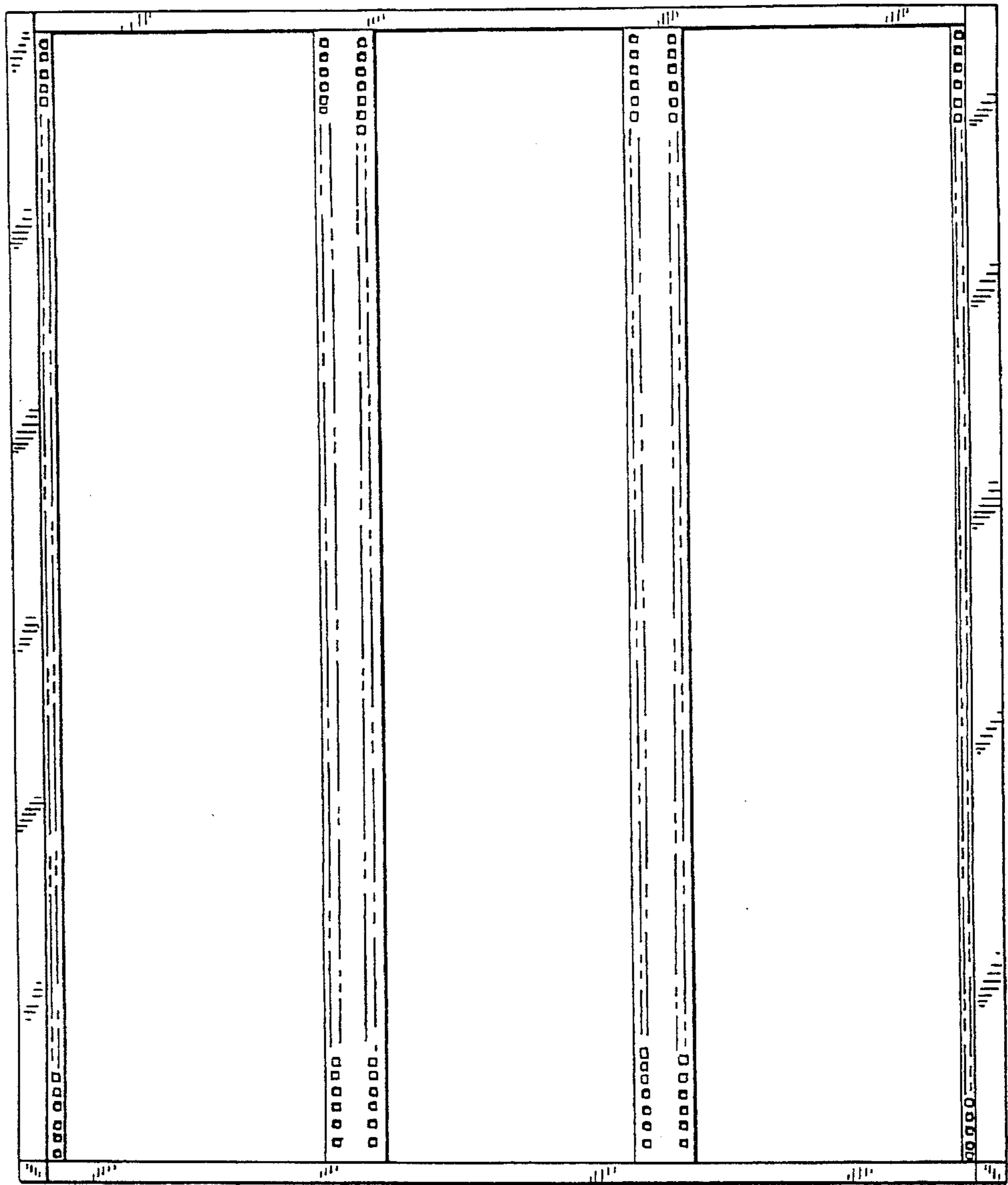

FIG. 9

FIG. 10

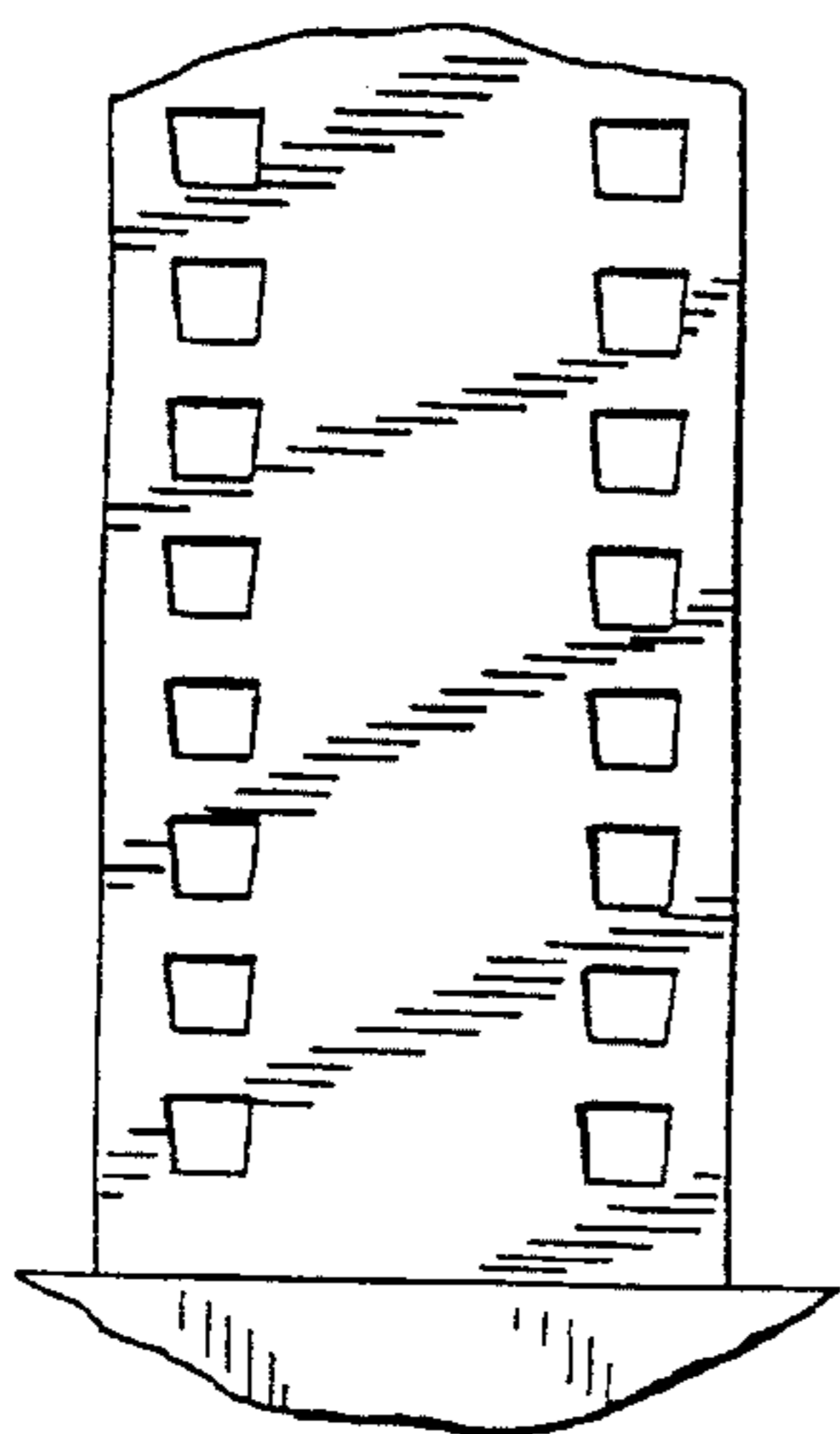
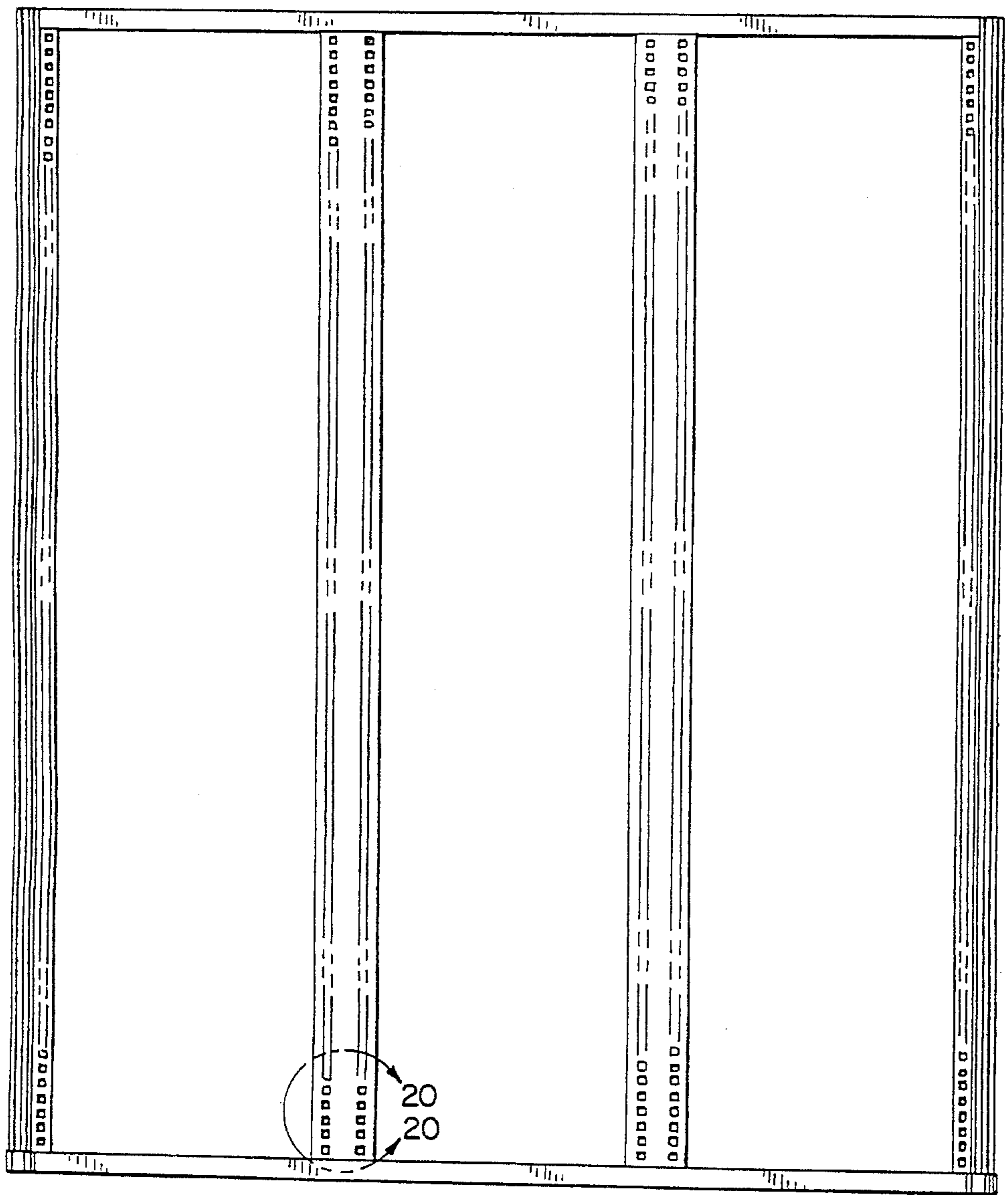

FIG. 20

FIG. II

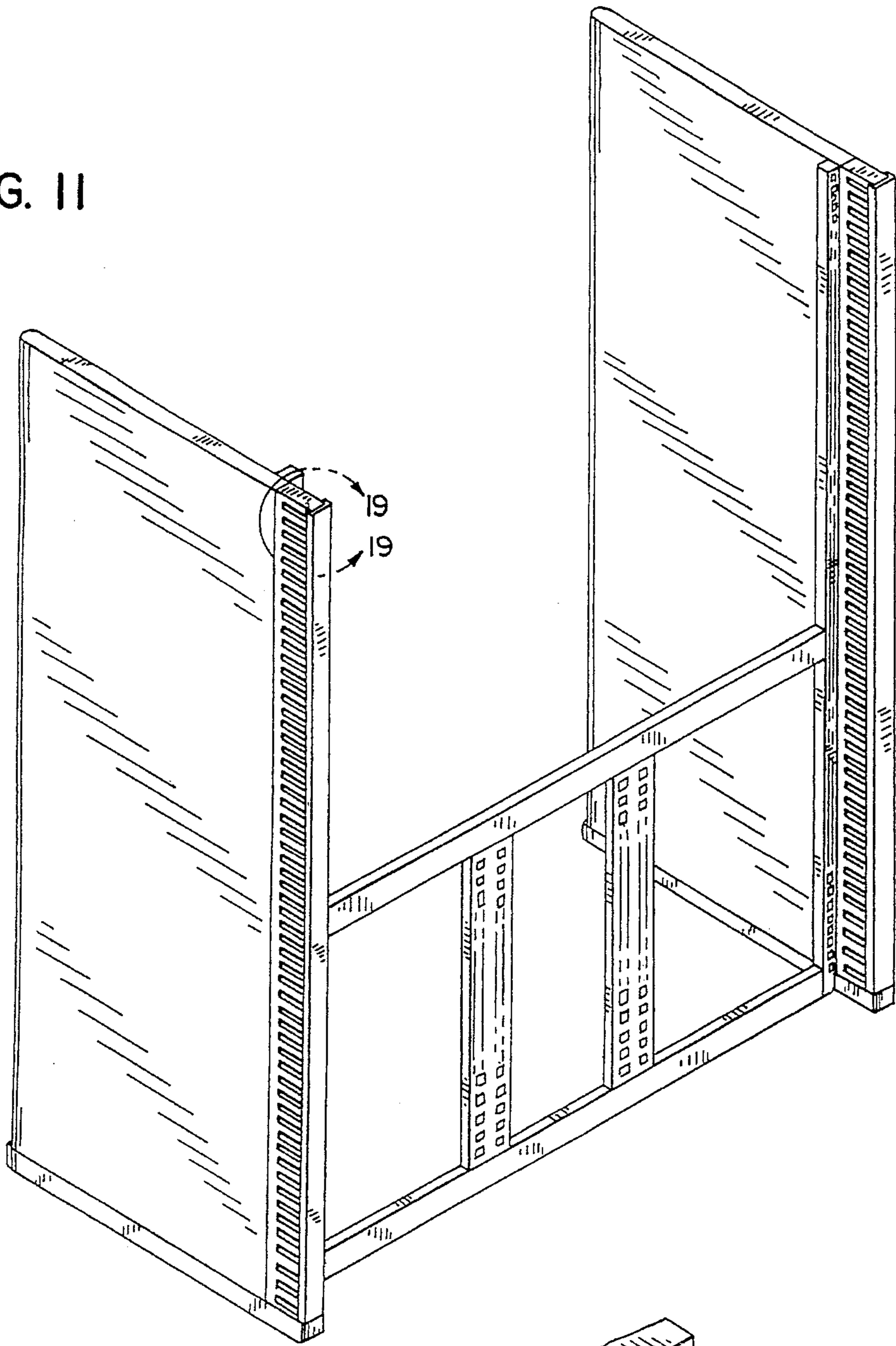

FIG. 19

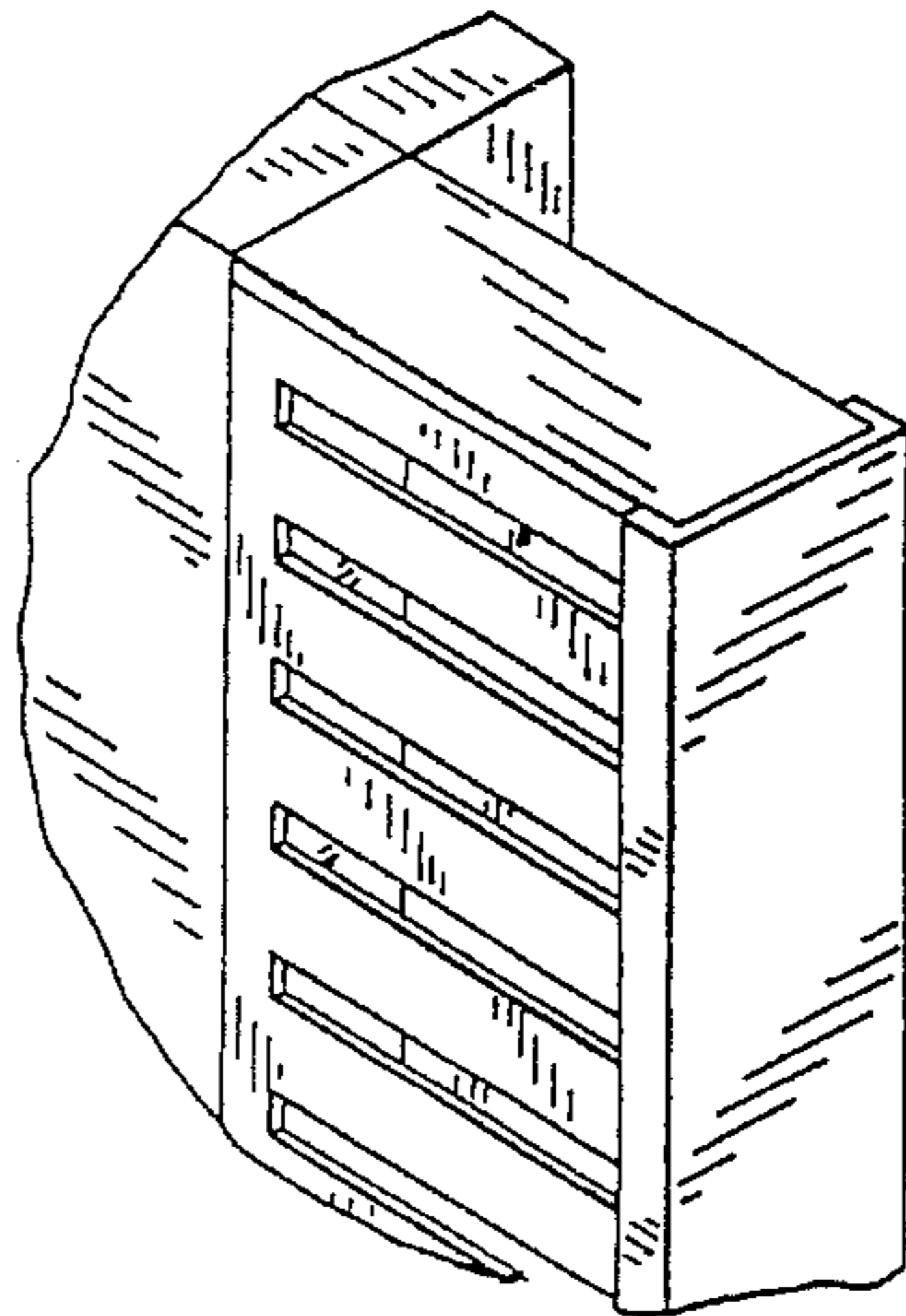

FIG. 13

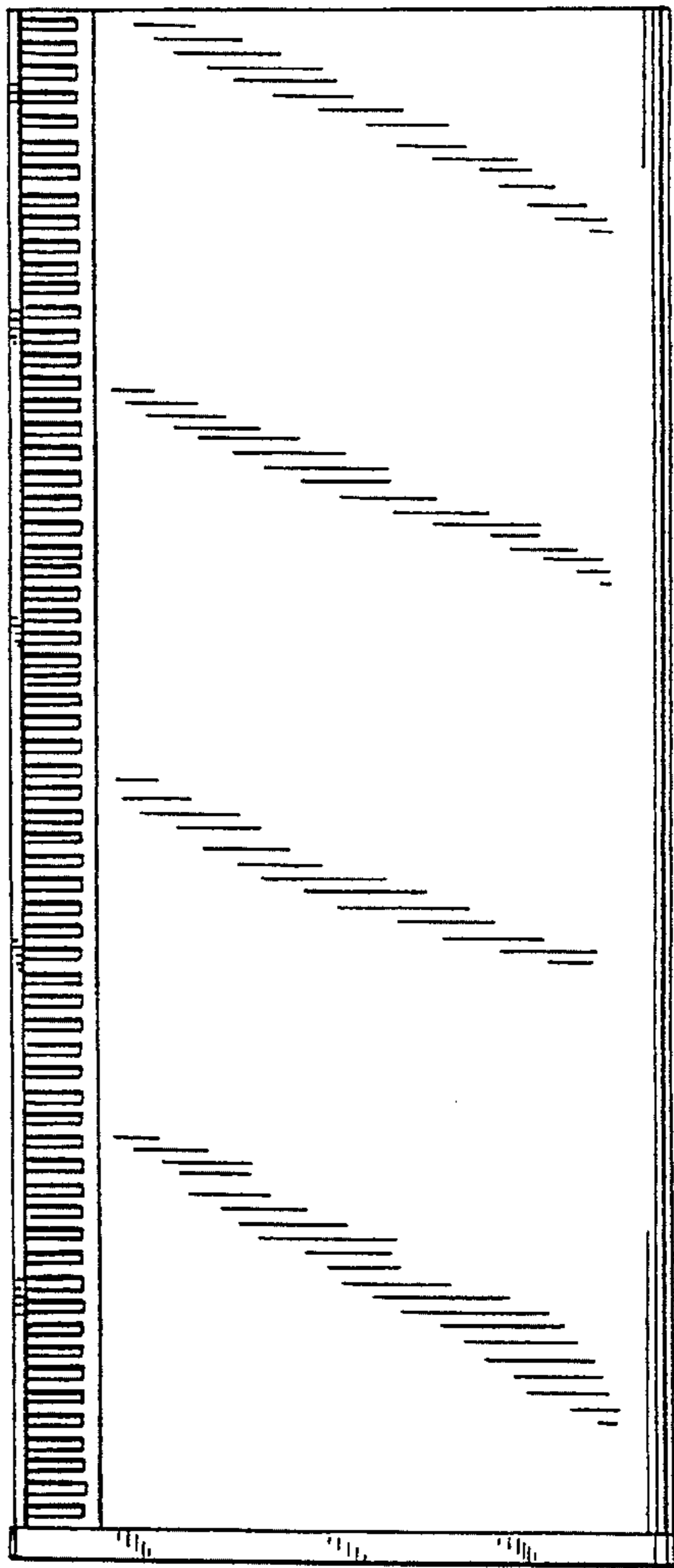

FIG. 12

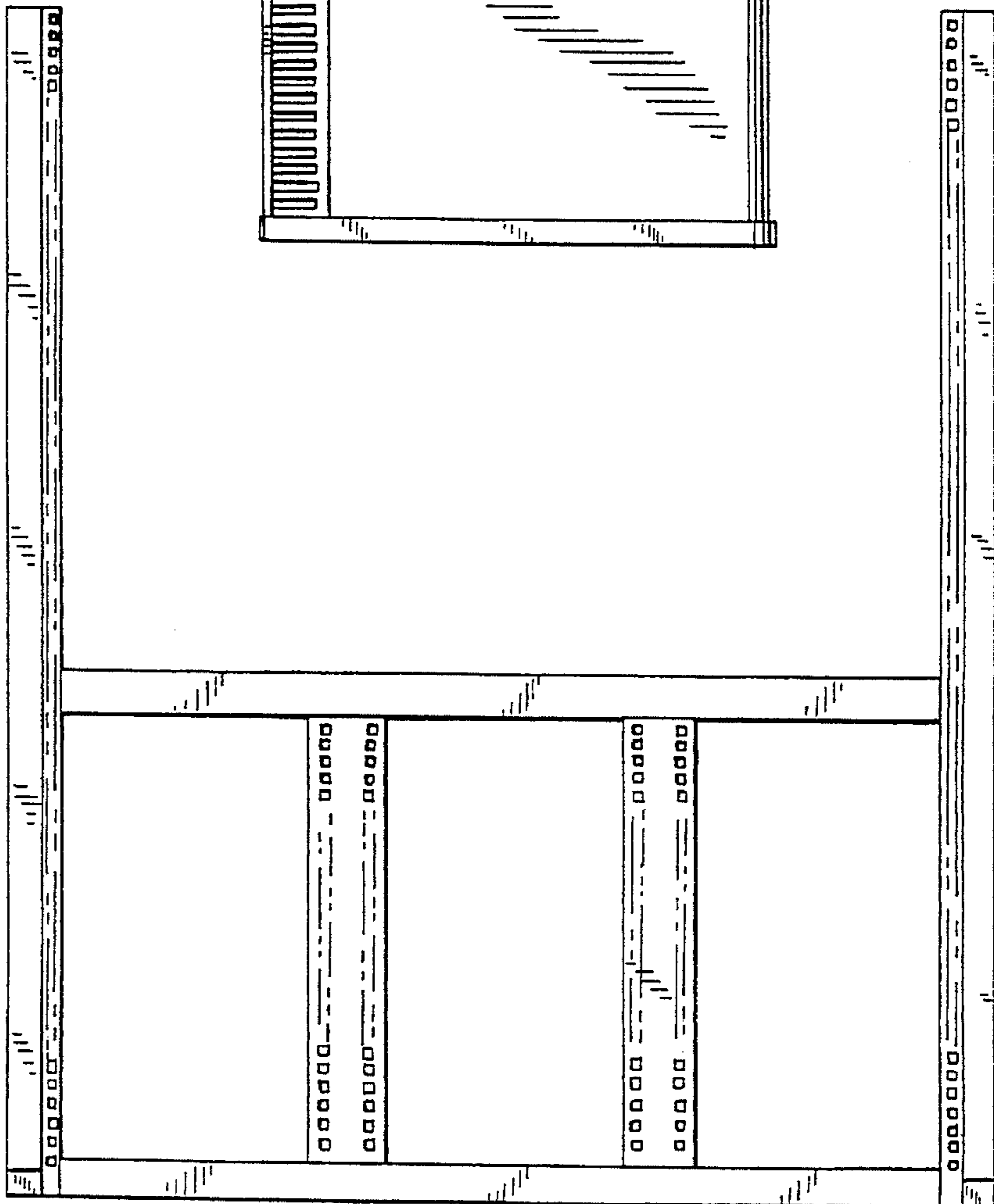

FIG. 15

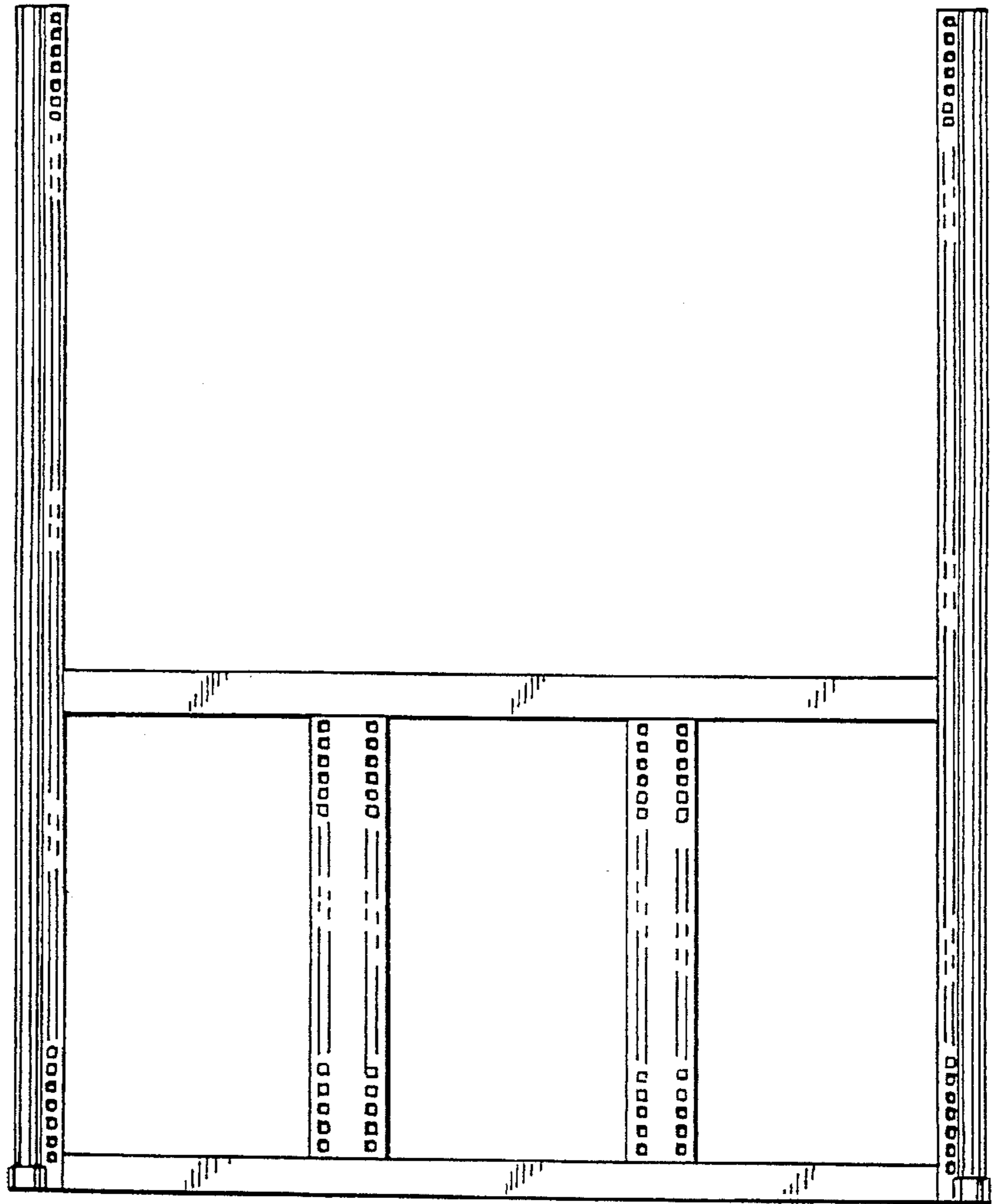

FIG. 14

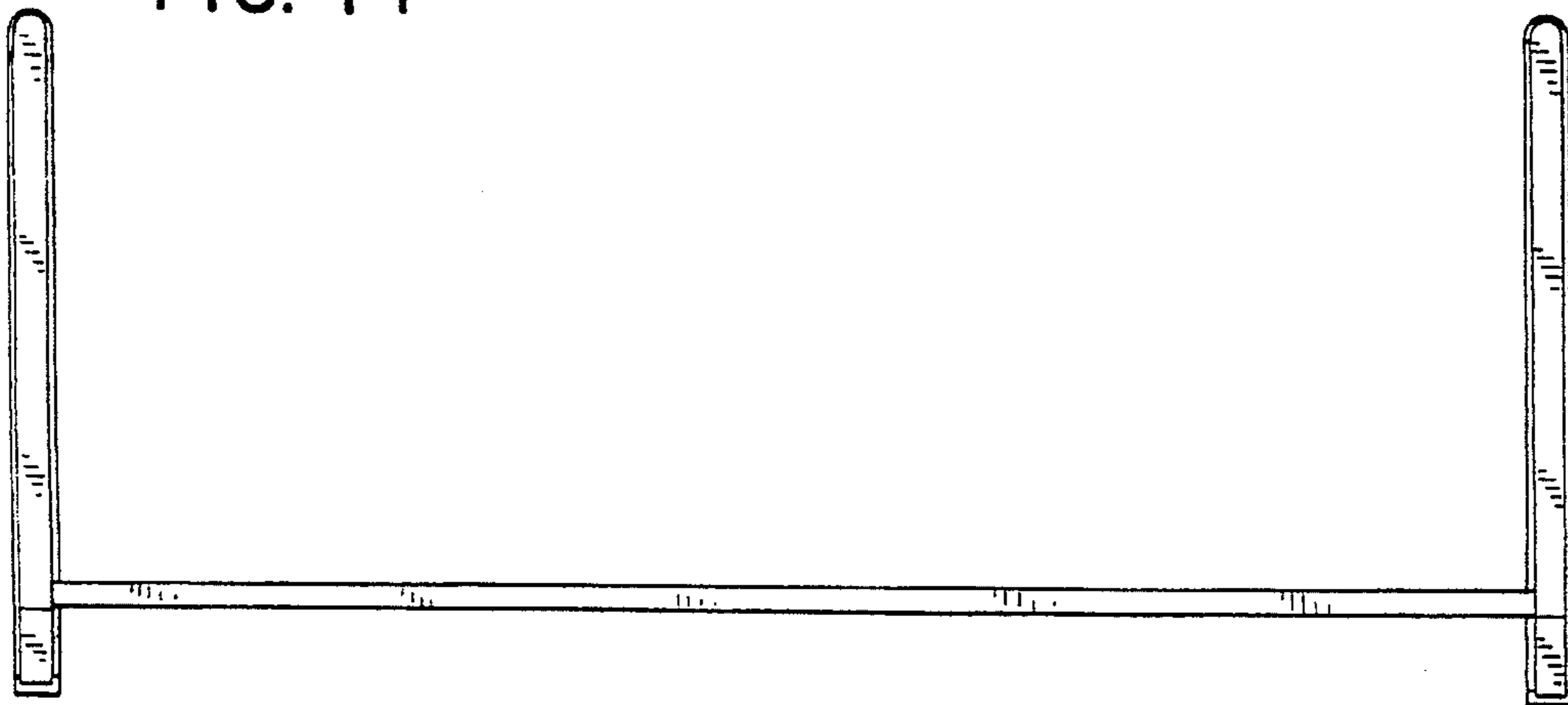

FIG. 16

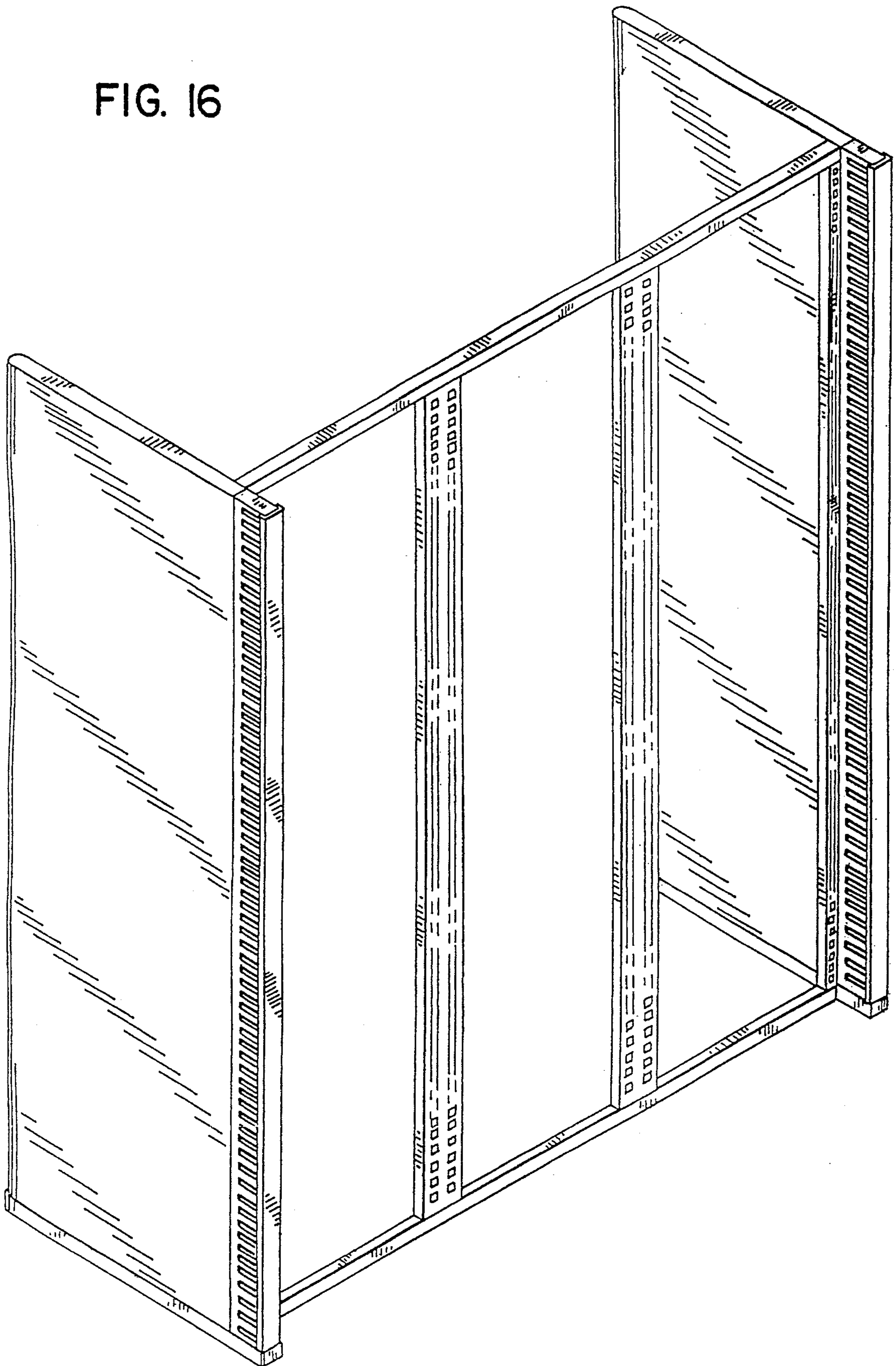

FIG. 17

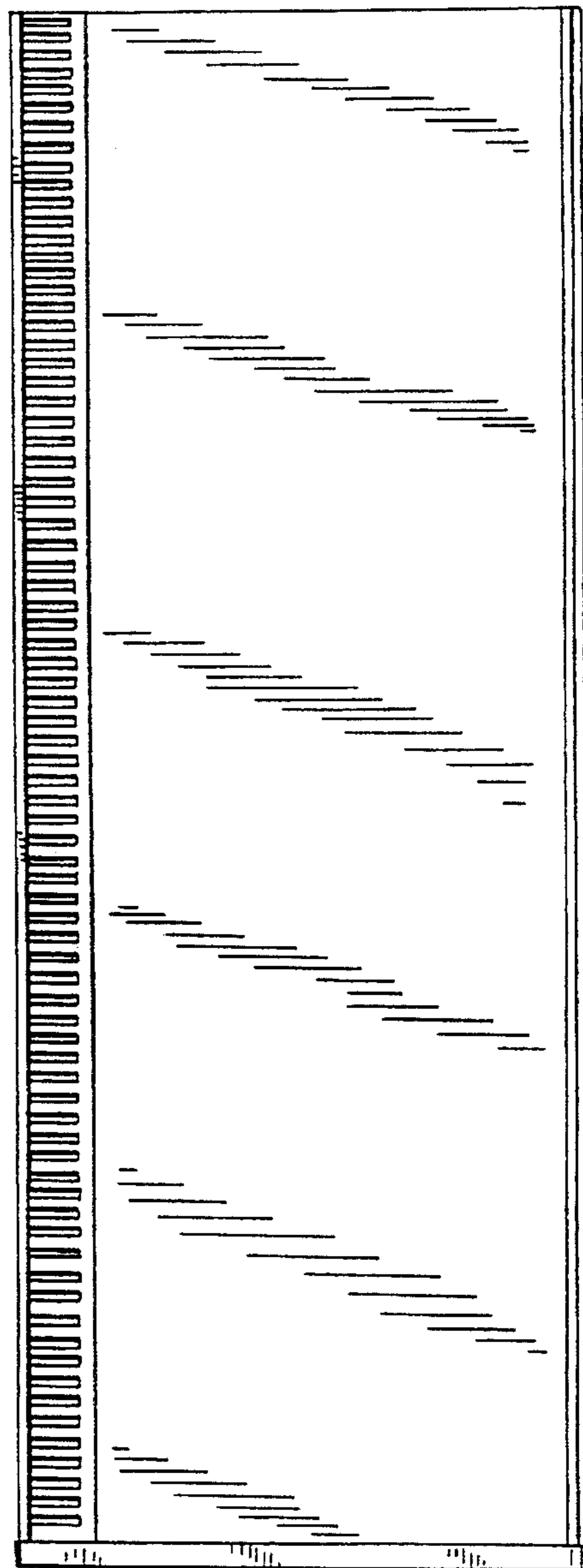

FIG. 18

