



US00D363698S

United States Patent [19] Smith

[11] Patent Number: **Des. 363,698**

[45] Date of Patent: ****Oct. 31, 1995**

[54] SEAT CADDY

4-92.

[75] Inventor: **Daniel G. Smith**, Grand Prairie, Tex.

[73] Assignee: **Texas Saddlebags Inc.**, Arlington, Tex.

[**] Term: **14 Years**

Primary Examiner—A. Hugo Word
Assistant Examiner—M. Brown
Attorney, Agent, or Firm—Daniel Rubin

[21] Appl. No.: **25,647**

[57] **CLAIM**

[22] Filed: **Jul. 7, 1994**

The ornamental design for a seat caddy, as shown and described.

[52] U.S. Cl. **D12/419**

[58] Field of Search D12/419, 416,
D12/420, 421, 424, 423; 224/273, 275,
24.11, 42.42; 296/37.13-37.16; 248/311.1

DESCRIPTION

[56] **References Cited**

U.S. PATENT DOCUMENTS

D. 199,993	1/1965	Cohen	D12/420
D. 252,540	8/1979	Murphy	D12/419
D. 267,444	1/1983	Ruxton	D12/419
D. 271,442	11/1983	Lehner	D12/419
D. 281,545	12/1985	Flanagan	D12/419
D. 317,674	6/1991	Smith	D12/419
D. 323,313	1/1992	Si	D12/419
D. 346,066	4/1994	Smith	D12/416
D. 352,495	11/1994	Mawhinney et al.	D12/419
4,796,791	1/1989	Goss et al.	224/42.42 X

FIG. 1 is a top perspective view of a seat caddy showing my new design, it being understood that the broken lines are shown for illustrative purposes only and form no part of the claimed design;

FIG. 2 is a right side elevation view thereof, the left side being a mirror image thereof;

FIG. 3 is a front elevational view thereof;

FIG. 4 is a rear elevational view thereof;

FIG. 5 is a top plan view thereof;

FIG. 6 is a bottom plan view thereof; and,

FIG. 7 is a top plan view thereof with the lid in raised condition, illustrating the interior surfaces.

OTHER PUBLICATIONS

J. C. Whitney & Co. Catalog, © 1992, No. 540J, p. 91, the storage console for pickups, suburbans & cars.
"Consoles for Pickups, Minivans & Cars" Saddlebags-Rex.

1 Claim, 3 Drawing Sheets

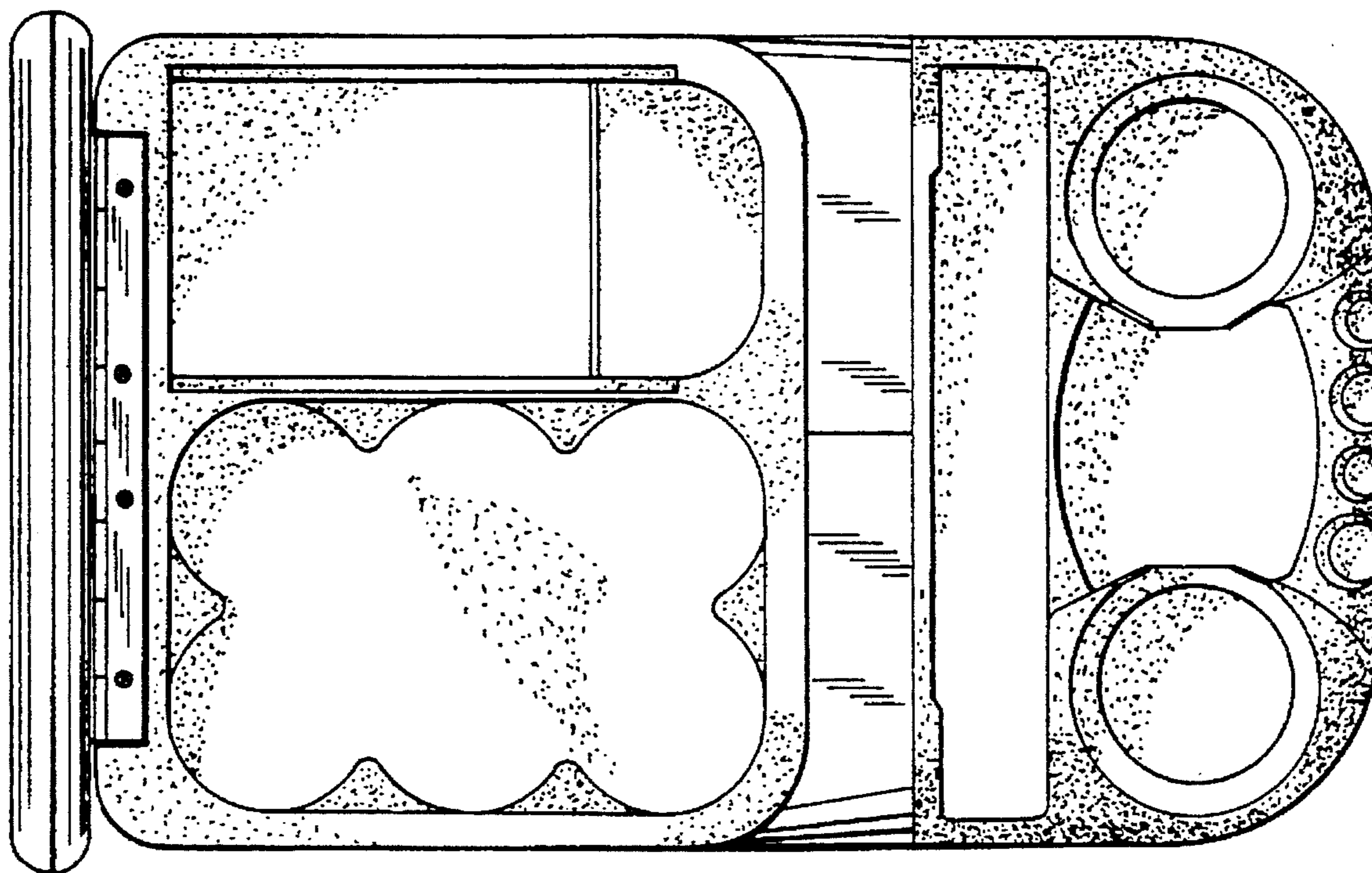

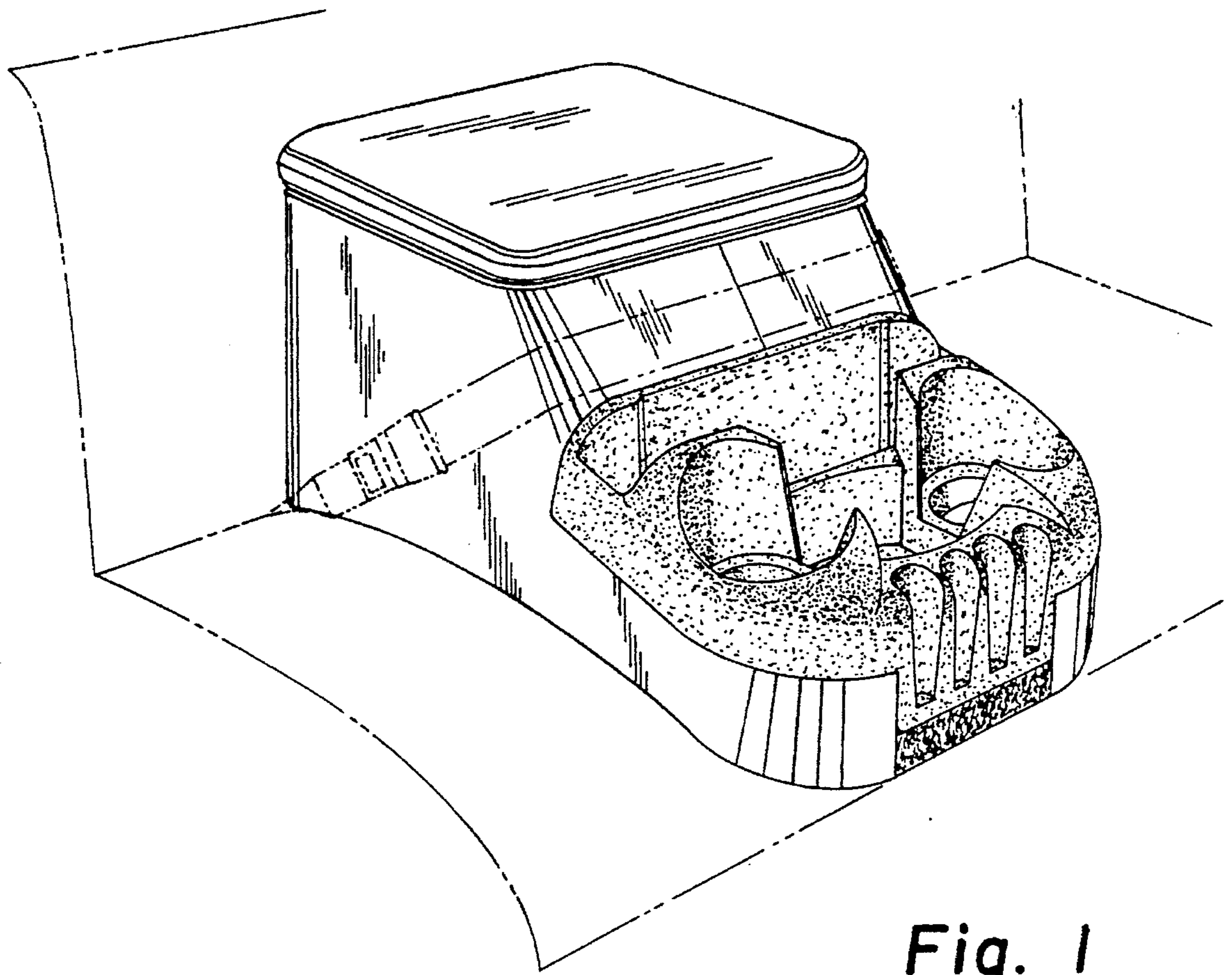

Fig. 1

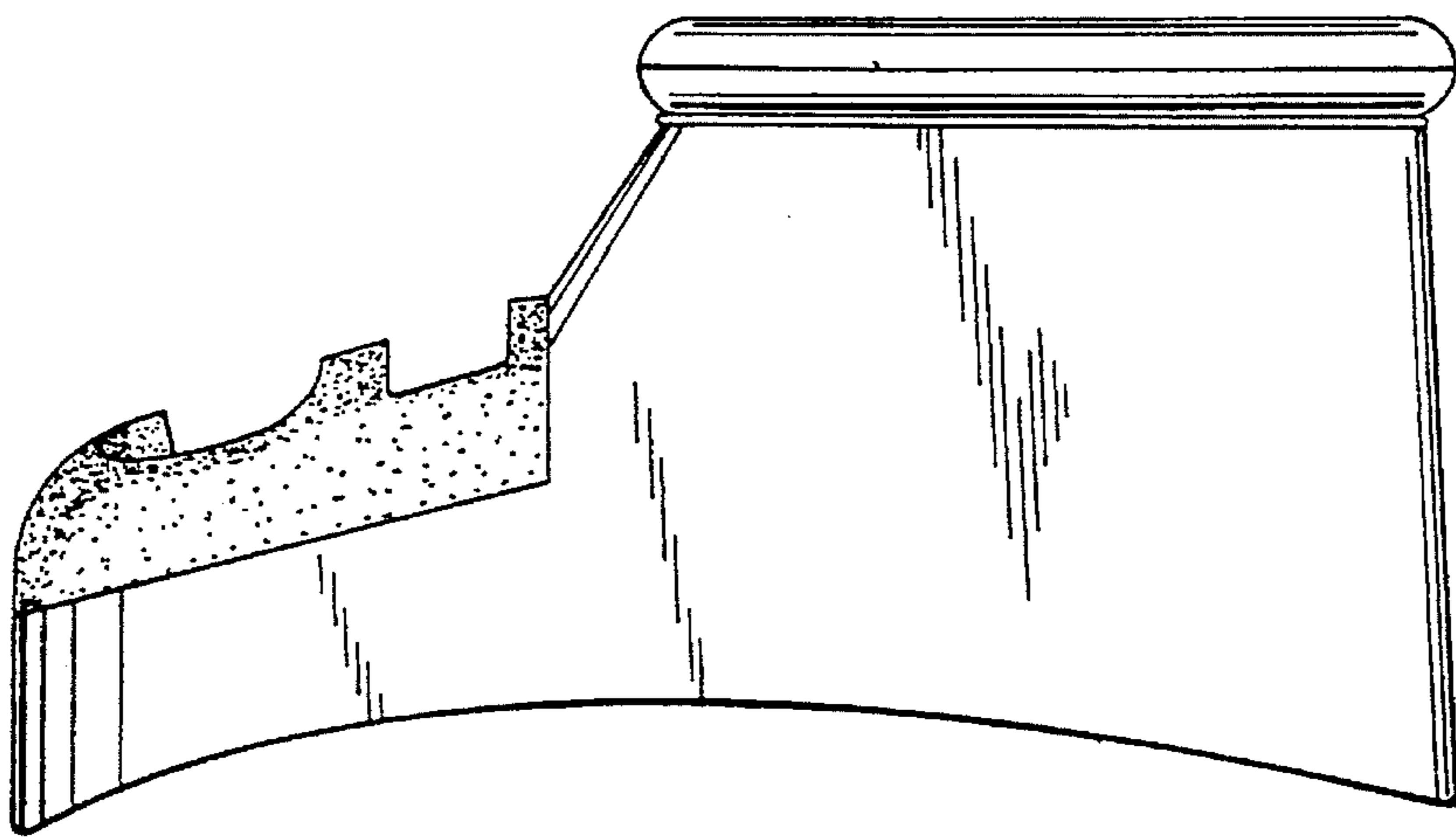

Fig. 2

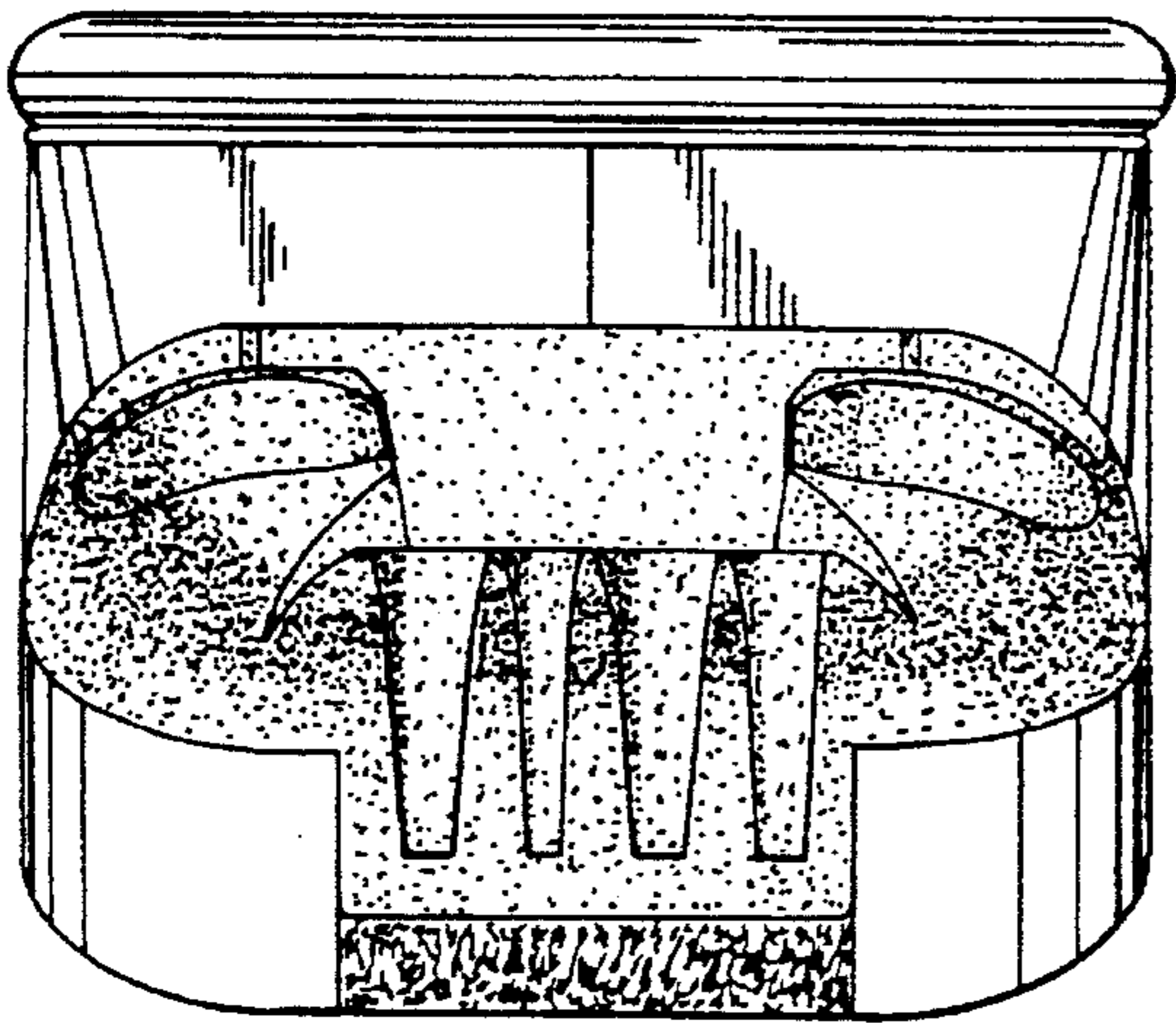

Fig. 3

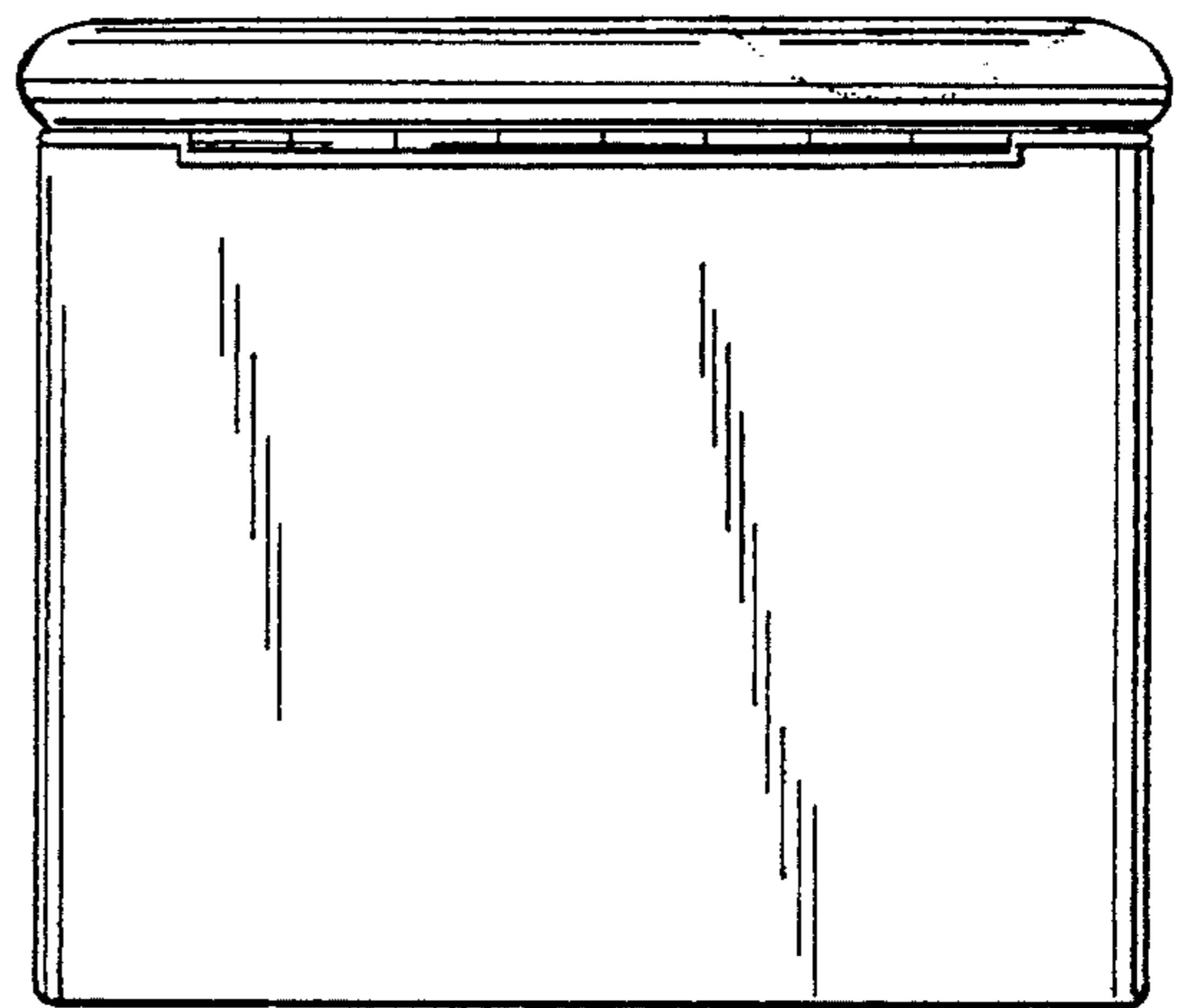

Fig. 4

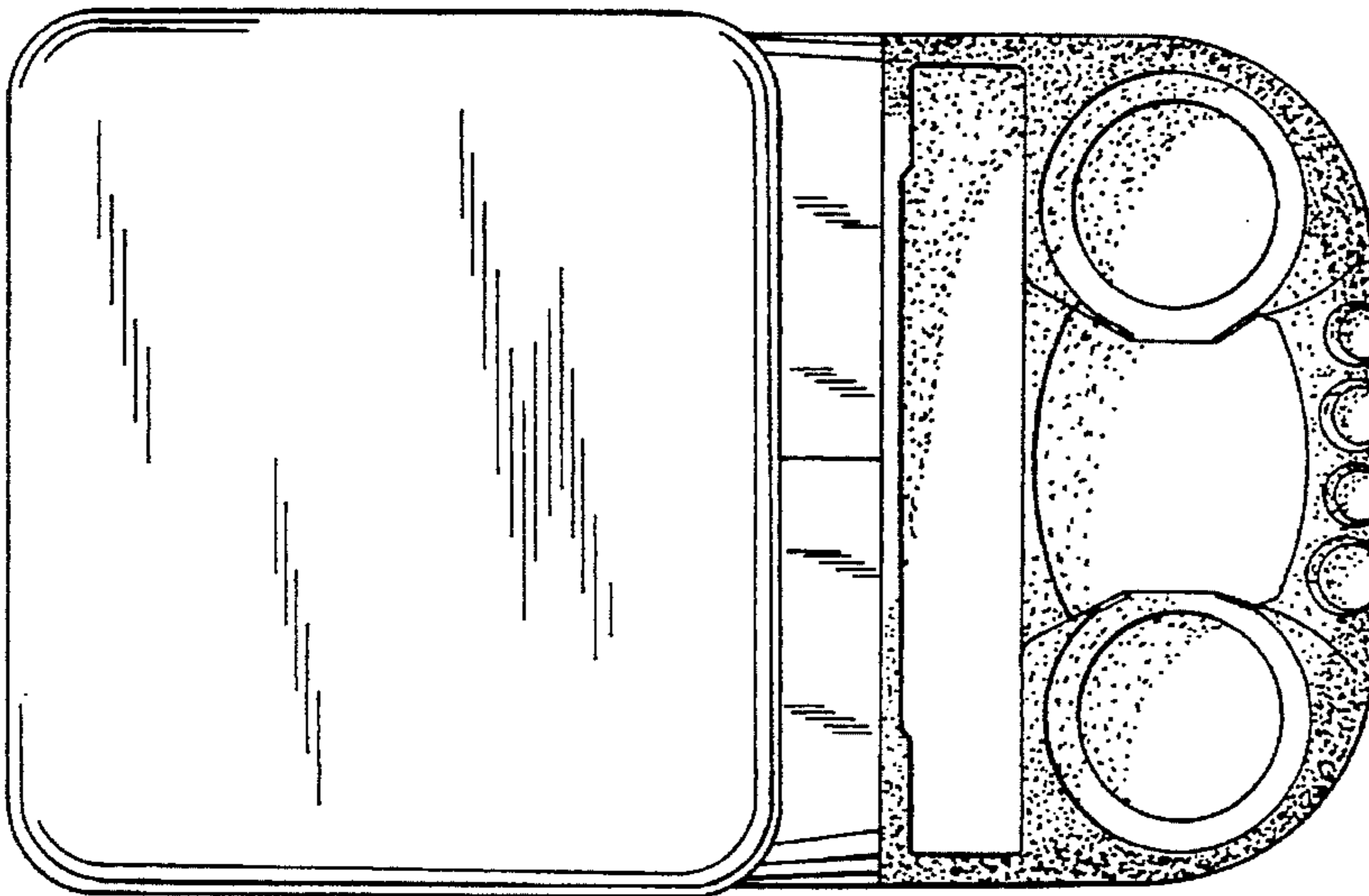

Fig. 5

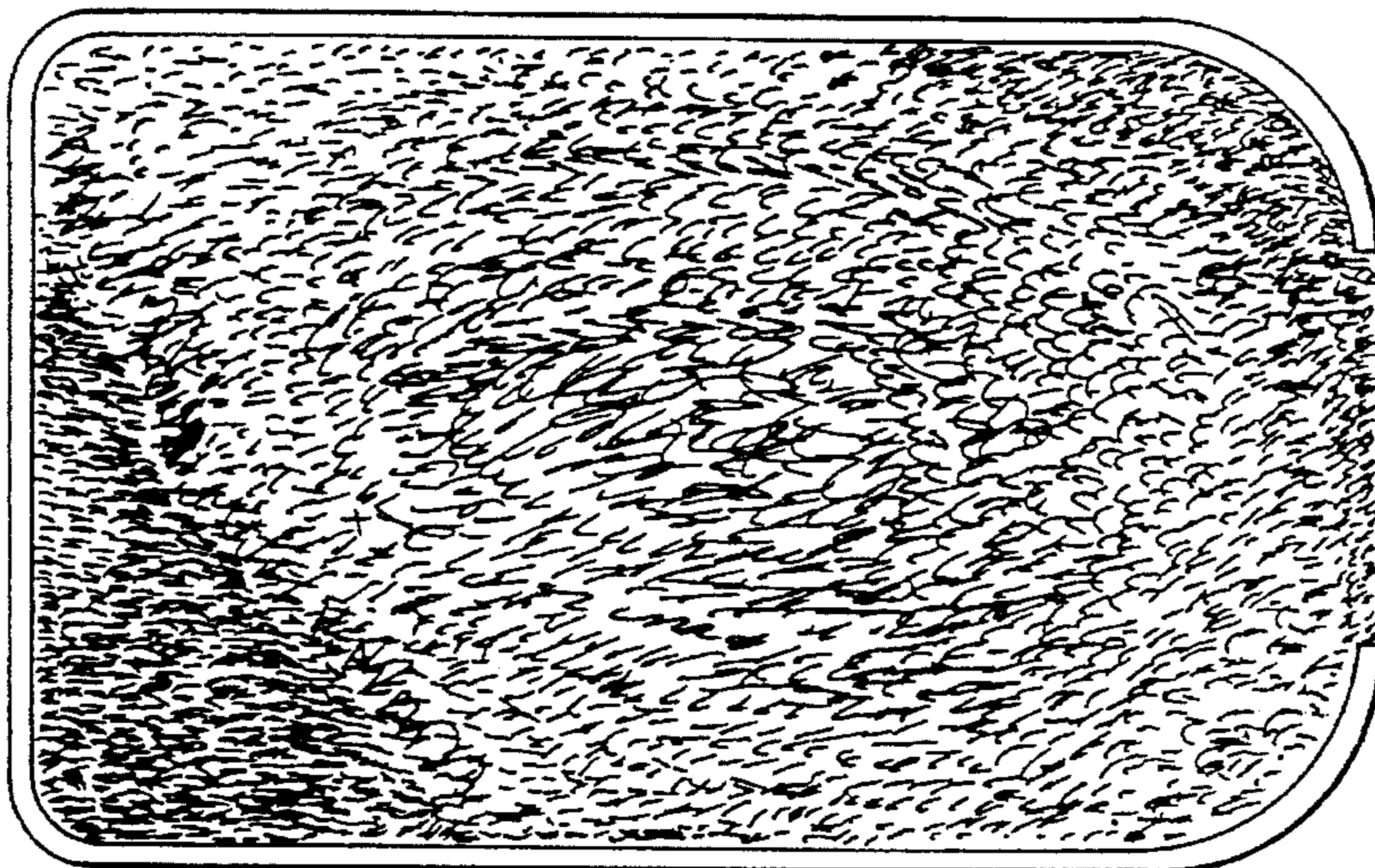

Fig. 6

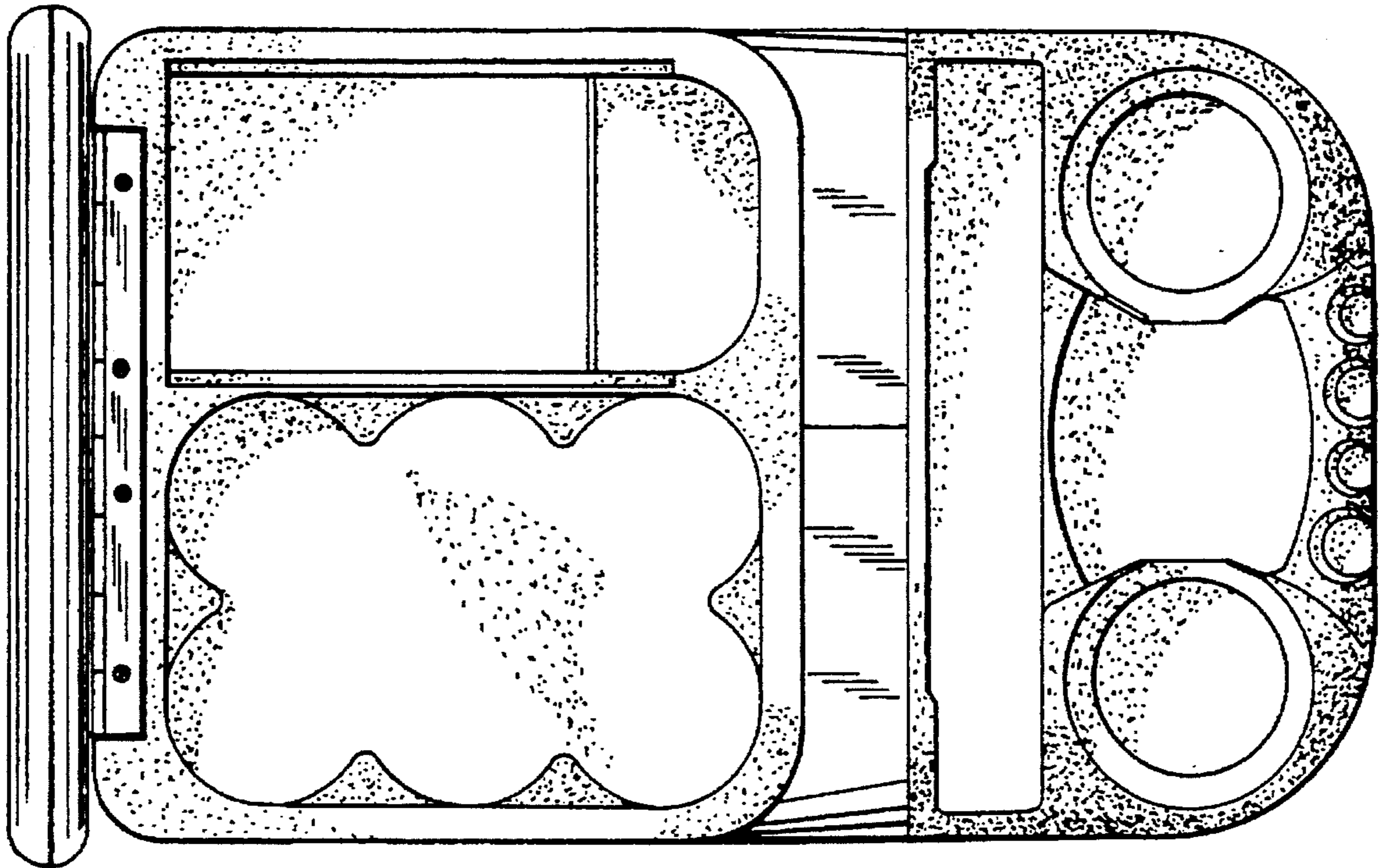

Fig. 7