



US00D363623S

United States Patent [19] Rushing

[11] Patent Number: **Des. 363,623**

[45] Date of Patent: ****Oct. 31, 1995**

[54] **DISPLAY STAND**

[75] Inventor: **Tom Rushing**, Denville, N.J.

[73] Assignee: **HMG Worldwide In-Store Marketing, Inc.**, New York, N.Y.

[**] Term: **14 Years**

[21] Appl. No.: **7,751**

[22] Filed: **Apr. 29, 1993**

[52] U.S. Cl. **D6/479**

[58] Field of Search D6/449, 450, 474,
D6/475, 476, 478, 463, 464, 462, 396;
211/126, 133, 134, 186, 10, 11, 13

[56] **References Cited**

U.S. PATENT DOCUMENTS

- D. 331,160 11/1992 Brunner D6/462 X
- D. 334,495 4/1993 Bustos D6/463 X
- D. 336,183 6/1993 Klein, III D6/449 X

- D. 336,803 6/1993 Stoddard et al. D6/476
- 4,762,235 8/1988 Howard et al. 211/126 X
- 4,974,734 12/1990 Merl 211/133 X

Primary Examiner—Alan P. Douglas
Assistant Examiner—S. Snapp
Attorney, Agent, or Firm—Cohen, Pontani, Lieberman, Pavane

[57] **CLAIM**

The ornamental design for a product display stand, as shown and described.

DESCRIPTION

FIG. 1 is a front perspective view of my design;
FIG. 2 is a top plan view thereof;
FIG. 3 is a front elevation view thereof;
FIG. 4 is a left side elevation view thereof;
FIG. 5 is a bottom plan view thereof; and,
FIG. 6 is a right side elevation view thereof.

1 Claim, 6 Drawing Sheets

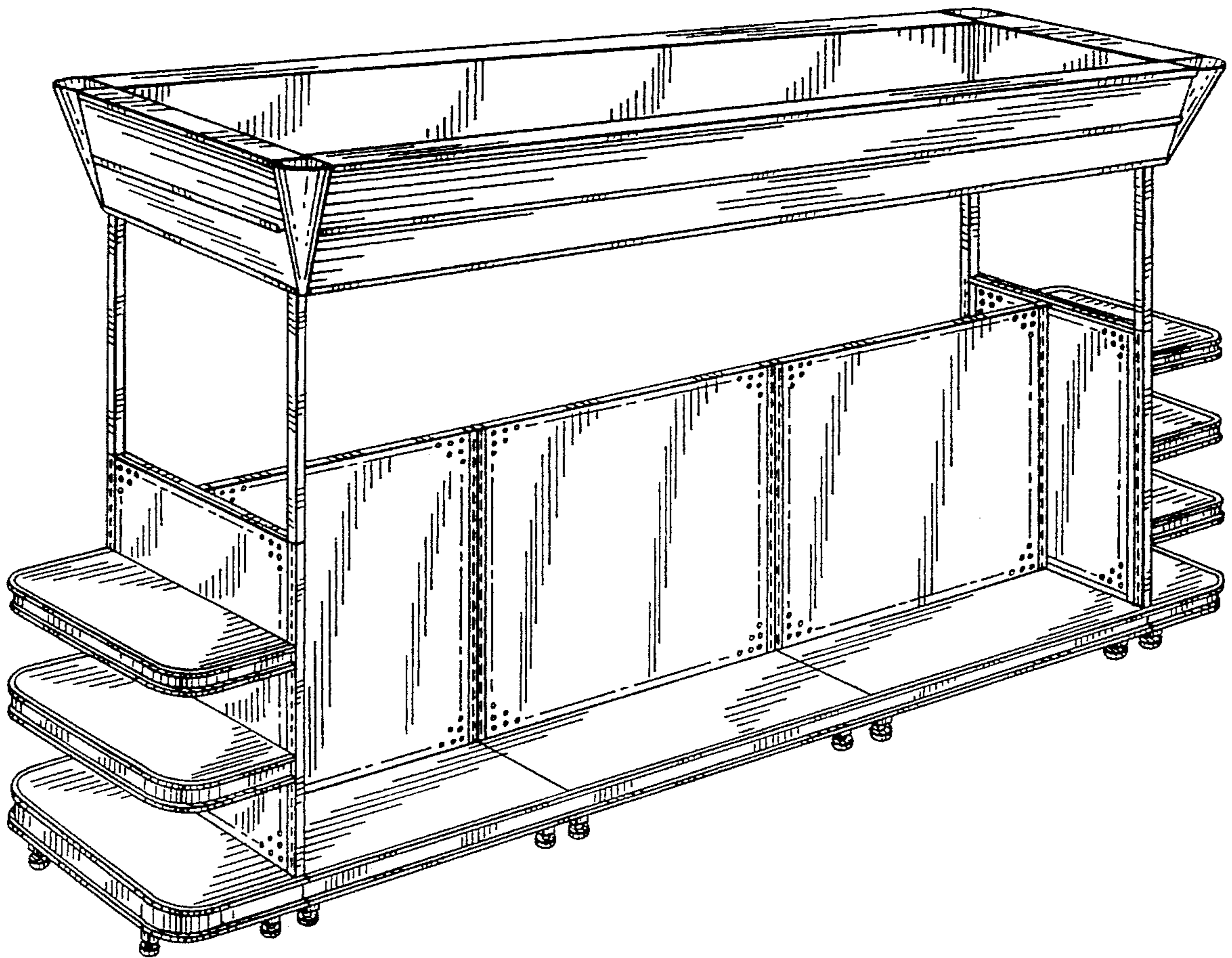

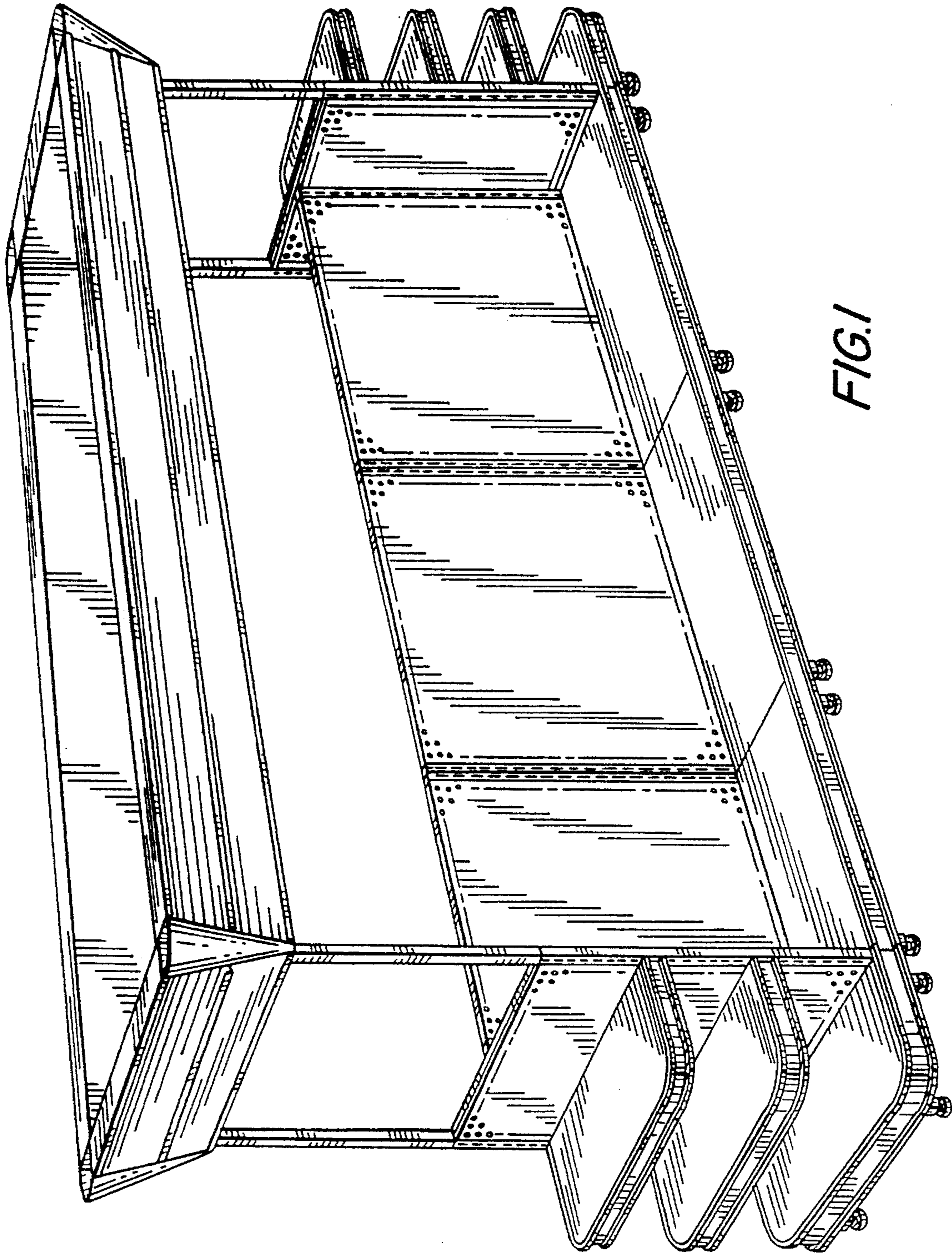

FIG. 1

FIG. 2

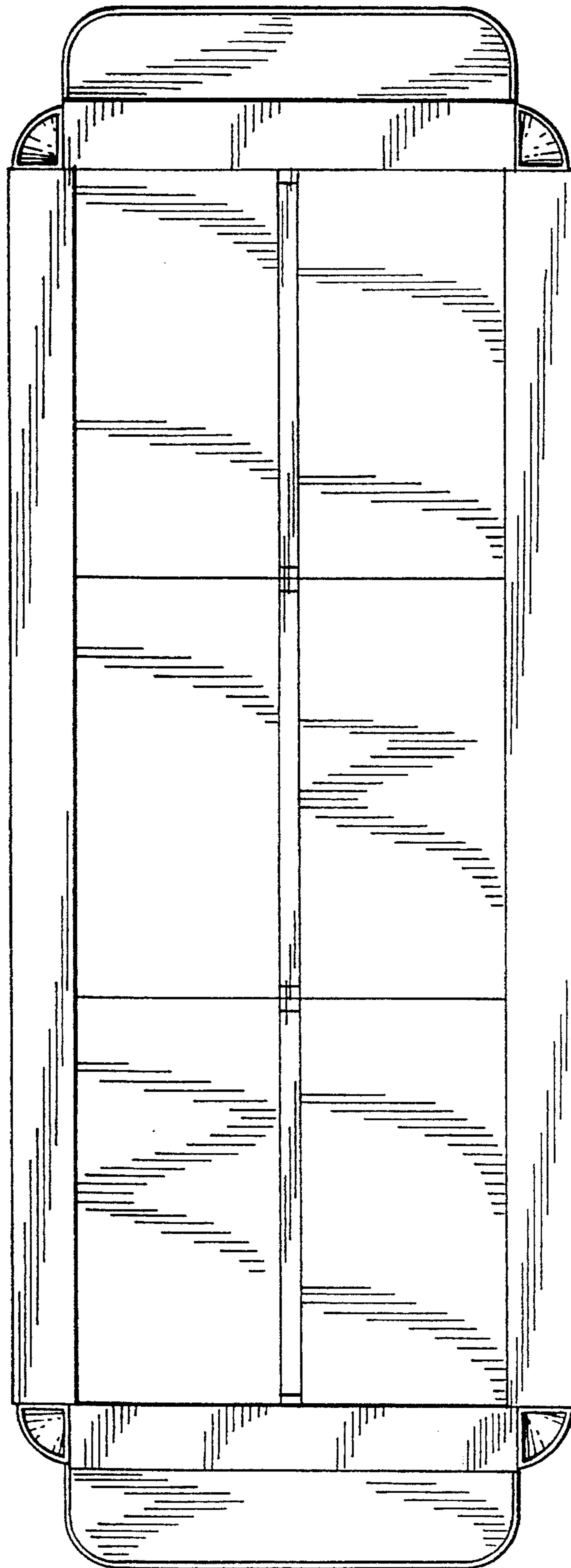
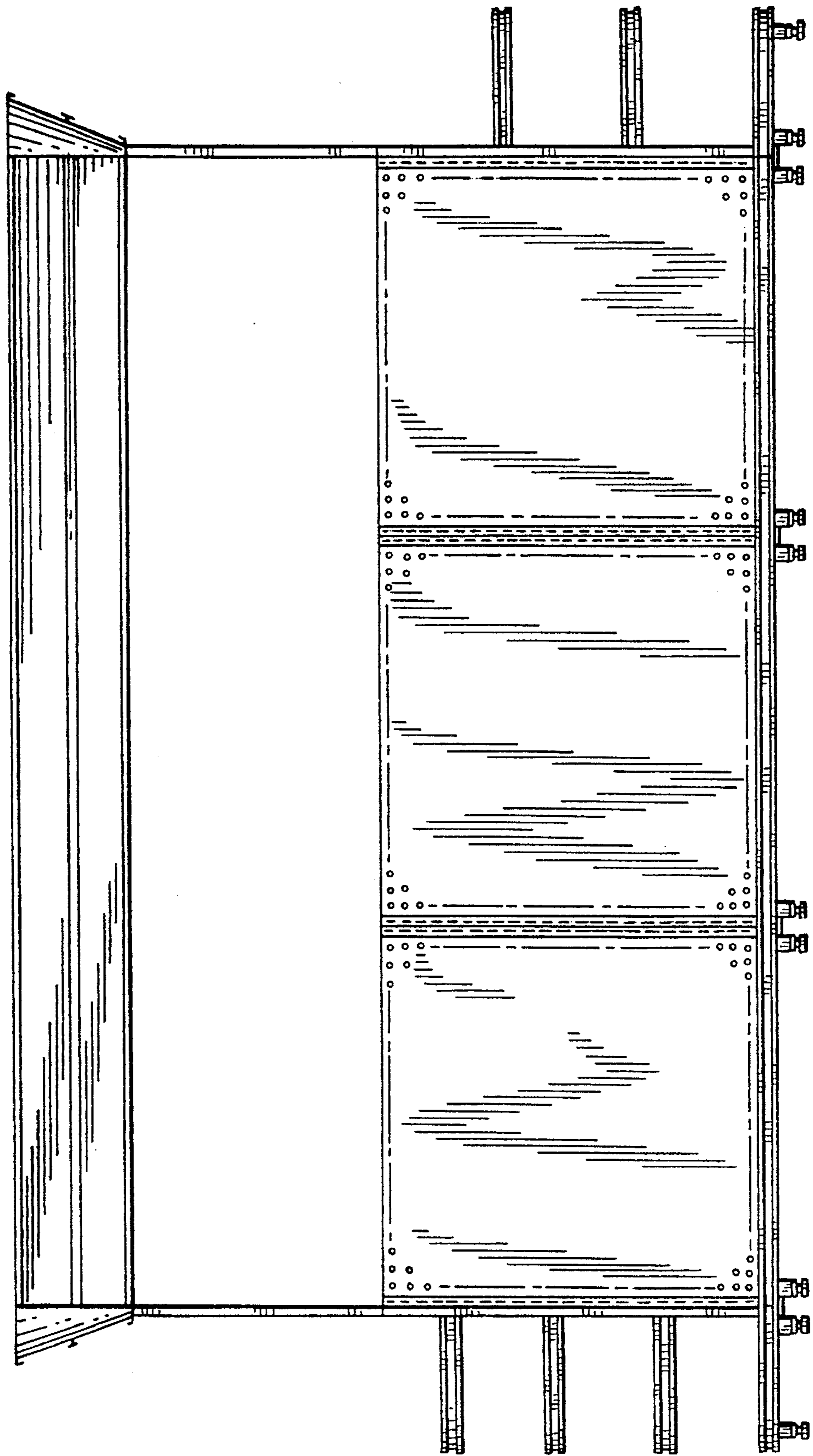

FIG. 3



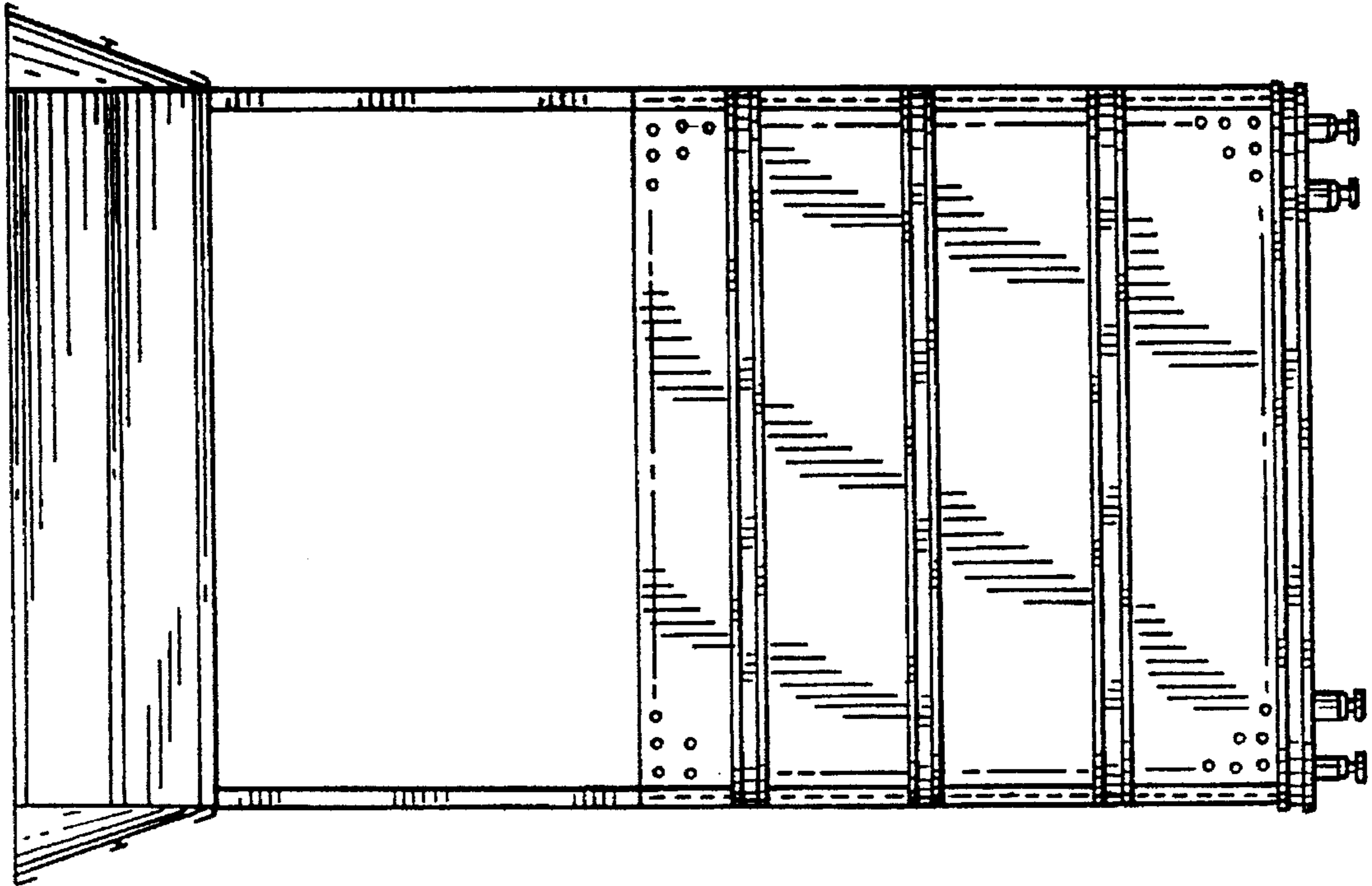
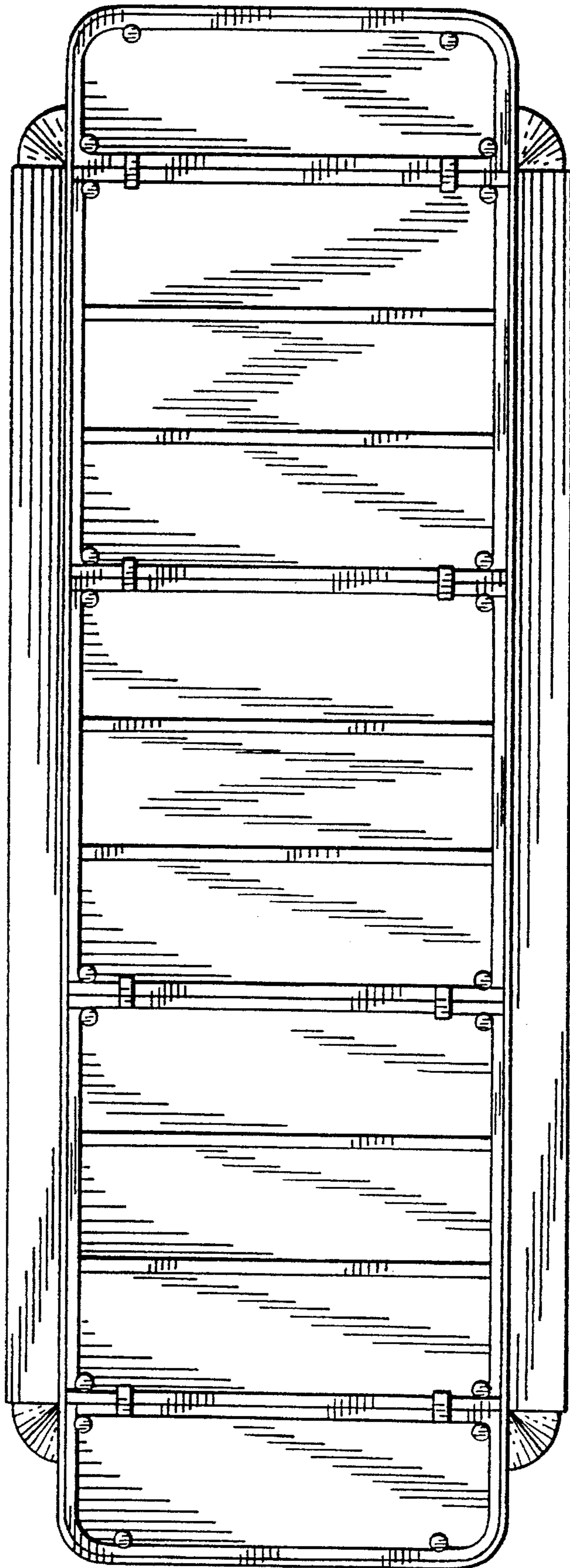

FIG. 4

FIG. 5



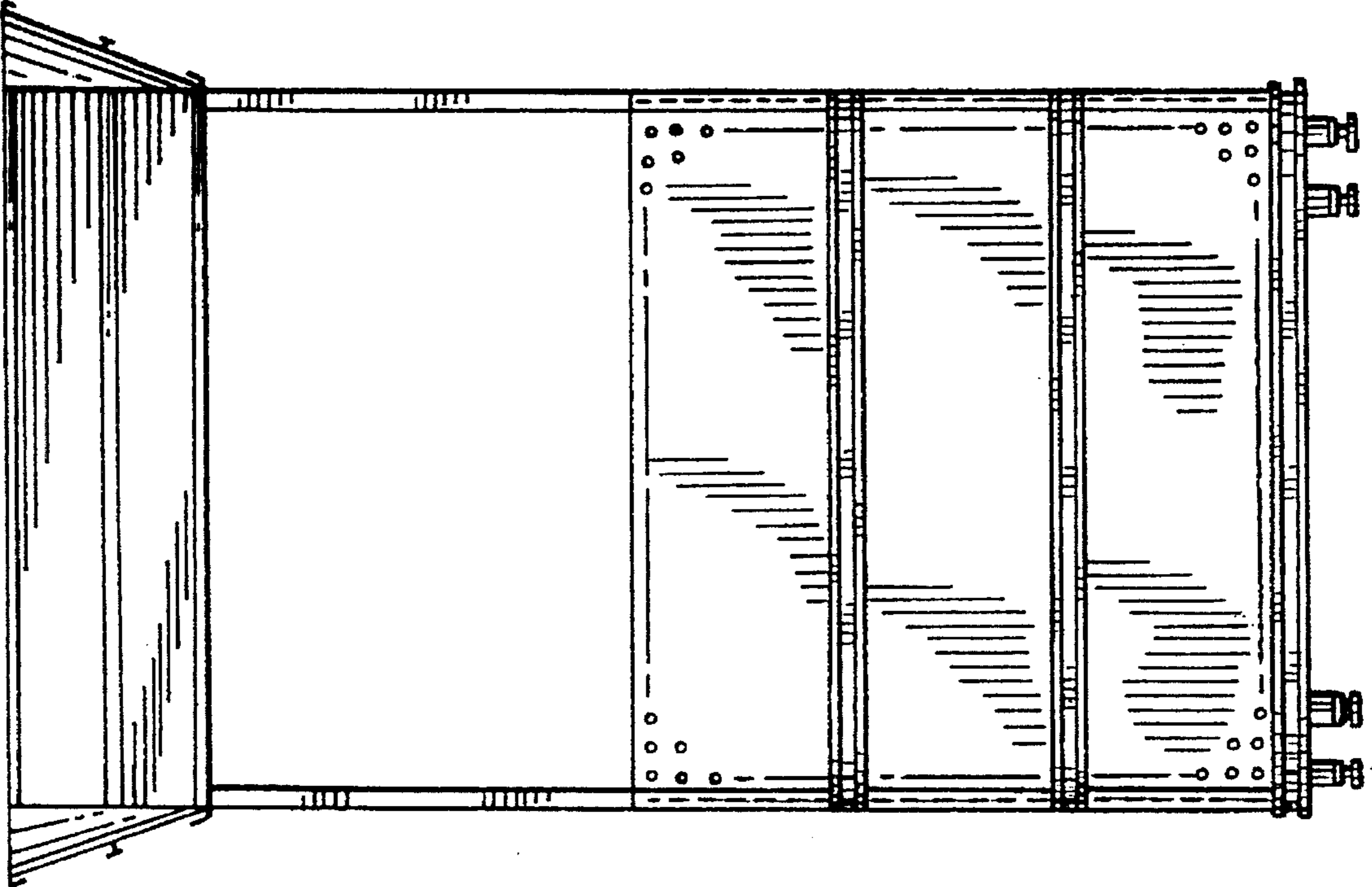

FIG. 6