



US00D363460S

**United States Patent** [19]  
**Marshall**

[11] **Patent Number: Des. 363,460**  
[45] **Date of Patent: \*\*Oct. 24, 1995**

[54] **TRUCK RACK**

[76] Inventor: **Albert L. Marshall**, 17 Bermuda Dr.,  
Jackson, Tenn. 38305

[\*\*] Term: **14 Years**

[21] Appl. No.: **23,988**

[22] Filed: **Jun. 6, 1994**

[52] U.S. Cl. .... **D12/406; D12/48**

[58] **Field of Search** ..... D12/406, 414,  
D12/412, 98, 96; D25/38, 53, 58, 152-155;  
296/3, 43, 10, 26; 227/42.25 R, 42.42,  
321, 325, 309, 282

[56] **References Cited**

**U.S. PATENT DOCUMENTS**

D. 40,291	10/1909	Burgess et al. ....	D25/155
D. 85,600	11/1931	Russell .....	D25/154
D. 153,085	3/1949	Powers .....	D12/96
D. 242,440	11/1976	Goldberger .....	D12/98
D. 269,380	6/1983	d'Avila .....	D25/53
D. 272,817	2/1984	Mareyilt .....	D12/414
D. 295,619	5/1988	Reeve .....	D12/414
D. 297,055	8/1988	McElvanna .....	D25/38
D. 301,134	5/1989	Ellison .....	D12/414
D. 338,072	8/1993	Nozicka .....	D25/38
D. 341,430	11/1993	Cardona .....	D25/48
2,751,248	6/1956	Kritser .....	296/43
3,460,864	8/1969	Piercy .....	296/3
3,475,046	10/1969	Webster .....	296/3
3,736,720	6/1973	Larson .....	52/741
4,231,606	11/1980	Tuerk .....	296/43
4,267,948	5/1981	Lewis .....	296/3

4,695,087	9/1987	Hollrock .....	296/14
4,703,969	11/1987	Rayburn et al. ....	296/3
4,770,458	9/1988	Burke et al. ....	224/24.25 R
5,108,141	4/1992	Anderson .....	296/3
5,143,415	9/1992	Boudah .....	224/325
5,316,190	5/1994	Bullock .....	224/42.42

**FOREIGN PATENT DOCUMENTS**

47022	9/1991	European Pat. Off. .
1003892	9/1965	United Kingdom .
1180058	9/1967	United Kingdom .

*Primary Examiner*—A. Hugo Word  
*Assistant Examiner*—Melody N. Brown  
*Attorney, Agent, or Firm*—Richard C. Litman

[57] **CLAIM**

The ornamental design for a truck rack, as shown and described.

**DESCRIPTION**

FIG. 1 is an environmental perspective view of a truck rack showing my new design;  
FIG. 2 is a bottom plan view thereof;  
FIG. 3 is a left side elevational view, with the right side being a mirror image thereof;  
FIG. 4 is a top plan view thereof;  
FIG. 5 is a front elevational view thereof; and,  
FIG. 6 is a rear elevational view thereof.  
The broken lines showing of the truck in FIG. 1 are for illustrative purposes only and form no part of the claimed design.

**1 Claim, 3 Drawing Sheets**

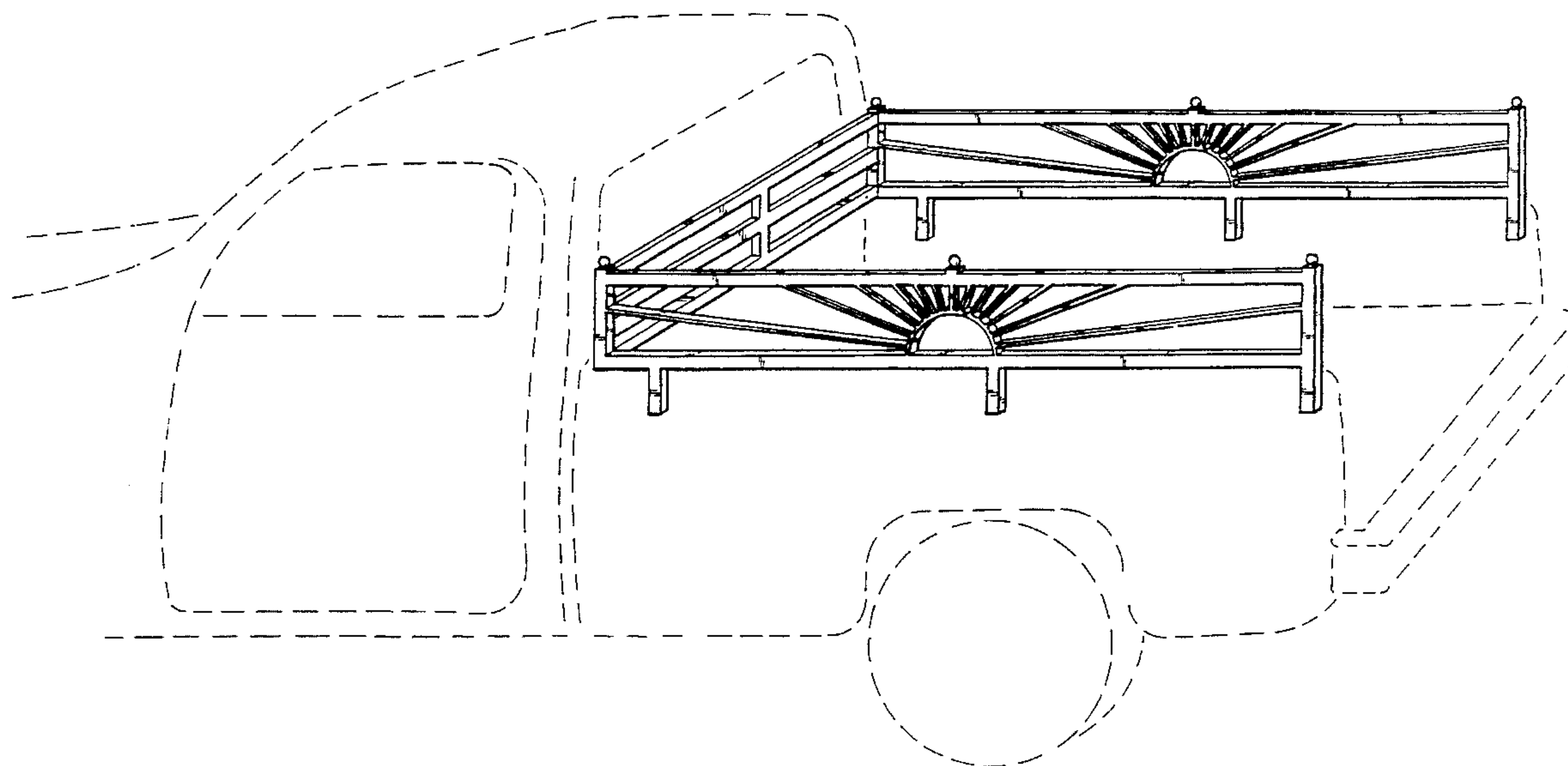

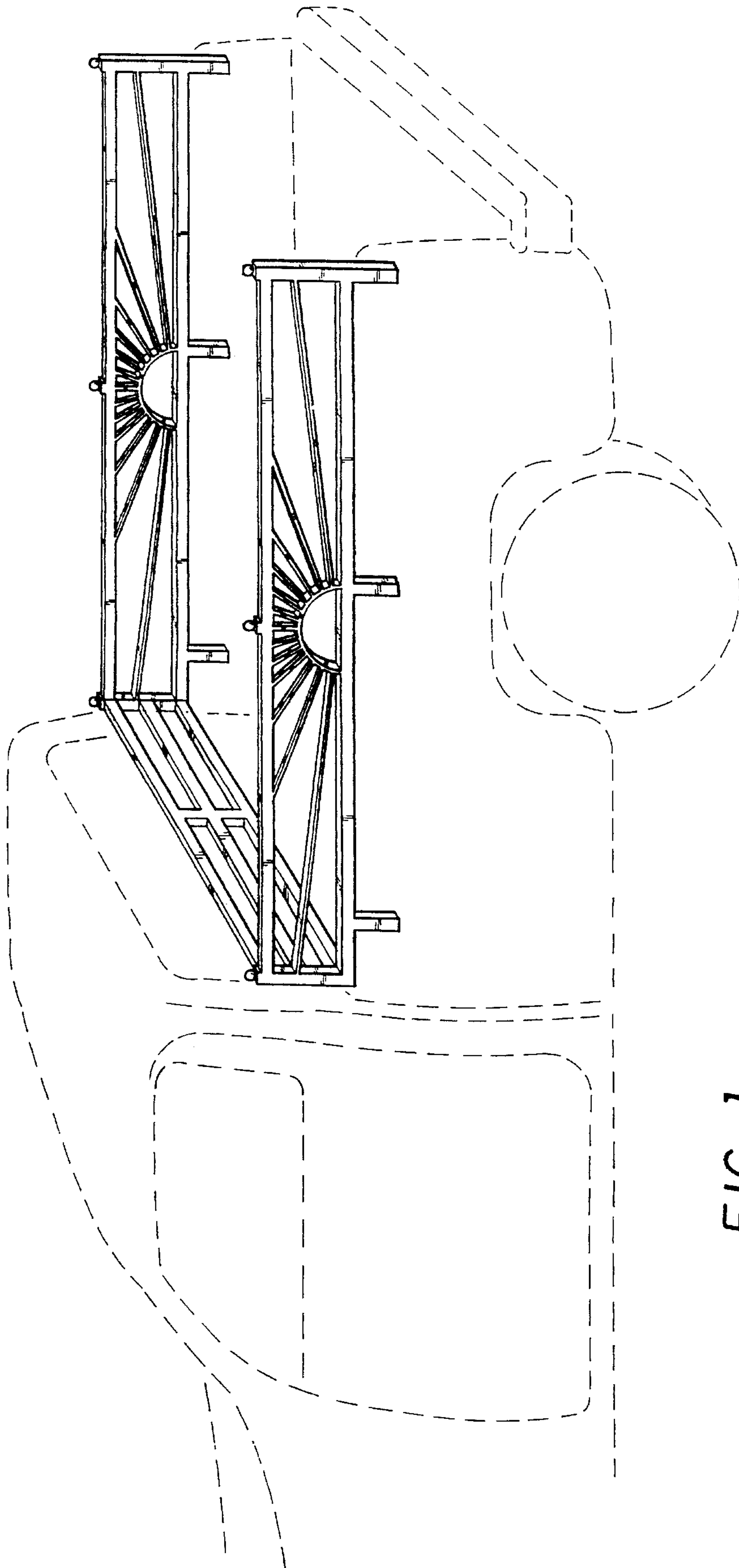

FIG. 1

FIG. 2

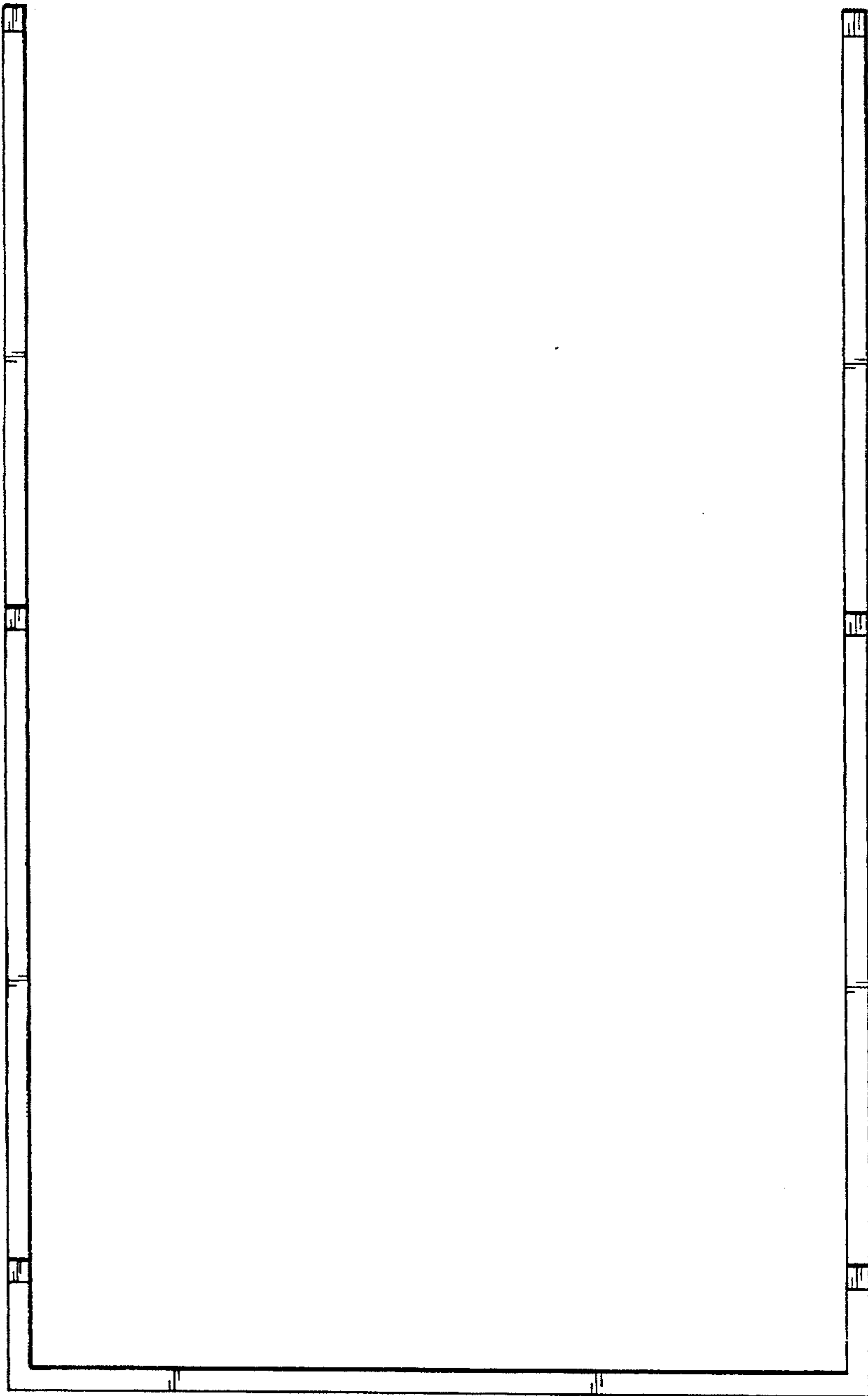
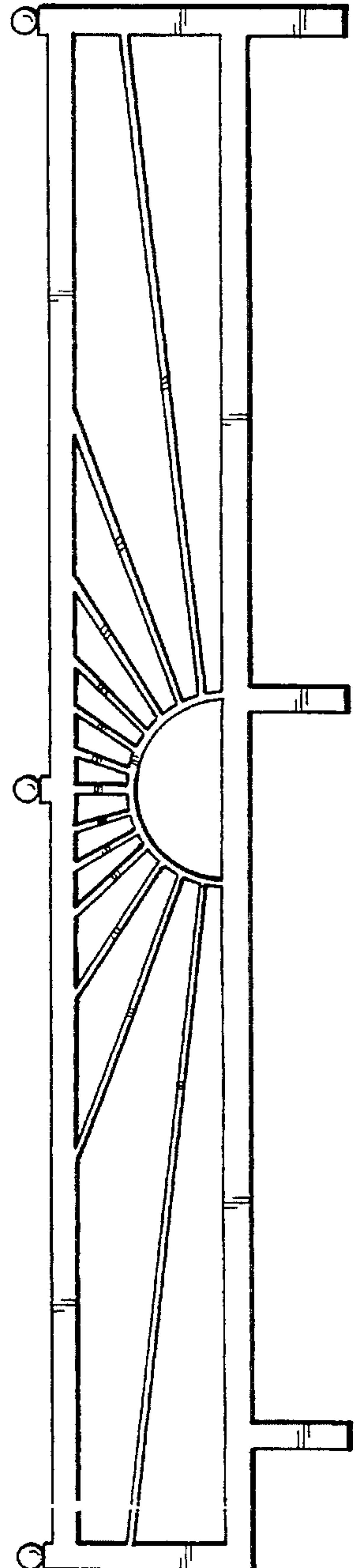

FIG. 3



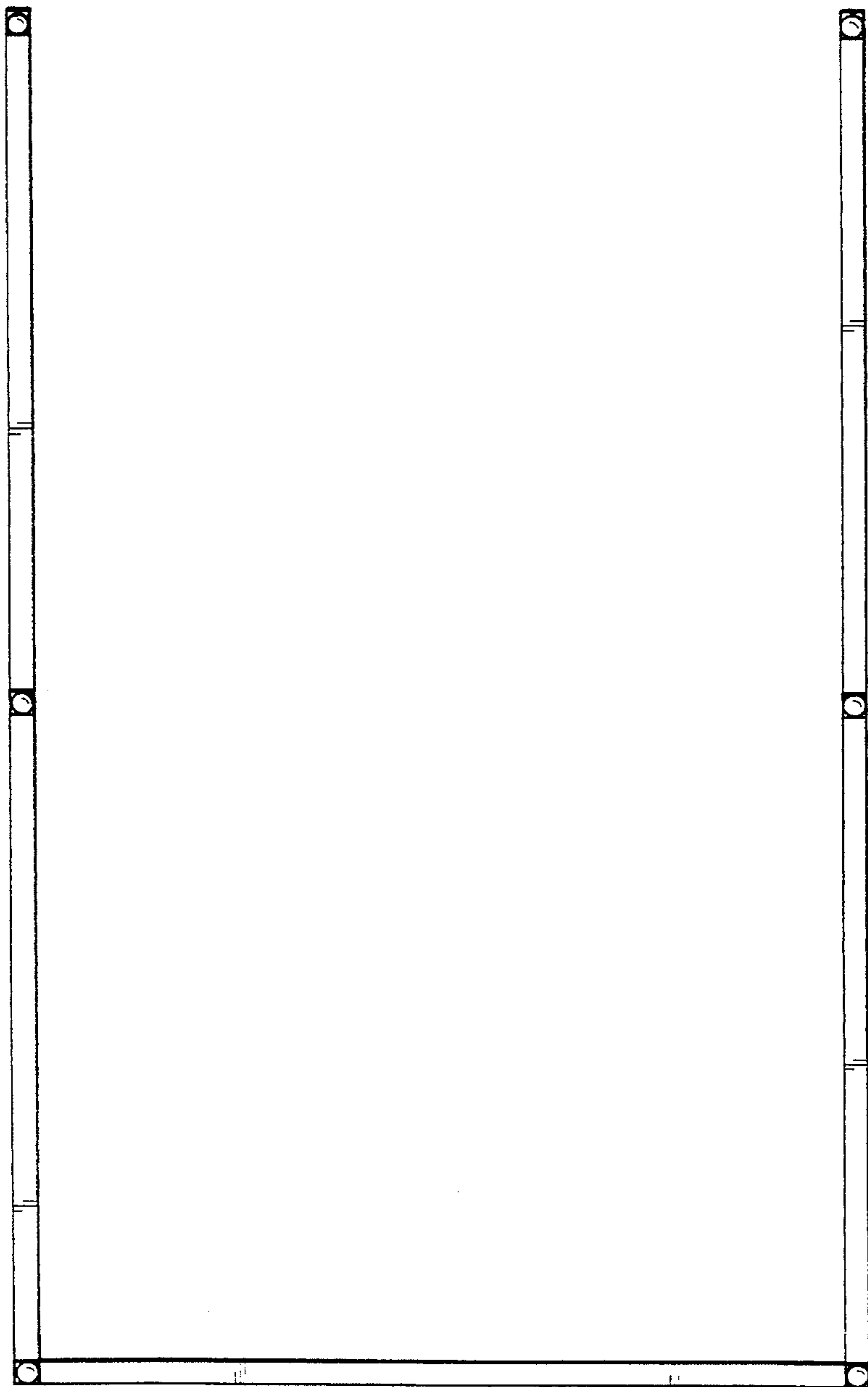

FIG. 4

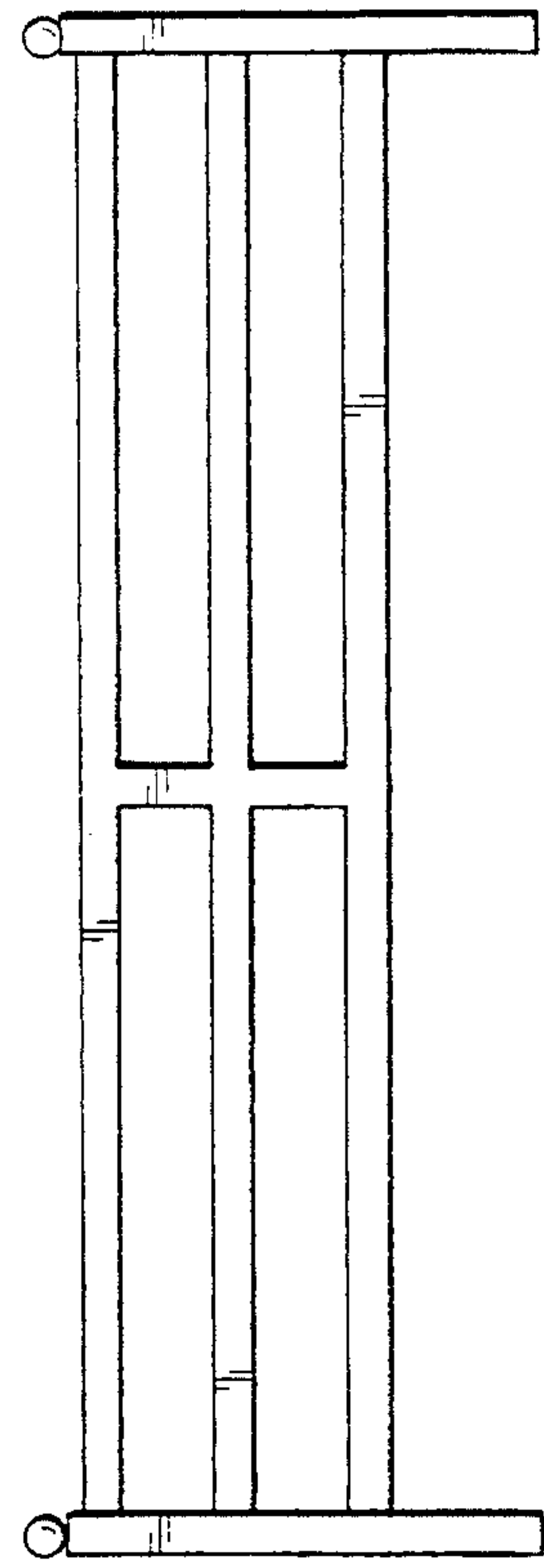

FIG. 6

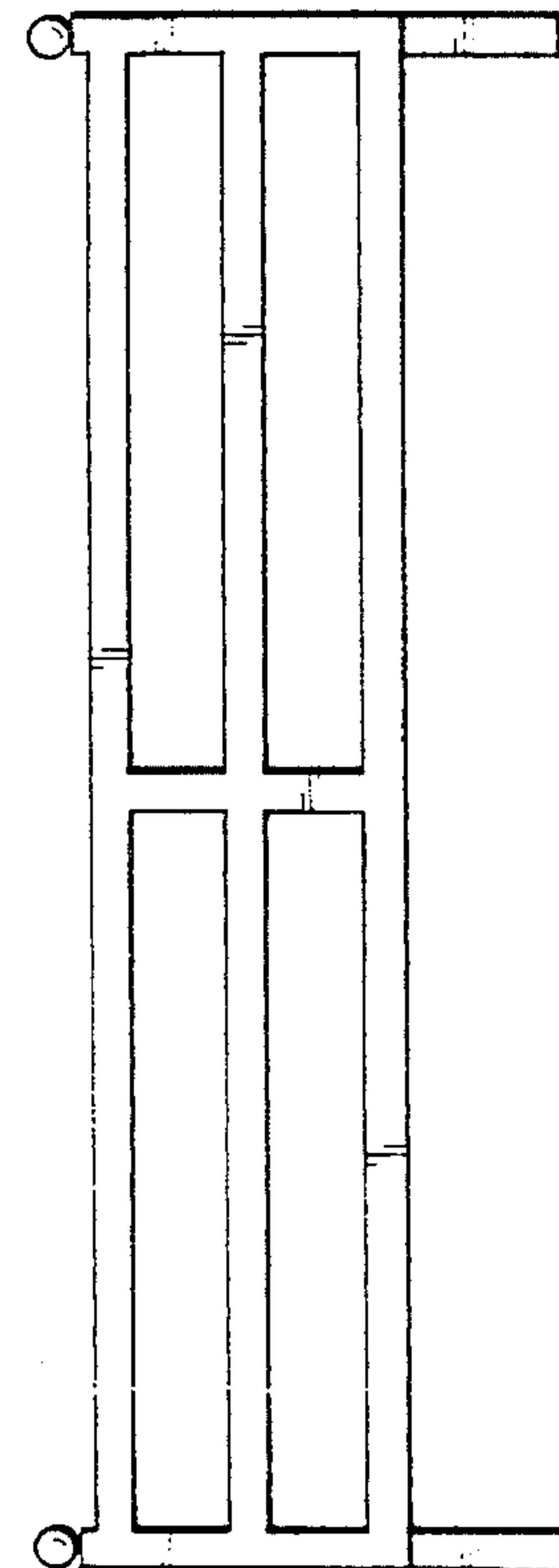

FIG. 5