



US00D363441S

**United States Patent** [19]  
**Chang**

[11] **Patent Number: Des. 363,441**  
[45] **Date of Patent: \*\*Oct. 24, 1995**

[54] **ELECTRICAL MULTIMETER**

[75] Inventor: **Shang-Wen Chang**, Taipei Hsien,  
Taiwan

[73] Assignee: **APPA Technology Corporation**, Taipei  
Hsien, Taiwan

[\*\*] Term: **14 Years**

[21] Appl. No.: **32,267**

[22] Filed: **Dec. 13, 1994**

[52] U.S. Cl. .... **D10/79**

[58] Field of Search ..... D10/79; 324/72.5,  
324/73 R, 127, 129, 133, 149, 156, 126,  
128, 130, 158 P, 158 F

[56] **References Cited**

**U.S. PATENT DOCUMENTS**

D. 203,181 12/1965 Koch ..... D10/79 X  
D. 271,948 12/1983 Kuramoto ..... D10/79

D. 274,892 7/1984 Fallon et al. .... D10/79  
D. 332,574 1/1993 Chang ..... D10/79 X  
D. 345,704 4/1994 Shirai ..... D10/79

*Primary Examiner*—Antoine Duval Davis  
*Attorney, Agent, or Firm*—Bacon & Thomas

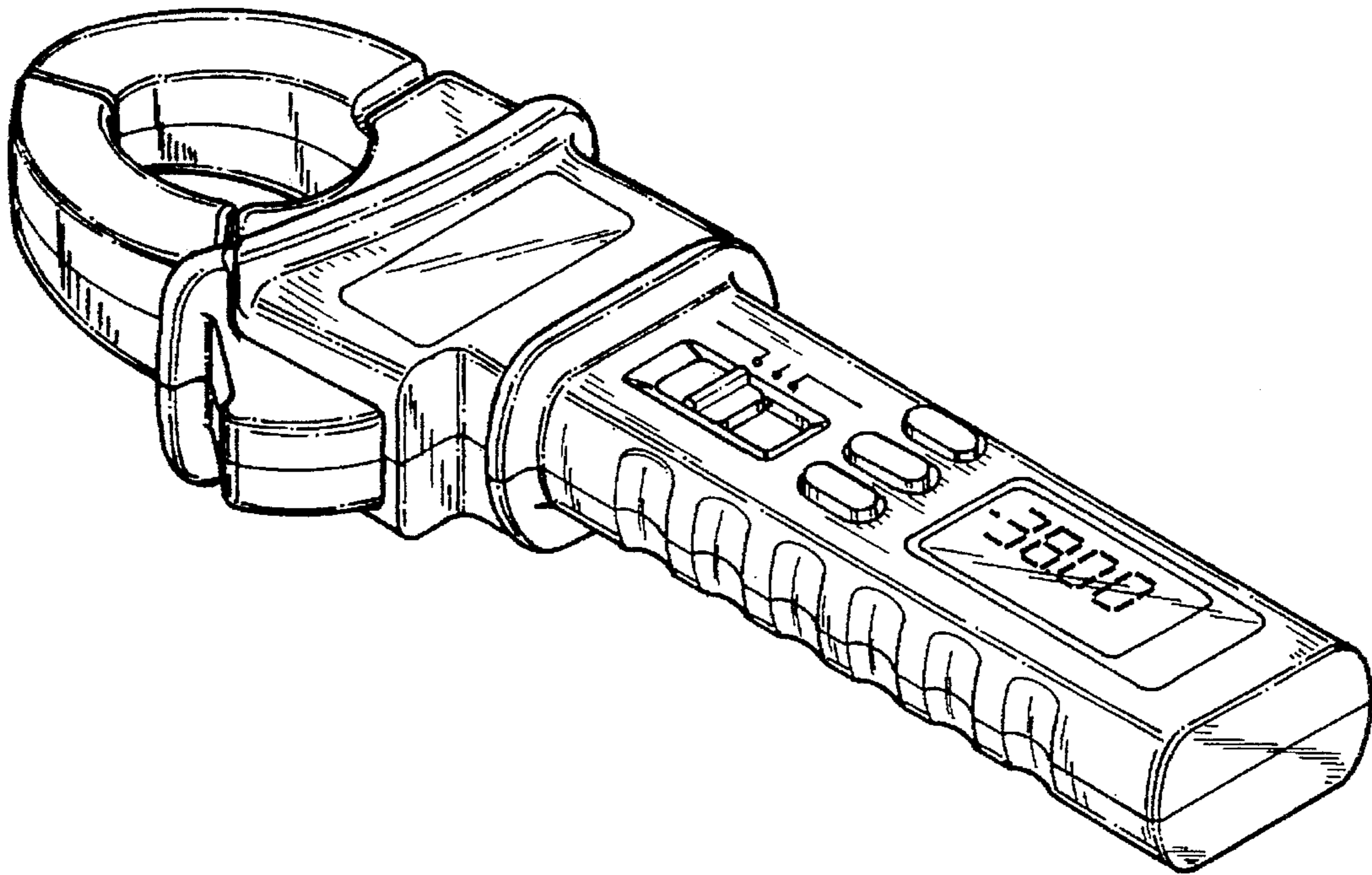
[57] **CLAIM**

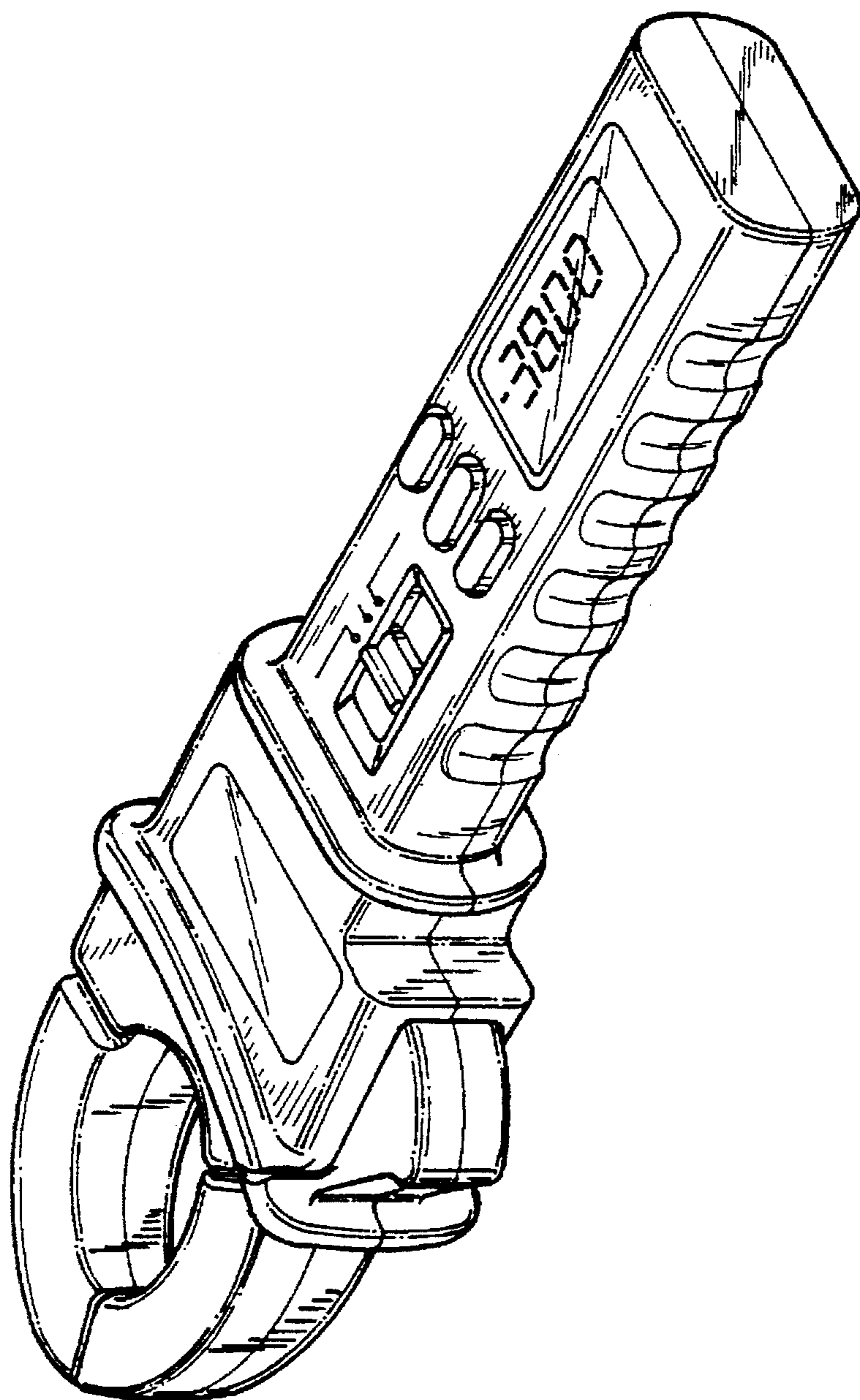
The ornamental design for an electrical multimeter, as shown and described.

**DESCRIPTION**

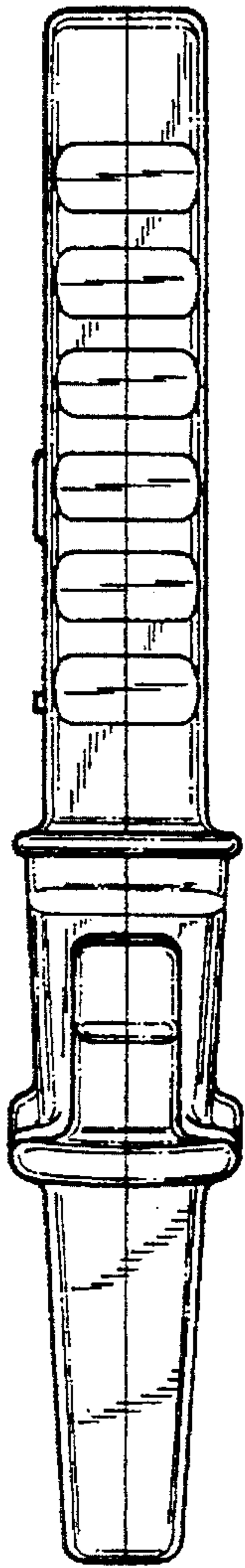
FIG. 1 is a perspective view of an electrical multimeter showing my new design;  
FIG. 2 is a front elevational view;  
FIG. 3 is a rear elevational view;  
FIG. 4 is a left side elevational view;  
FIG. 5 is a right side elevational view;  
FIG. 6 is a top plan view; and,  
FIG. 7 is a bottom plan view thereof.

**1 Claim, 5 Drawing Sheets**

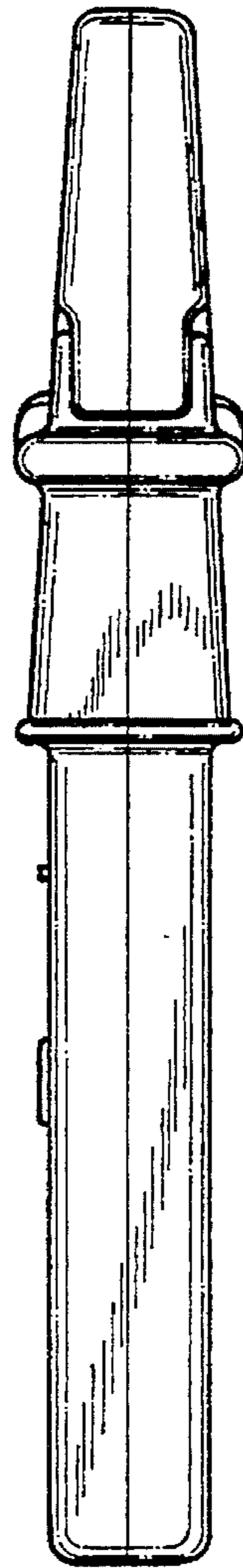




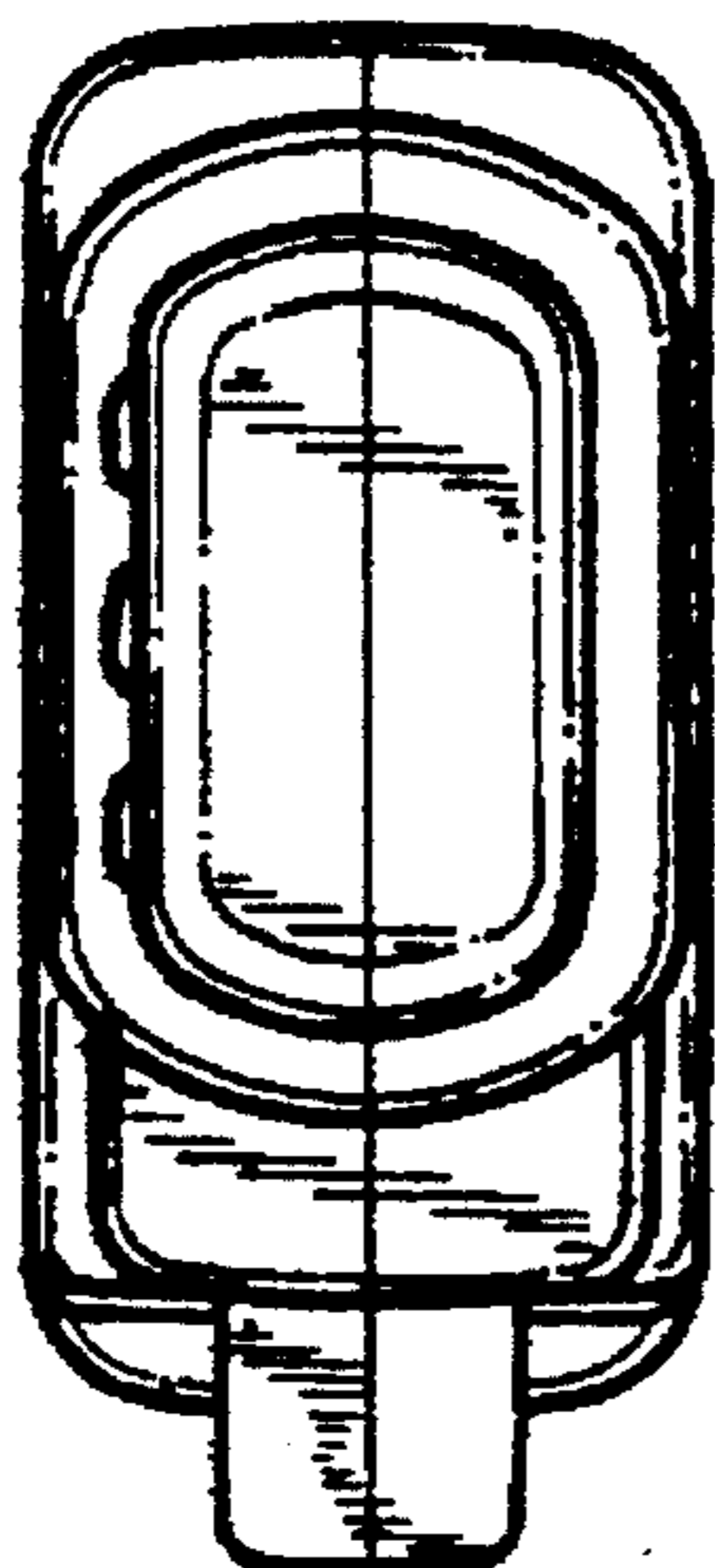
**FIG. 1**



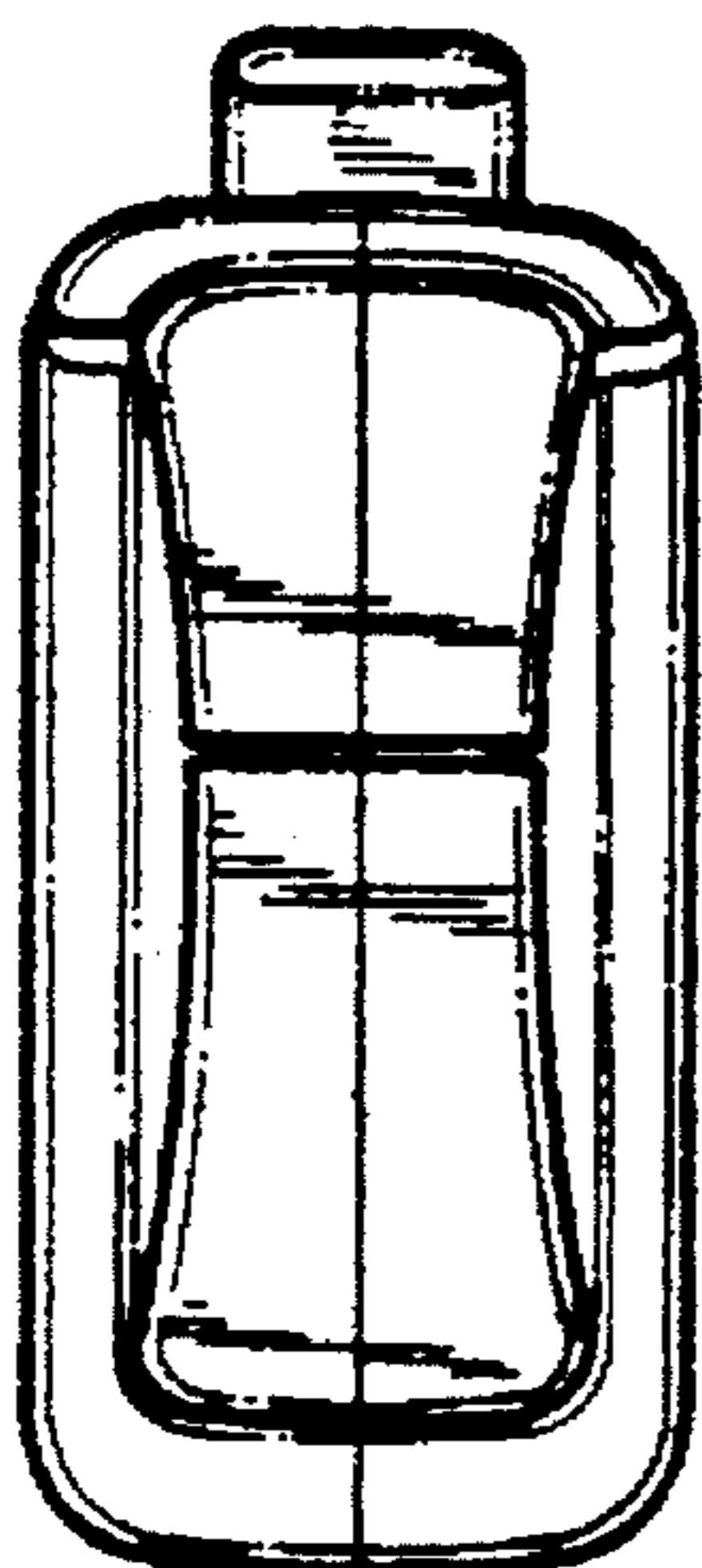
**FIG. 2**



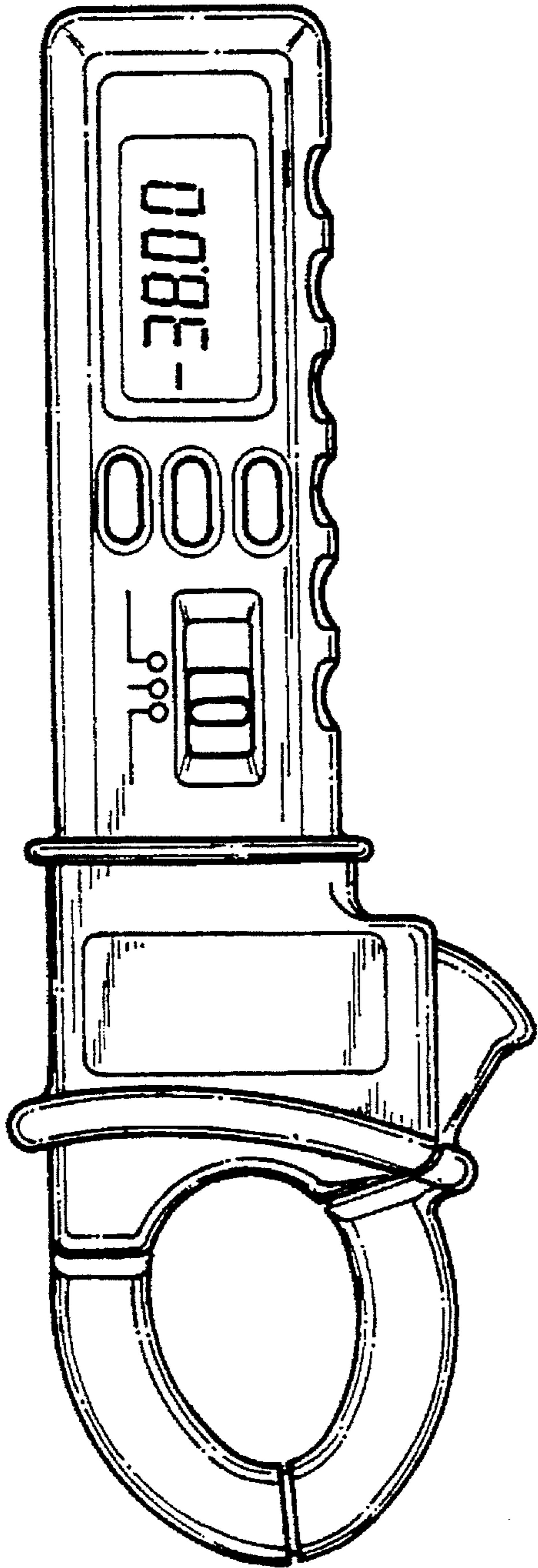
**FIG. 3**



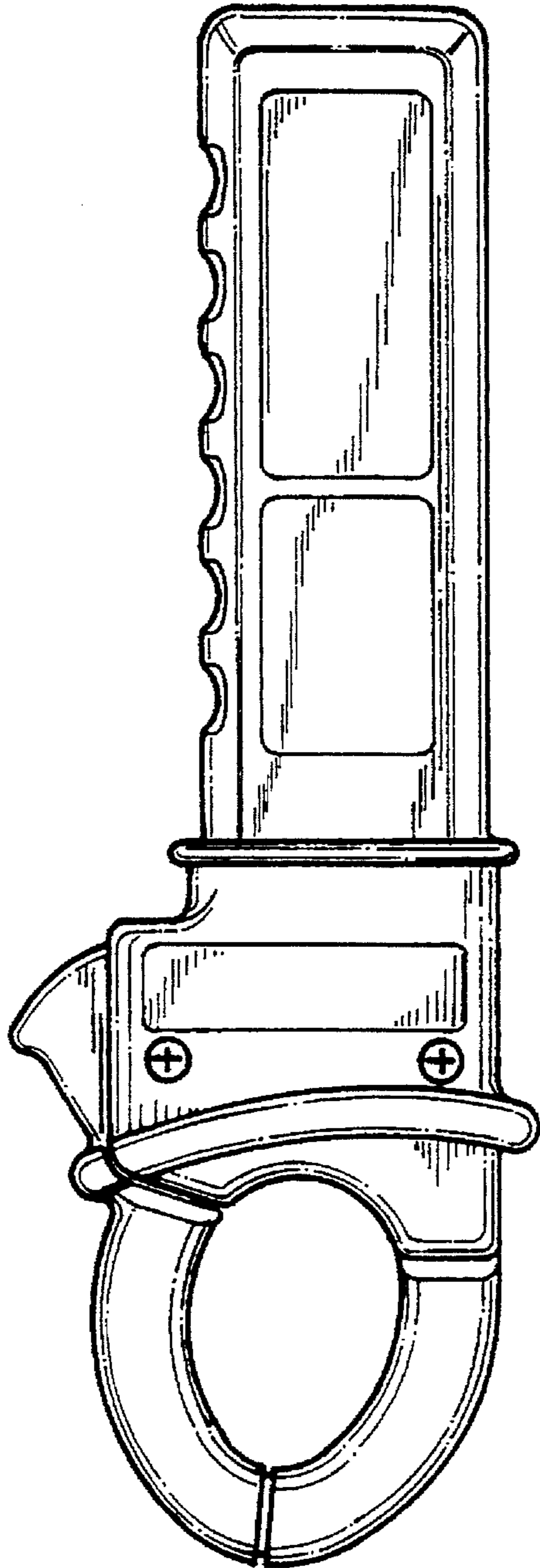
**FIG. 5**



**FIG. 4**



**FIG. 6**



**FIG. 7**