



US00D363366S

United States Patent [19]

Harding et al.

[11] Patent Number: **Des. 363,366**

[45] Date of Patent: ****Oct. 17, 1995**

[54] **DOUBLE RIDER HARNESS**

[76] Inventors: **Marilyn Harding; Joe Harding**, both of 480 Idaho St., Reno, Nev. 89506

[**] Term: **14 Years**

[21] Appl. No.: **21,676**

[22] Filed: **Apr. 12, 1994**

[52] U.S. Cl. **D29/101**

[58] Field of Search D29/100, 101; D2/626, 829; 2/2, 44, 230, 301, 310, 338; 182/3-4; 128/875-876; 362/108; 119/770; 297/275

[56] **References Cited**

U.S. PATENT DOCUMENTS

D. 339,216 9/1993 Evans D29/101

D. 342,348 12/1993 Panarelli D29/101
3,004,519 10/1961 Weissman 182/4
4,751,923 6/1988 Marino 128/878

Primary Examiner—Ruth McInroy
Attorney, Agent, or Firm—H. Jay Spiegel

[57] **CLAIM**

The ornamental design for a double rider harness, as shown and described.

DESCRIPTION

FIG. 1 is a perspective view of a double rider harness showing our new design;
FIG. 2 is a front elevational view thereof;
FIG. 3 is a rear elevational view thereof;
FIG. 4 is a left side elevational view thereof; and,
FIG. 5 is a right side elevational view thereof.

1 Claim, 2 Drawing Sheets

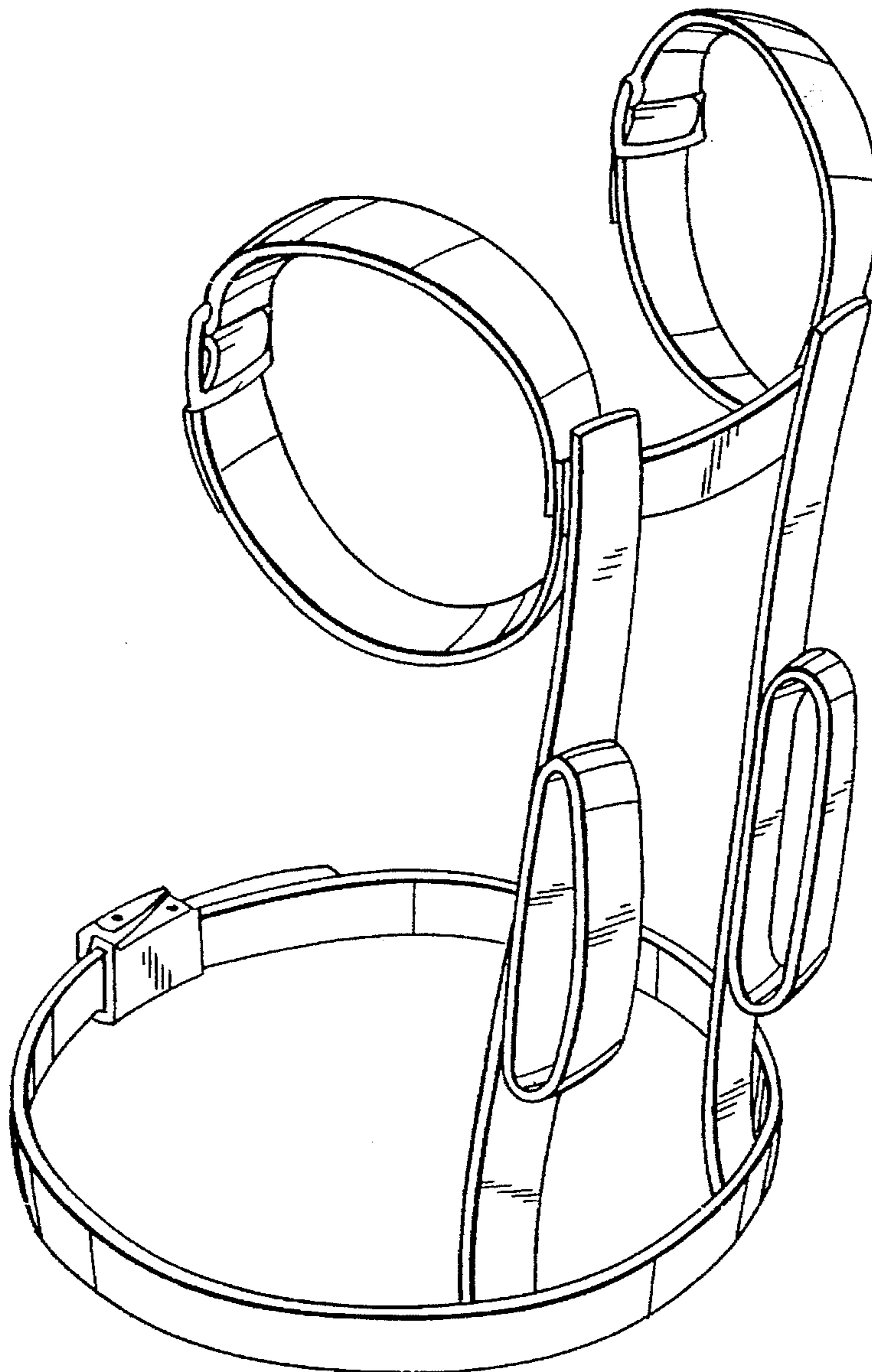

FIG. 1

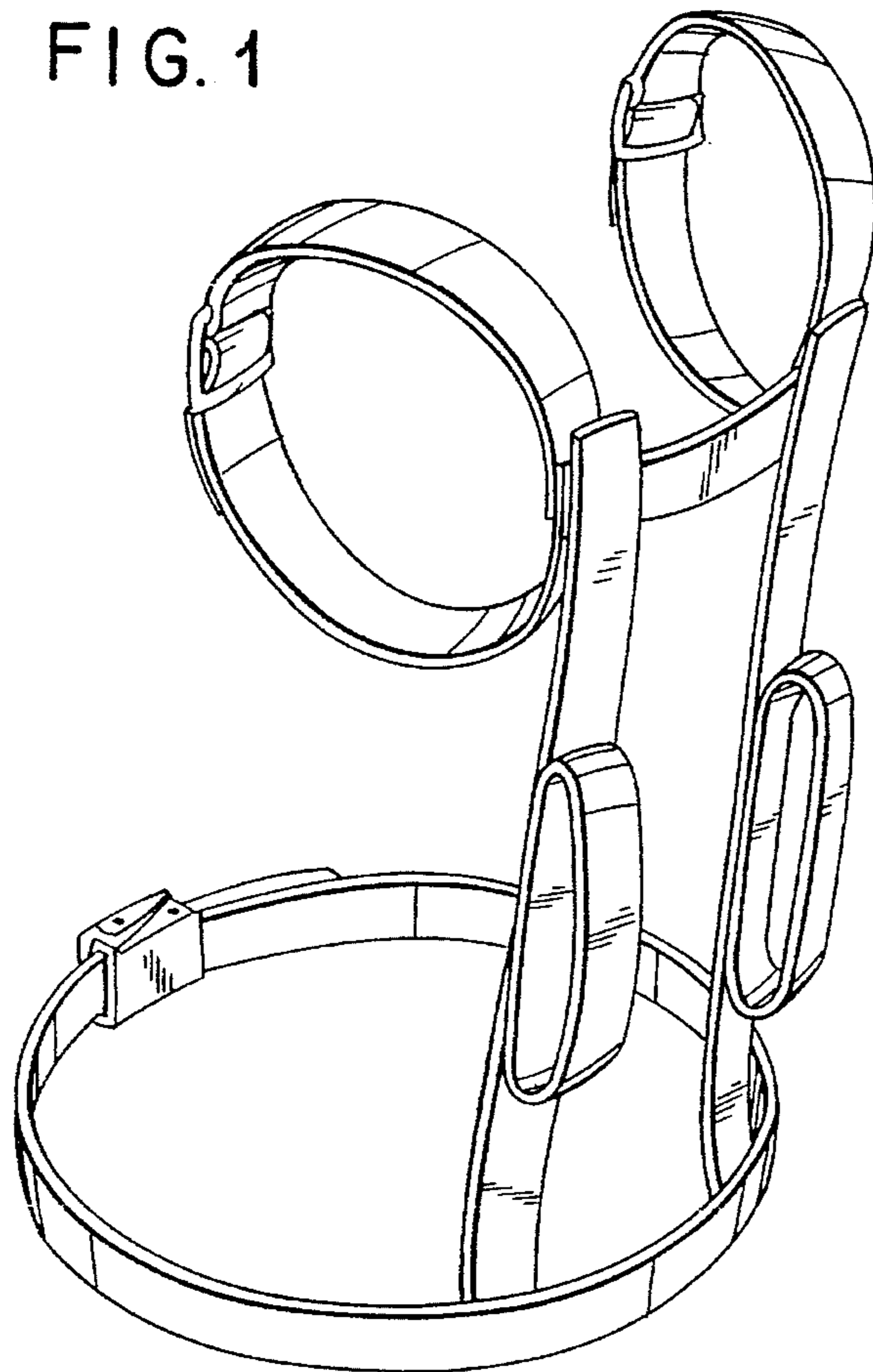

FIG. 2

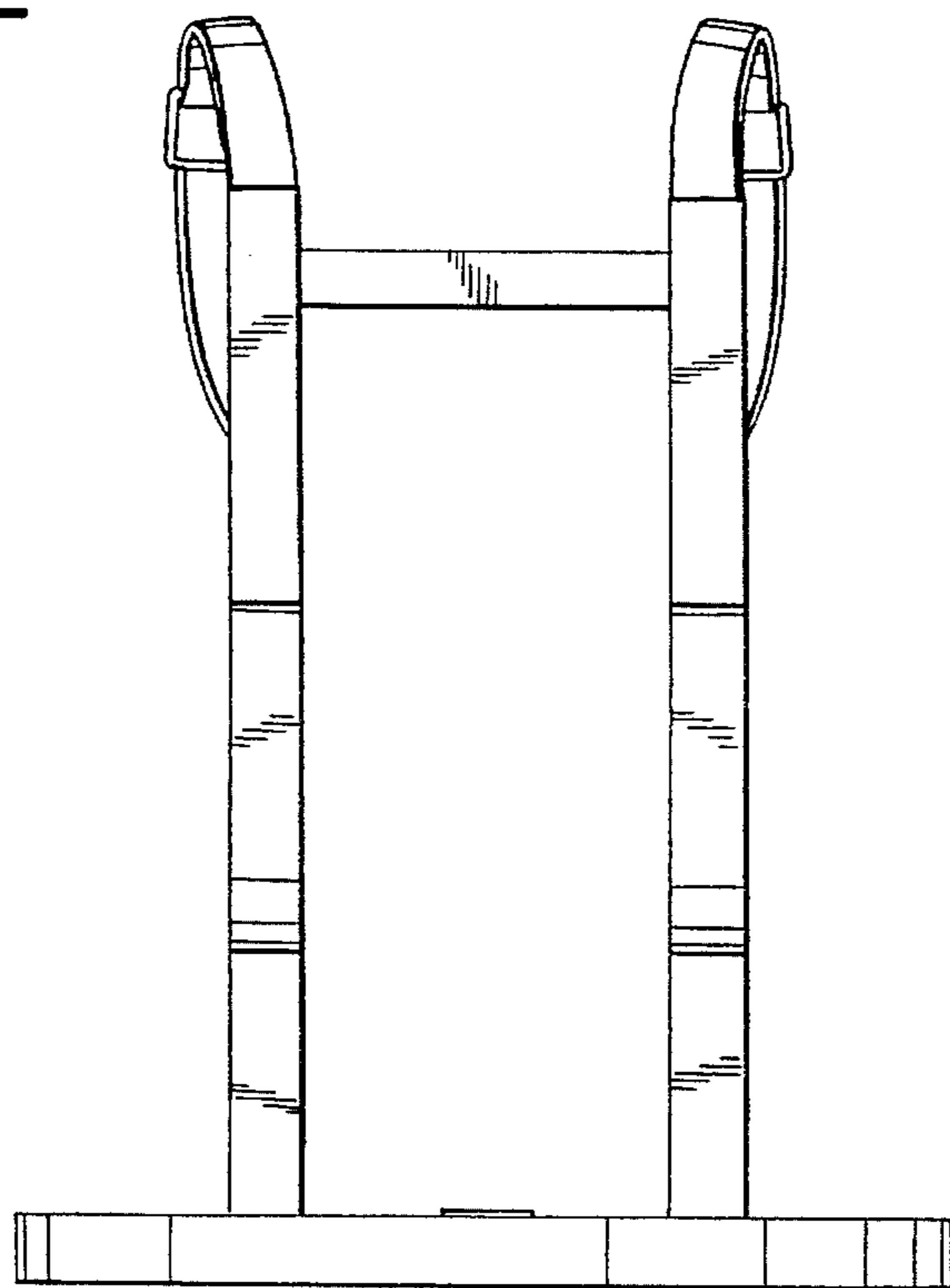

FIG. 3

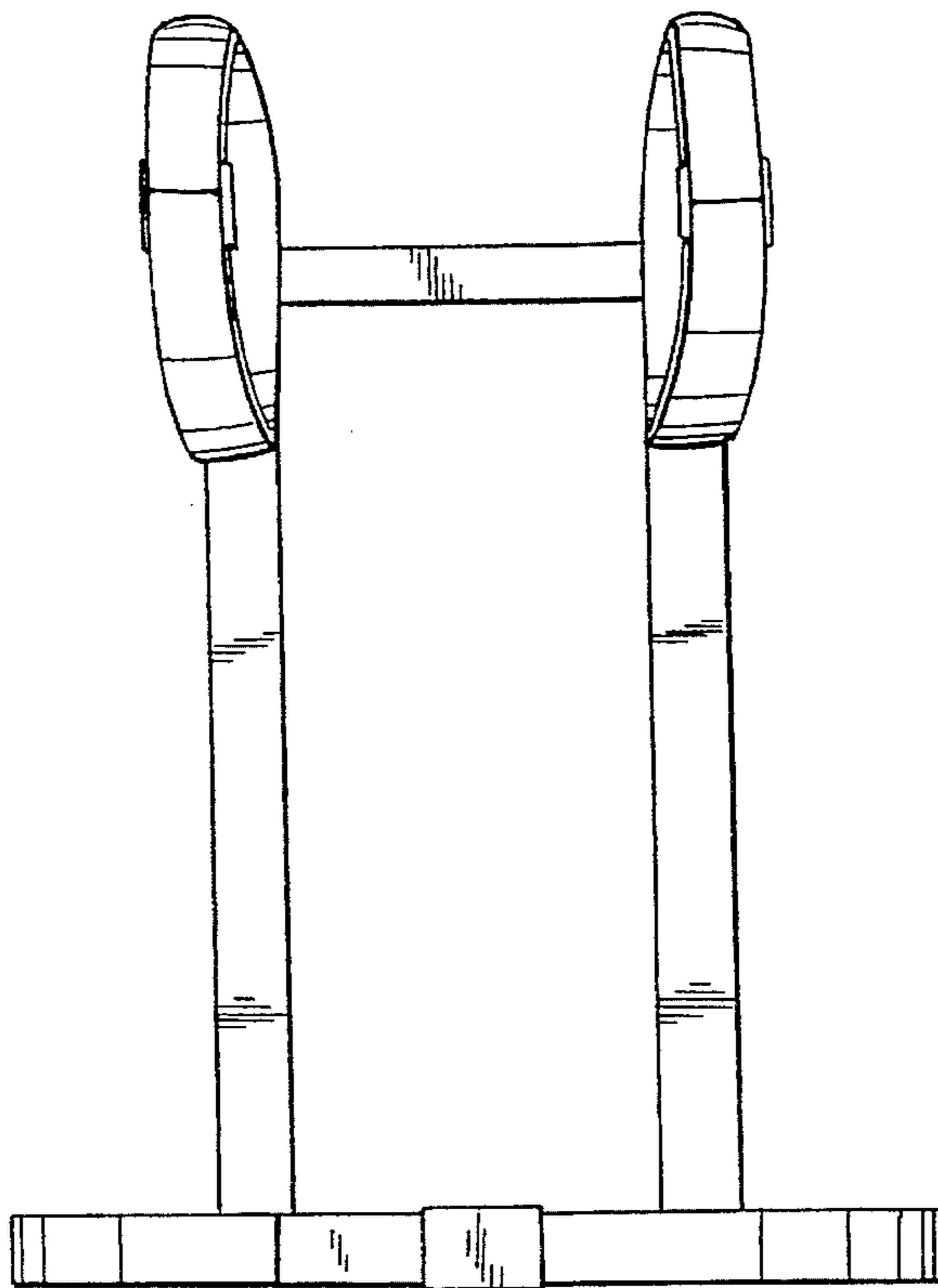

FIG. 4

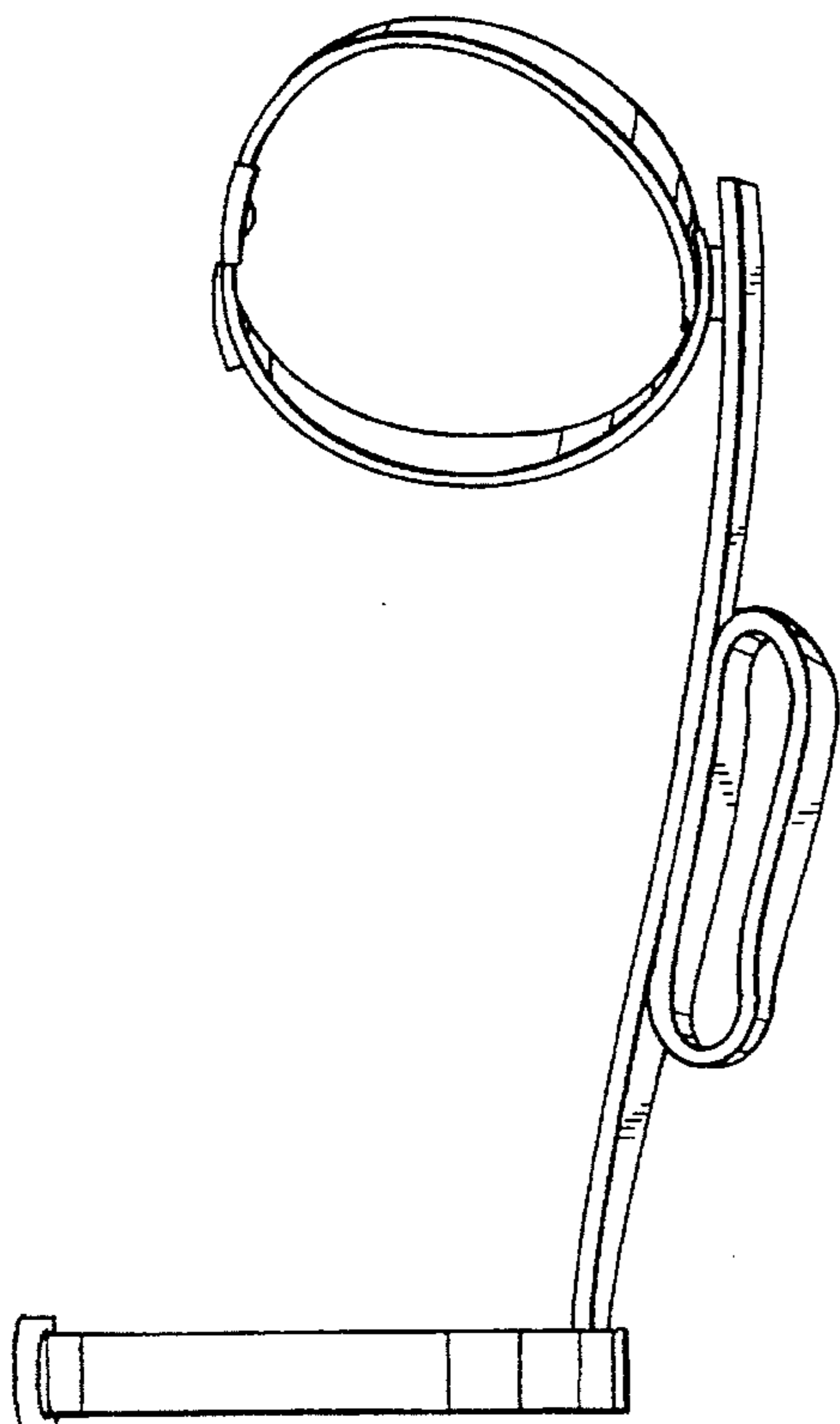

FIG. 5

