



US00D363264S

United States Patent [19]
Mullin

[11] **Patent Number: Des. 363,264**
[45] **Date of Patent: **Oct. 17, 1995**

[54] **MOTOR FOR A BOAT WINDSHIELD WIPER**

[75] Inventor: **James B. Mullin**, Danville, Calif.

[73] Assignee: **AFI, Inc.**, Napa, Calif.

[**] Term: **14 Years**

[21] Appl. No.: **17,178**

[22] Filed: **Jan. 6, 1994**

[52] **U.S. Cl.** **D12/220; D12/317**

[58] **Field of Search** **D12/219-220,**
D12/317; D13/112; 15/250.05, 250.06,
250.07, 250.32, 250.33, 250.35, 250.36,
250.41, 250.42, 250.12, 250.13, 250.16;
91/7, 218

[56] **References Cited**

U.S. PATENT DOCUMENTS

D. 170,709	10/1953	Lund	D13/112
D. 342,225	12/1993	Heckman et al.	D12/220
4,776,057	10/1988	Beneteau et al.	15/250.31 X
4,959,883	10/1990	Eustache	15/250.16 X
5,264,766	11/1993	Tracht et al.	15/250.16 X
5,271,121	12/1993	Dolegouski	15/250.12 X

Primary Examiner—Melanie H. Tung
Attorney, Agent, or Firm—Thomas R. Lampe

[57] **CLAIM**

The ornamental design for a motor for a boat windshield wiper, as shown and described.

DESCRIPTION

FIG. 1 is a front perspective view of a motor for a boat

windshield wiper showing my new design;

FIG. 2 is a rear perspective view thereof, the broken line drawing of a wiper attachment spindle is for illustrative purposes only forms no part of the claimed design;

FIG. 3 is a front elevation view thereof;

FIG. 4 is a top plan view thereof;

FIG. 5 is a rear elevation view thereof;

FIG. 6 is a bottom view thereof;

FIG. 7 is a right end view thereof;

FIG. 8 is a left end view thereof;

FIG. 9 is a front perspective view of a second embodiment of a motor for a boat windshield wiper showing my new design;

FIG. 10 is a rear perspective view thereof, the broken line drawing of a wiper attachment spindle is for illustrative purposes only and forms no part of the claimed design;

FIG. 11 is a front elevation view thereof;

FIG. 12 is a top plan view thereof;

FIG. 13 is a rear elevation view thereof;

FIG. 14 is a bottom view thereof;

FIG. 15 is a right end view thereof; and,

FIG. 16 is a left end view thereof.

1 Claim, 4 Drawing Sheets

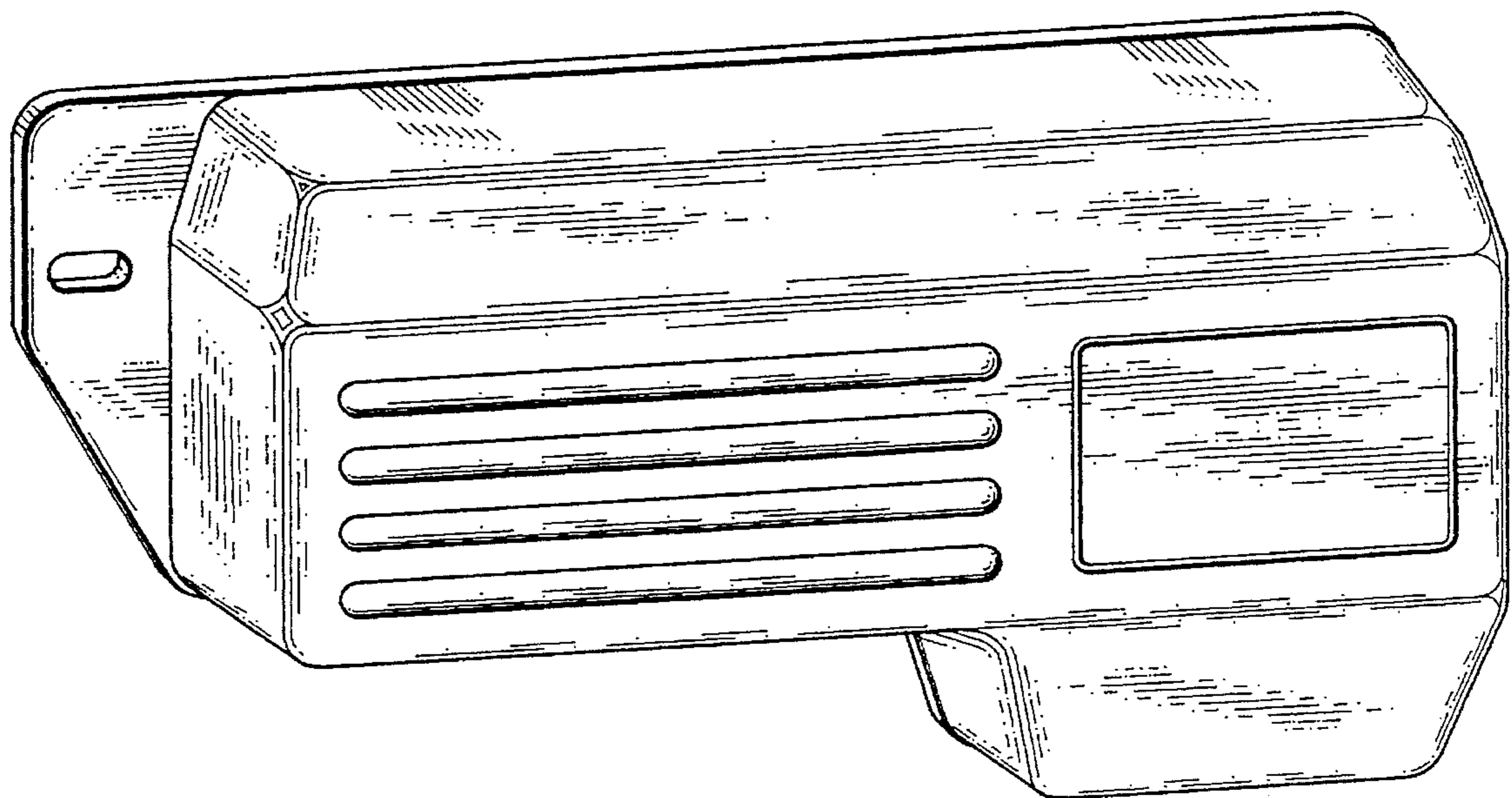

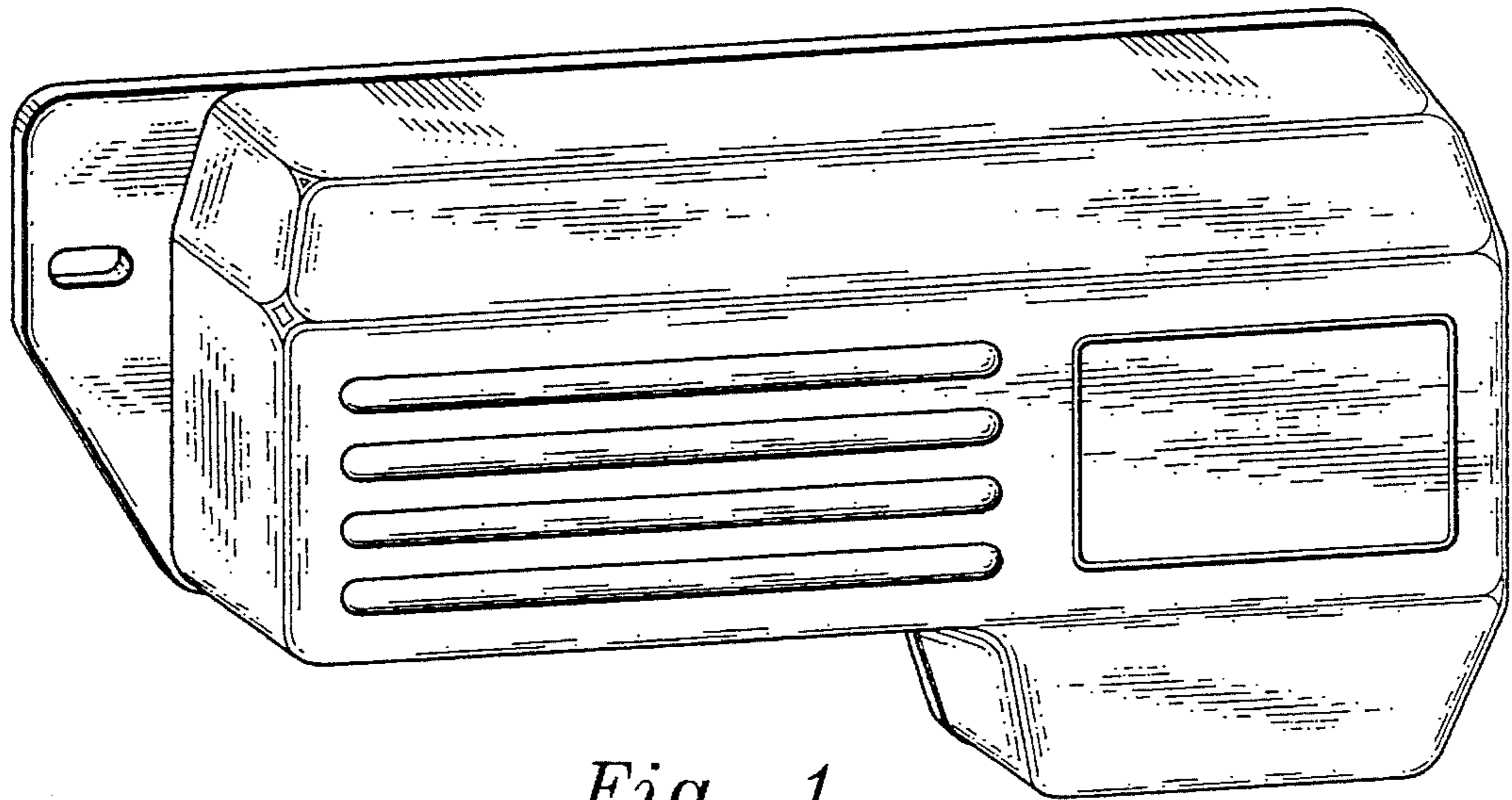

Fig. 1

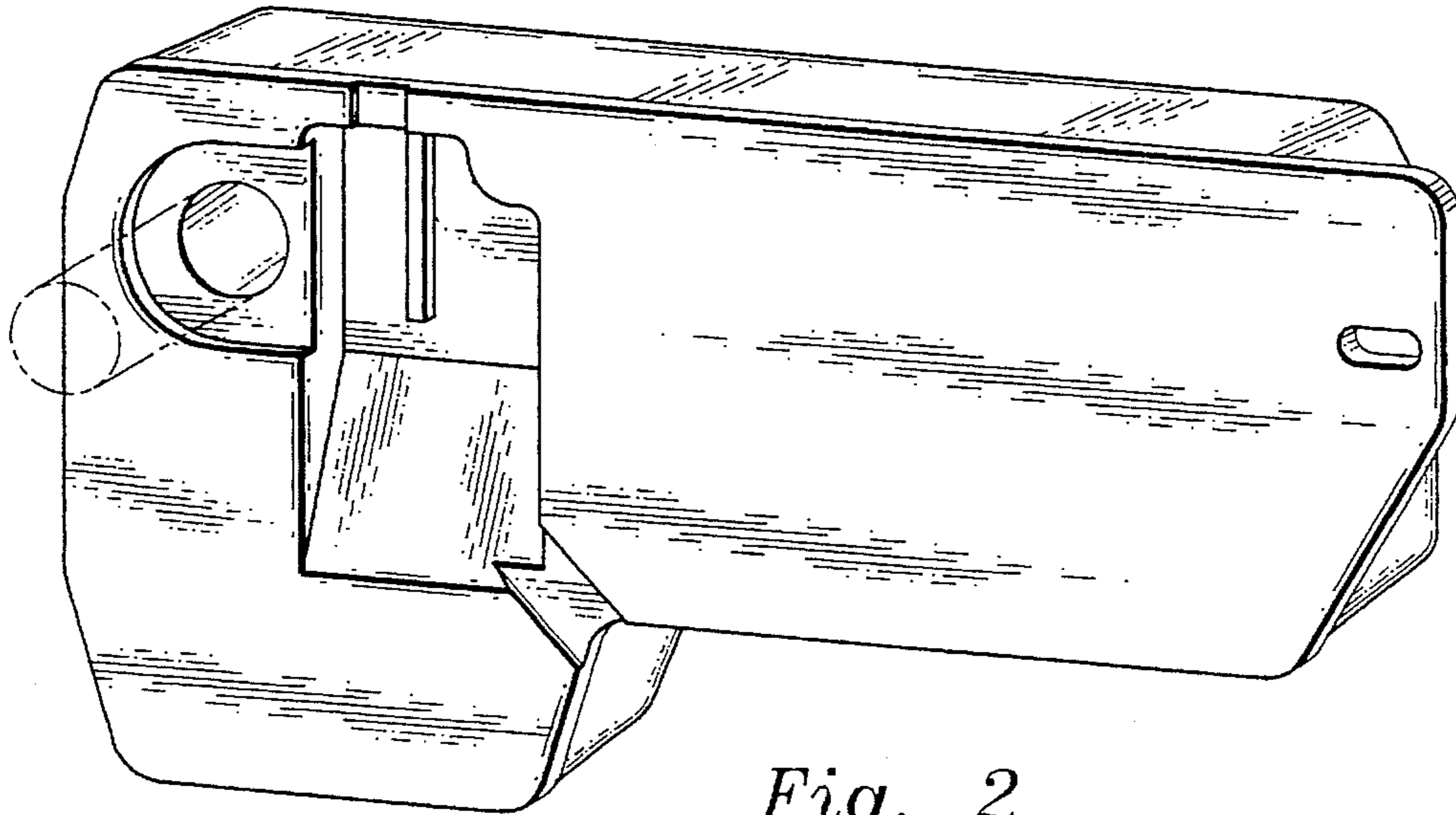

Fig. 2

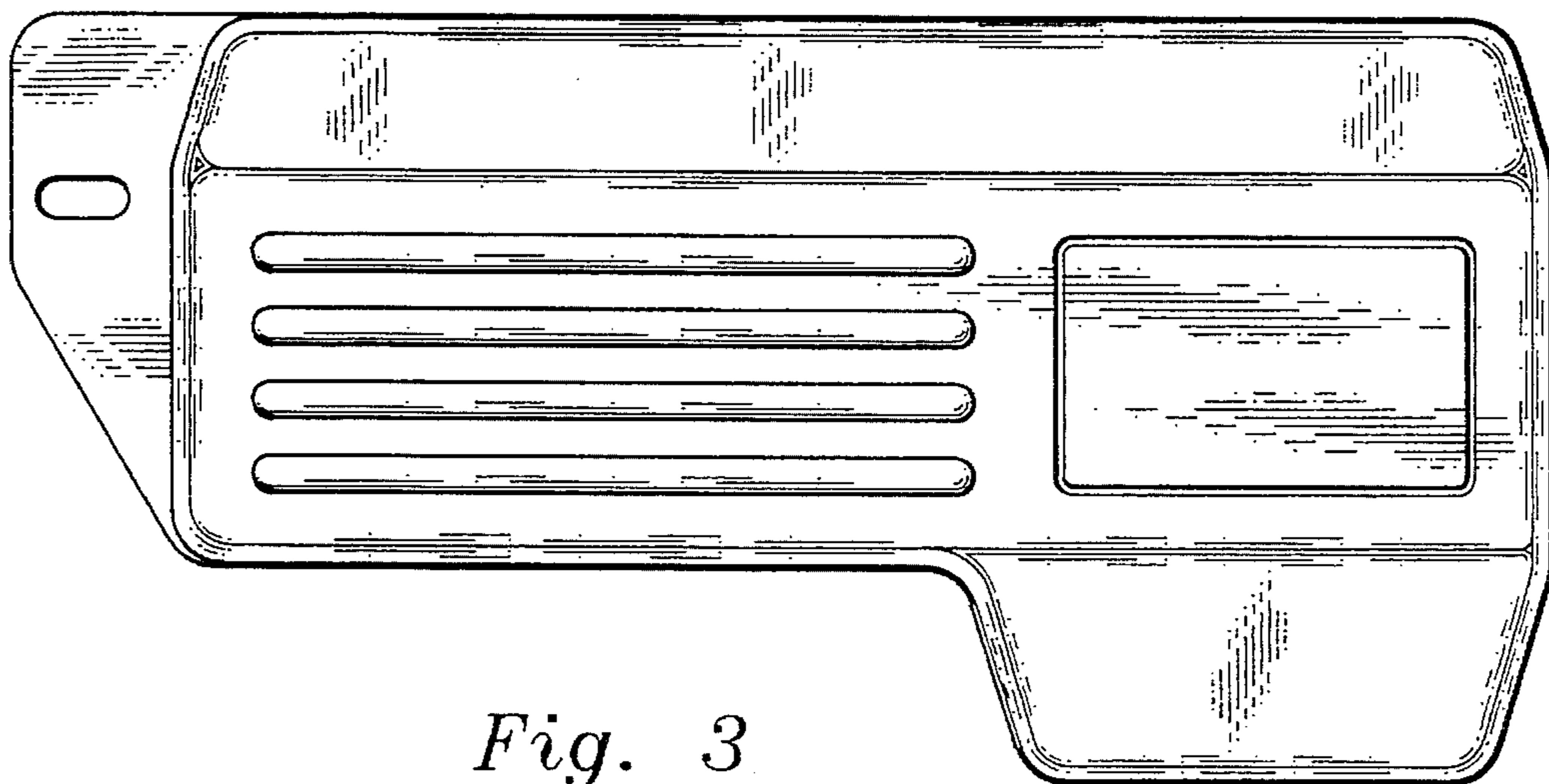

Fig. 3

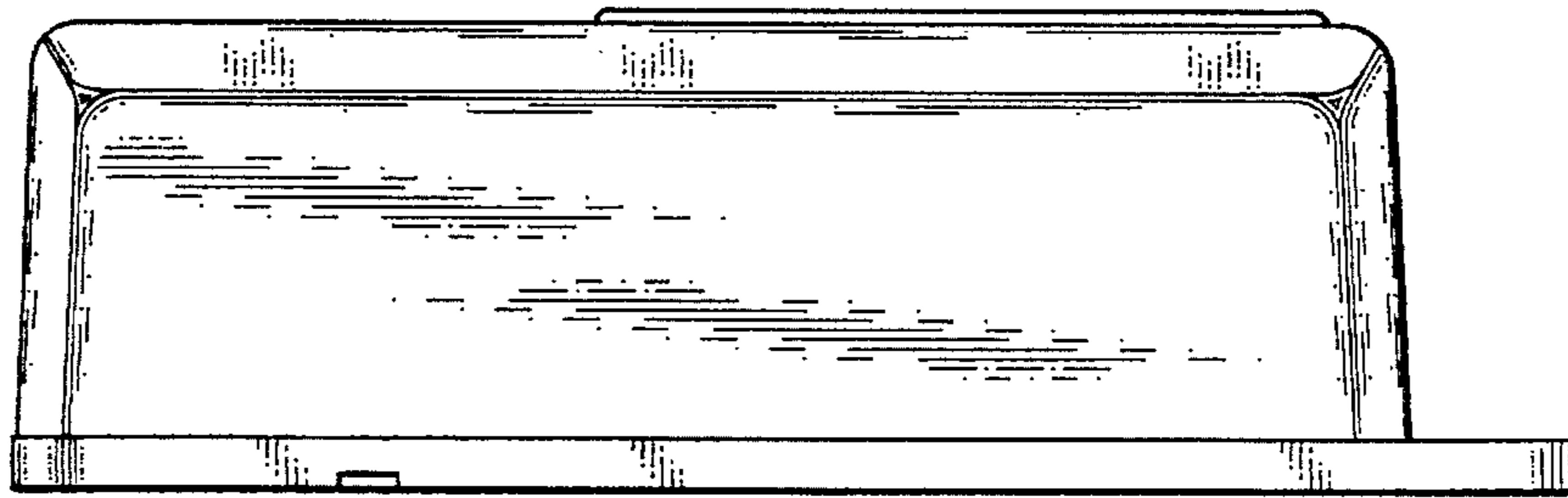

Fig. 4

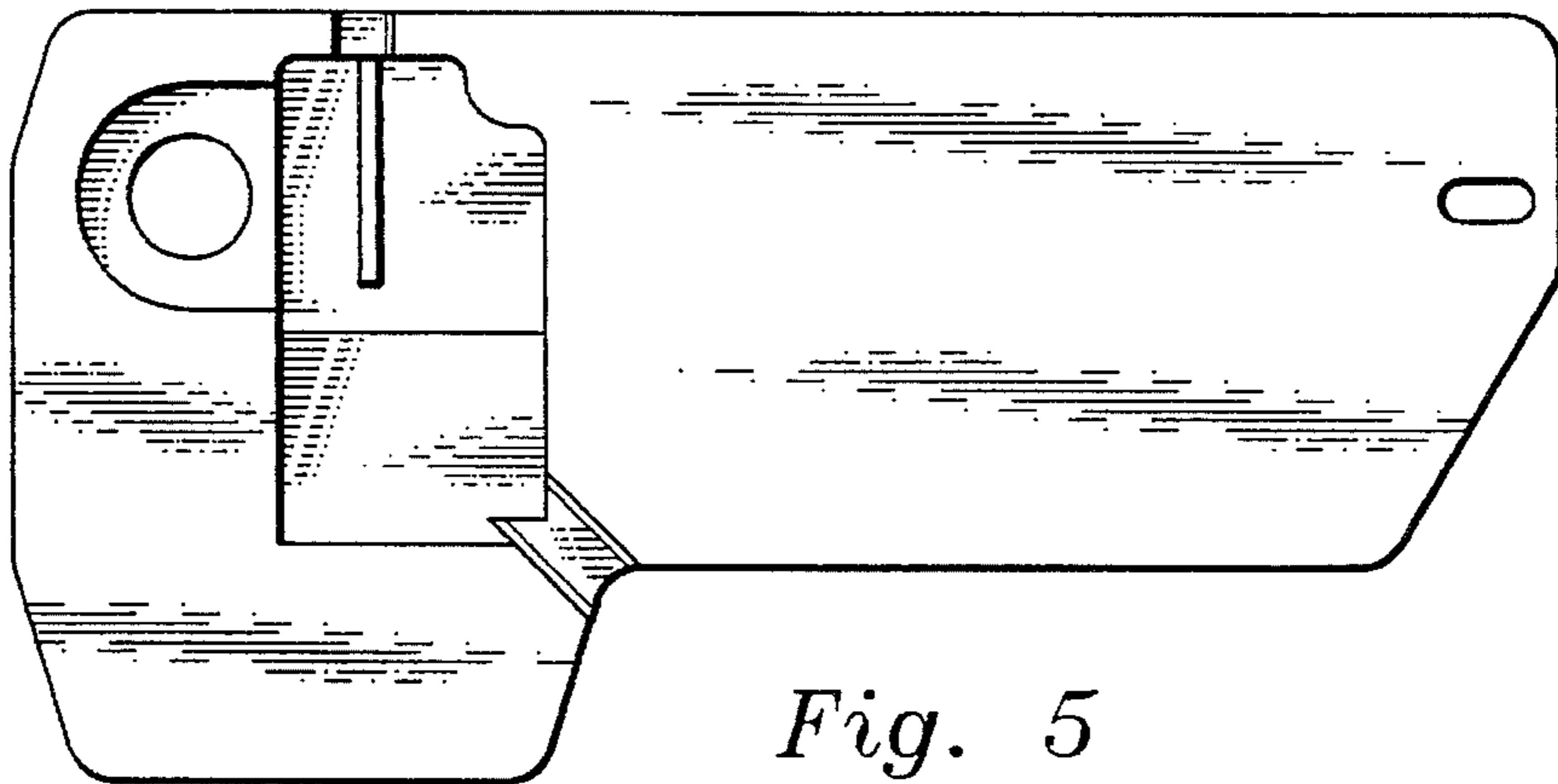

Fig. 5

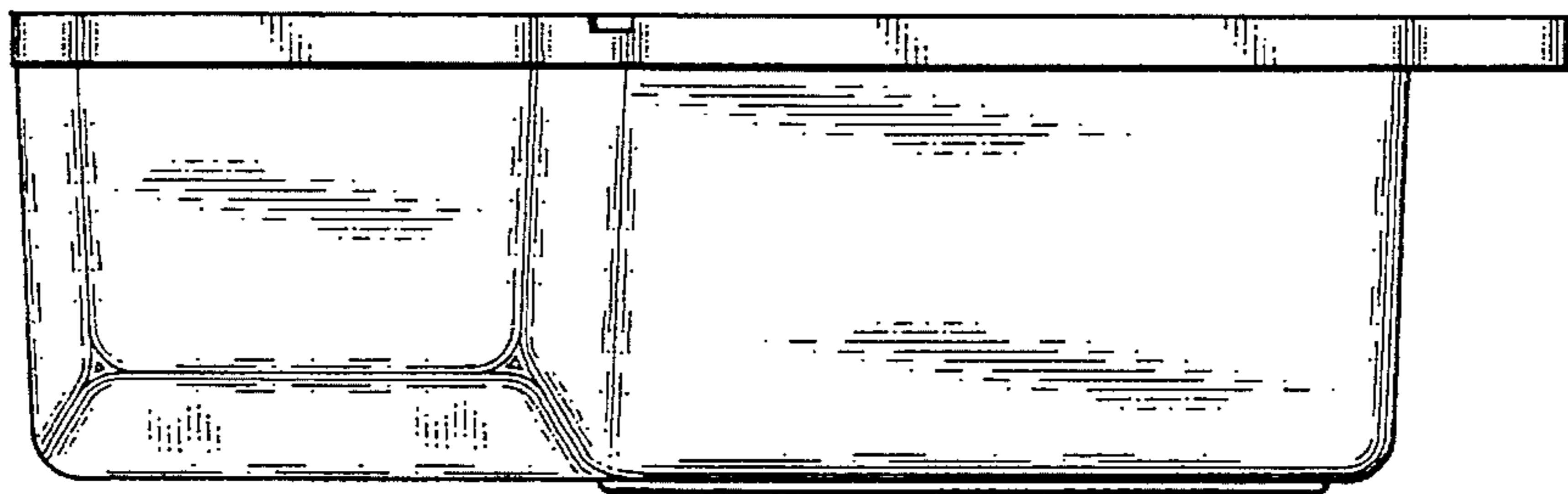

Fig. 6

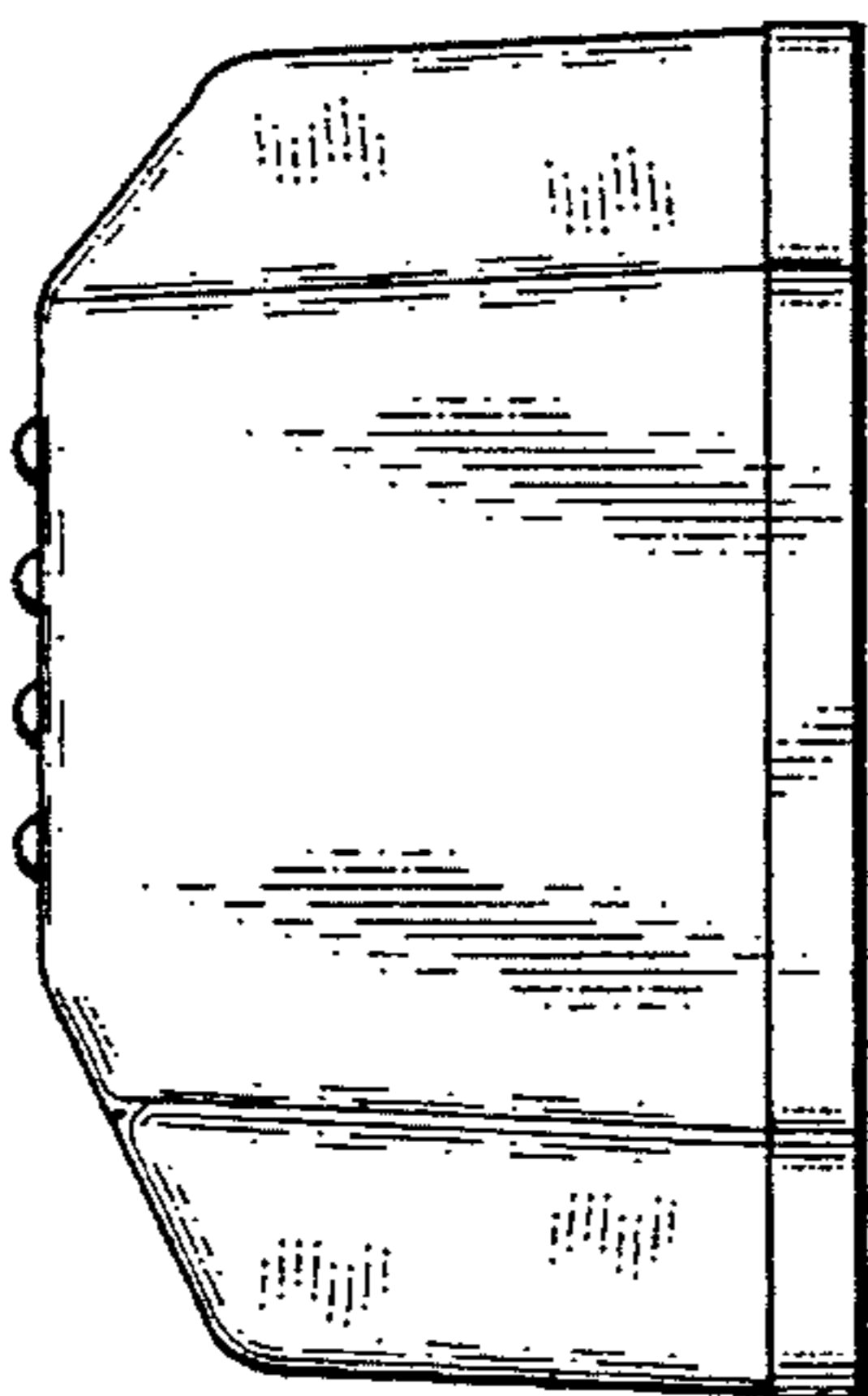

Fig. 7

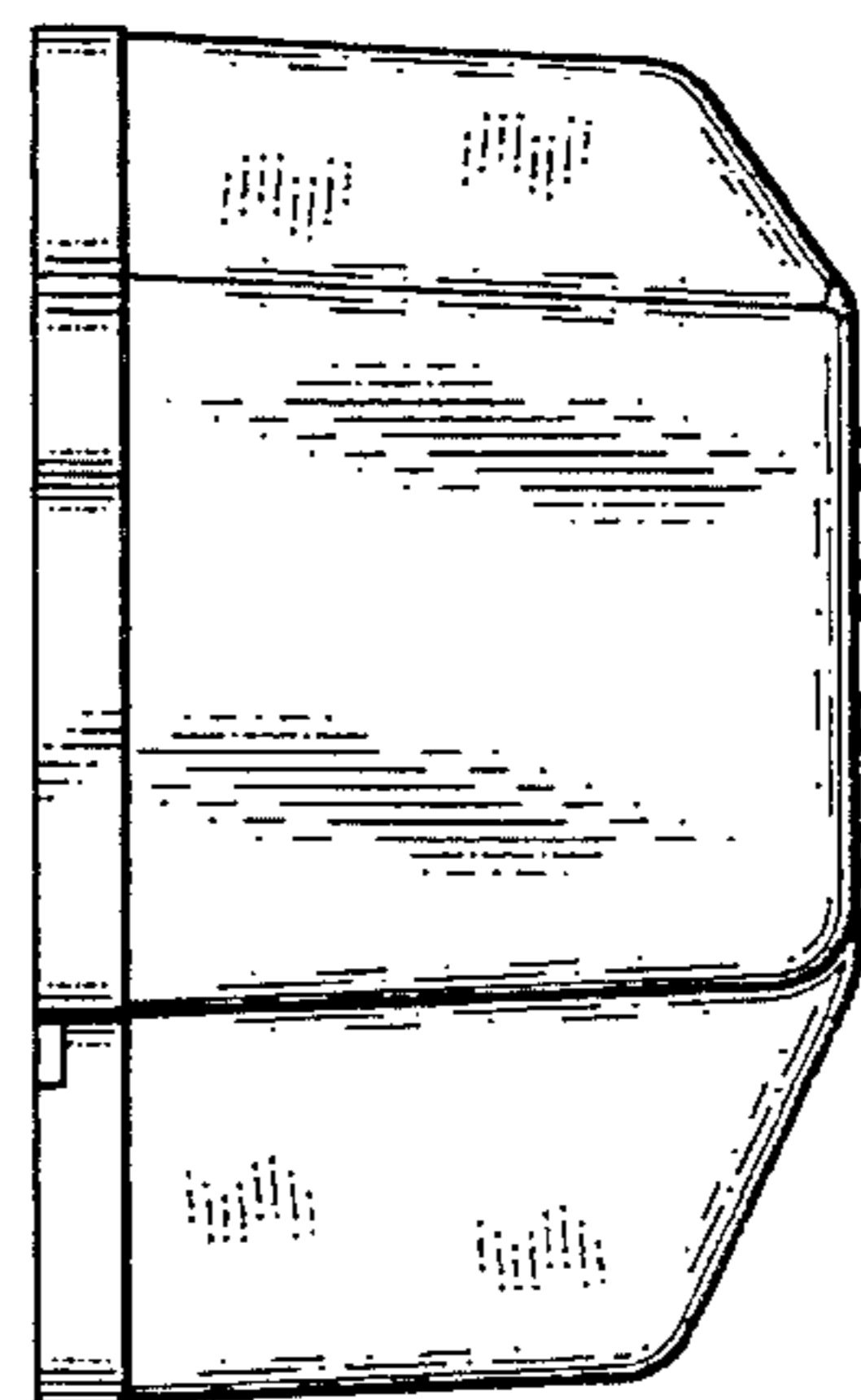

Fig. 8

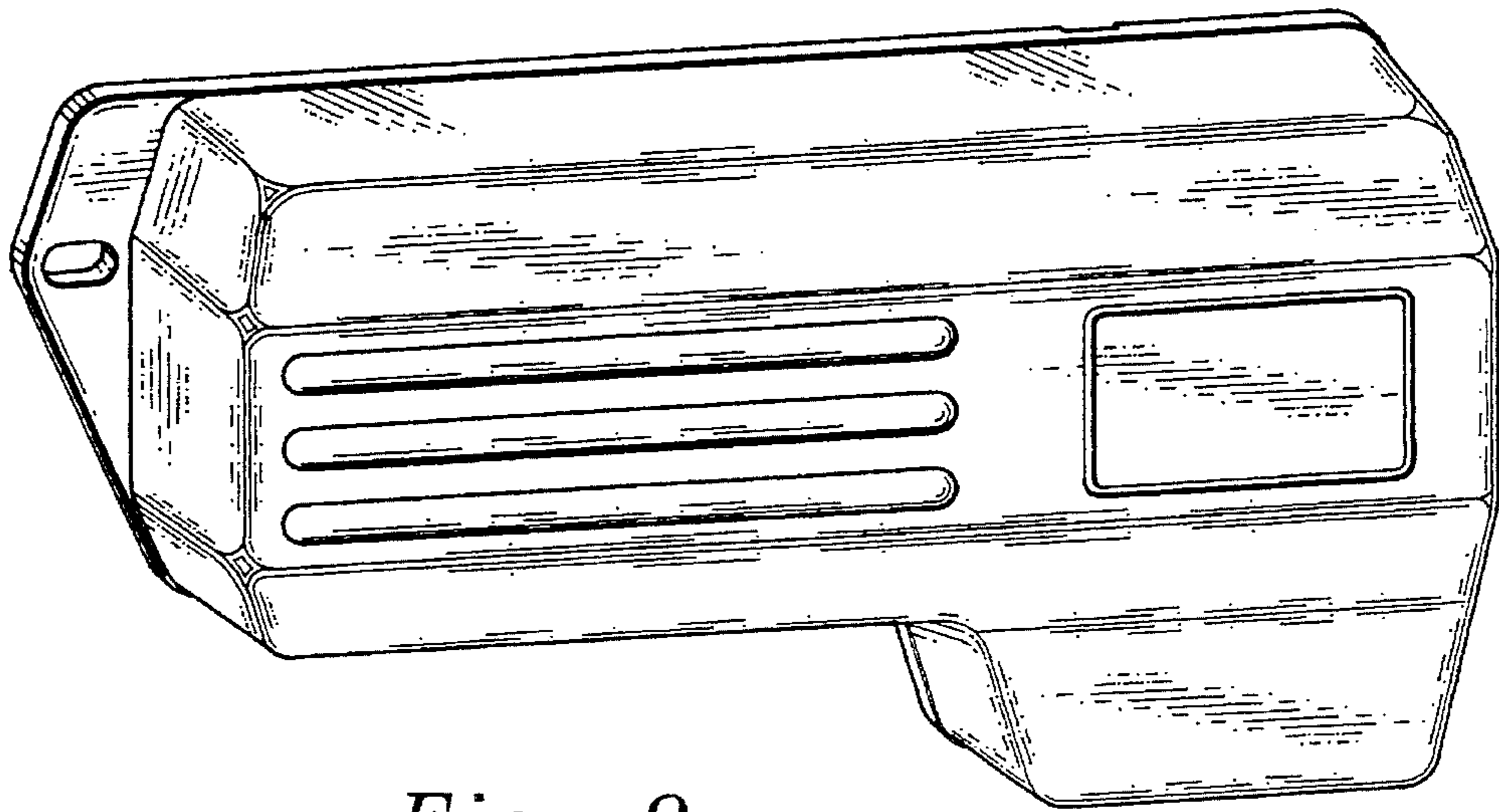

Fig. 9

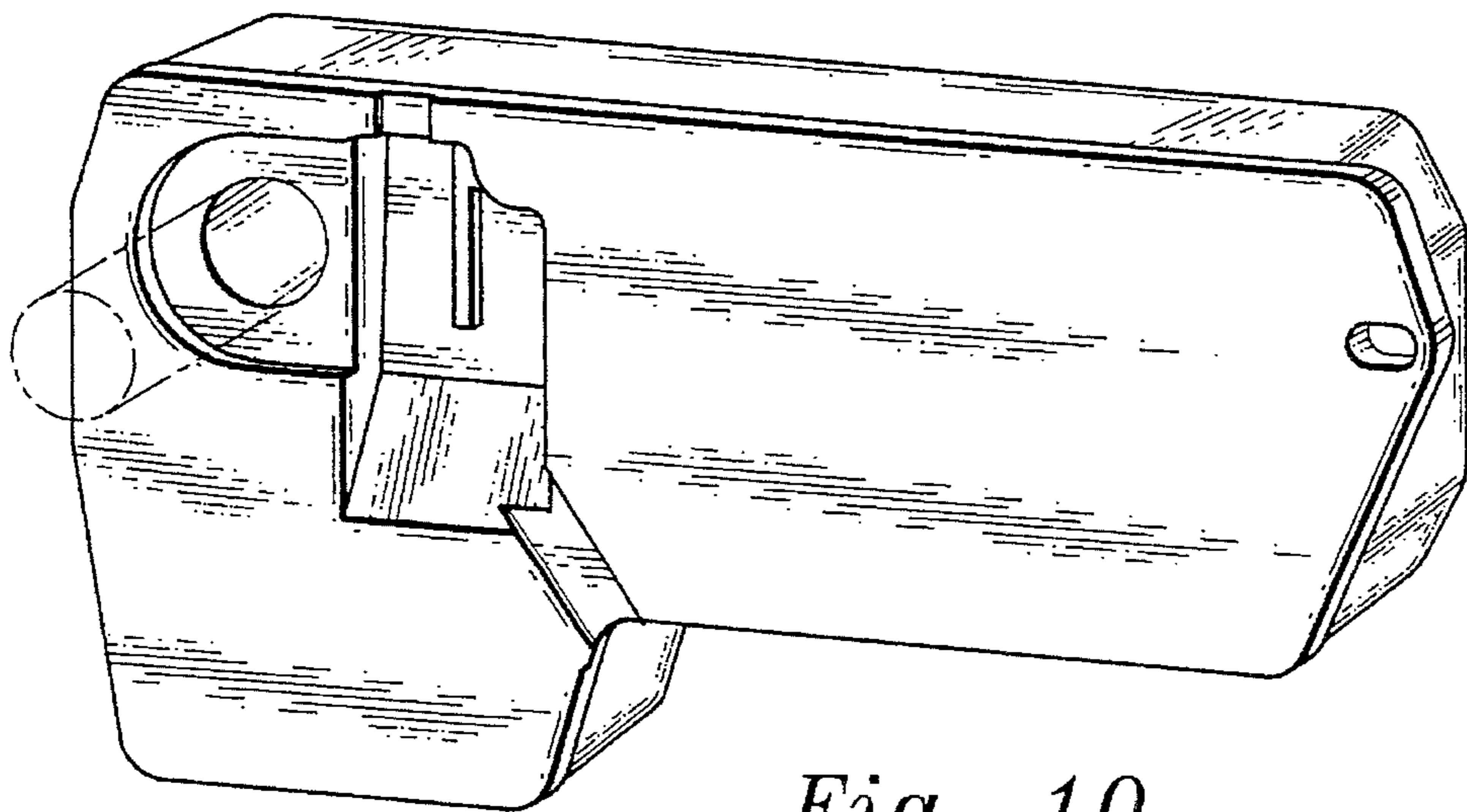

Fig. 10

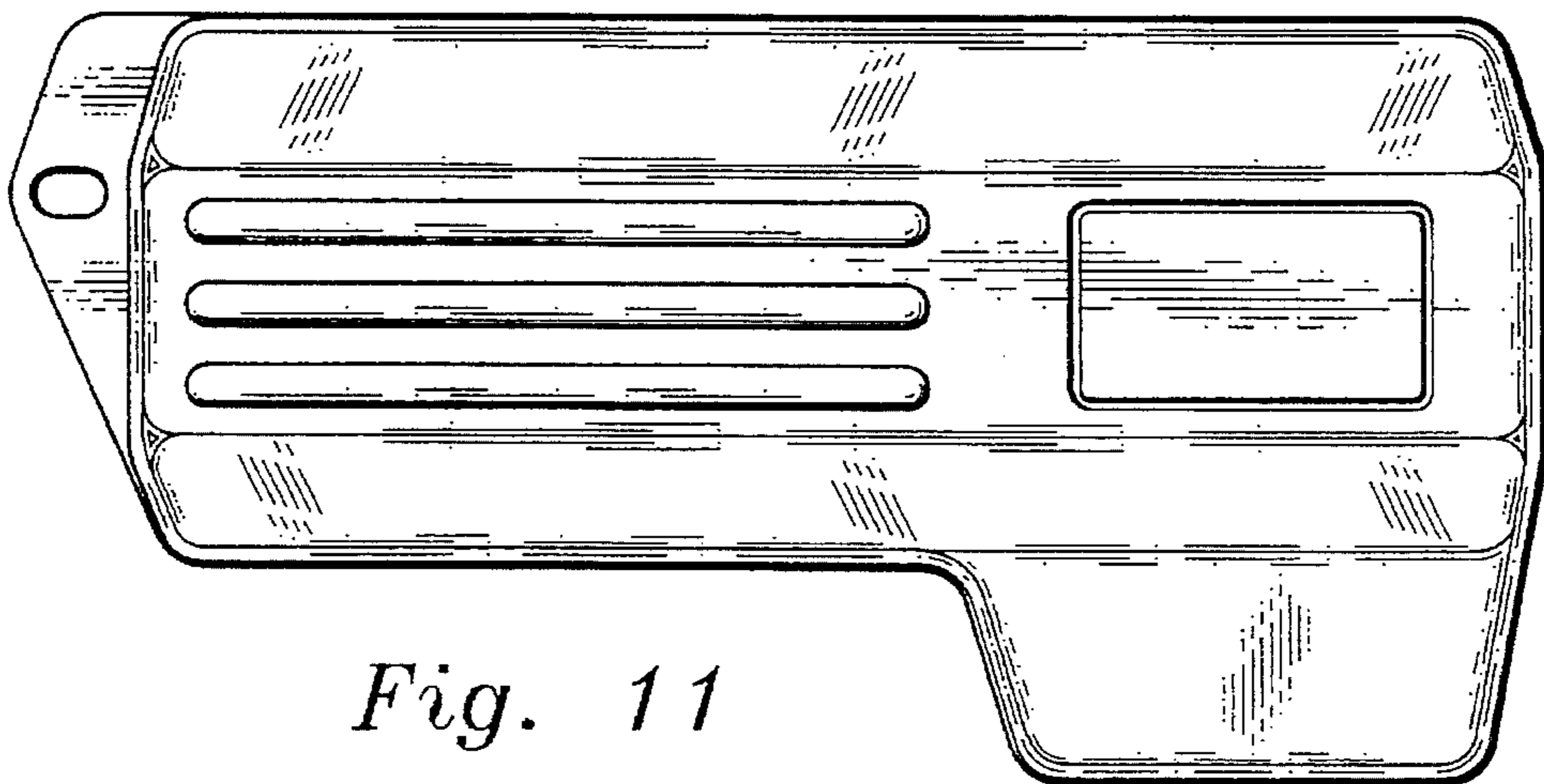

Fig. 11

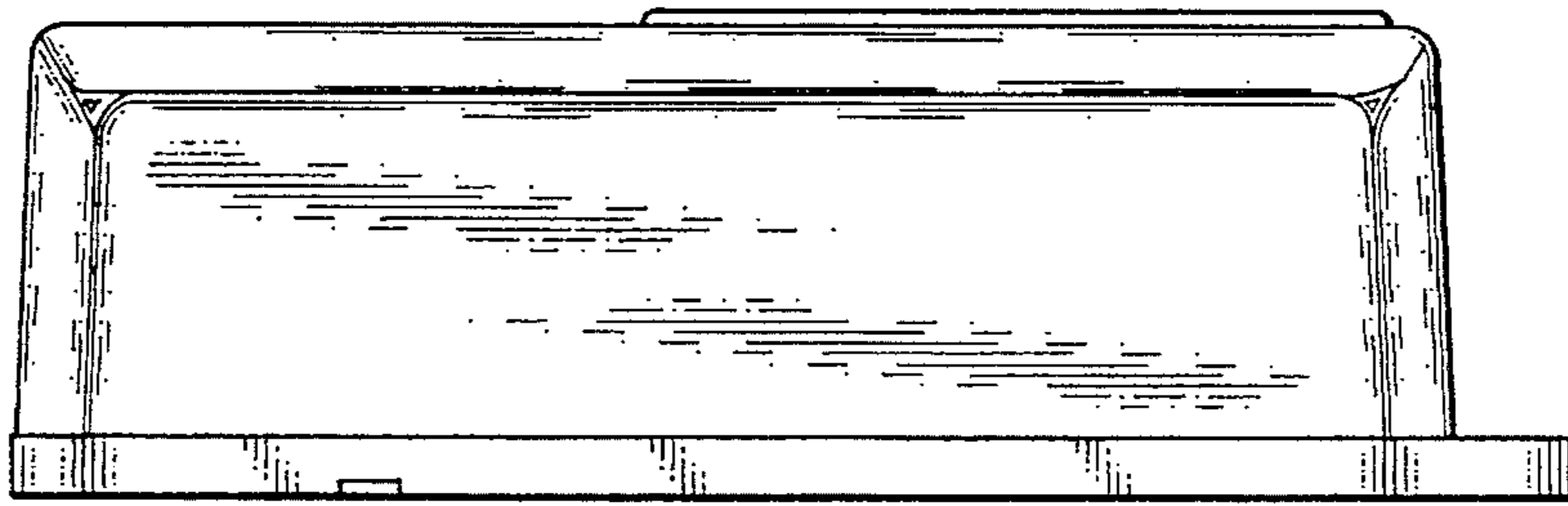

Fig. 12

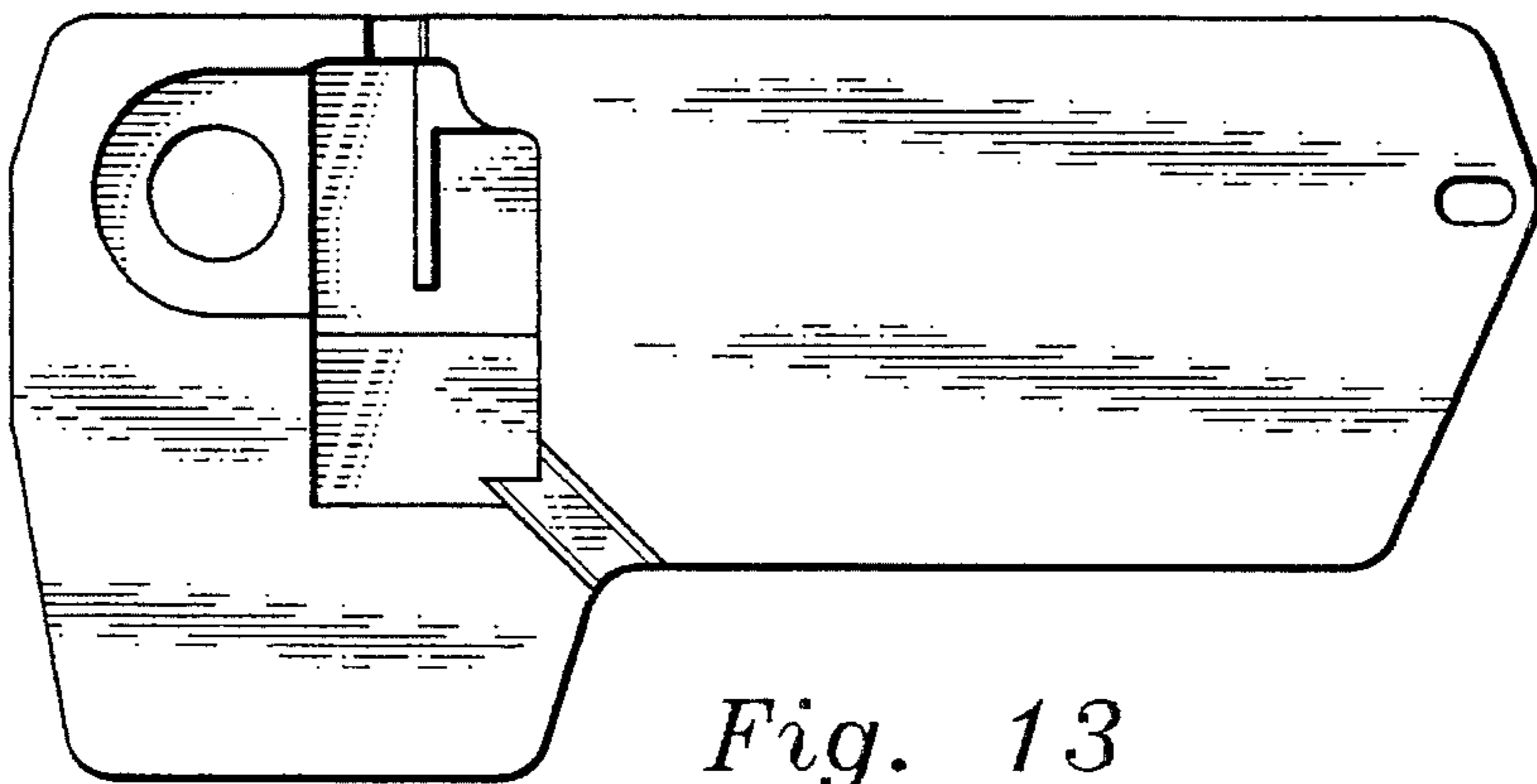

Fig. 13

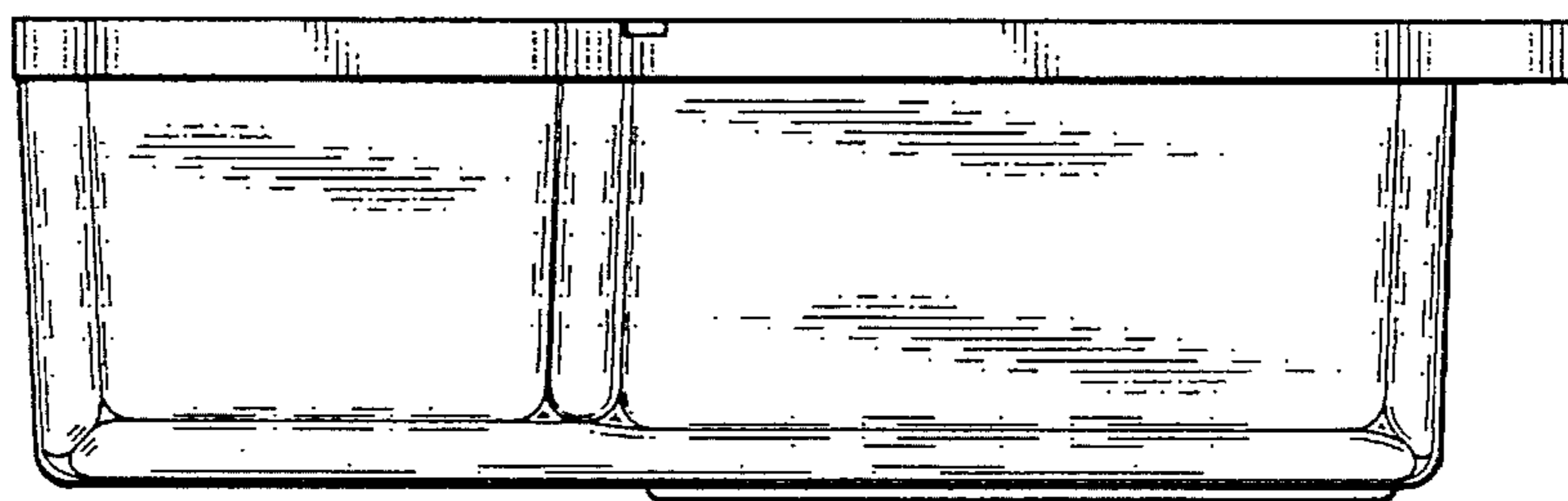

Fig. 14

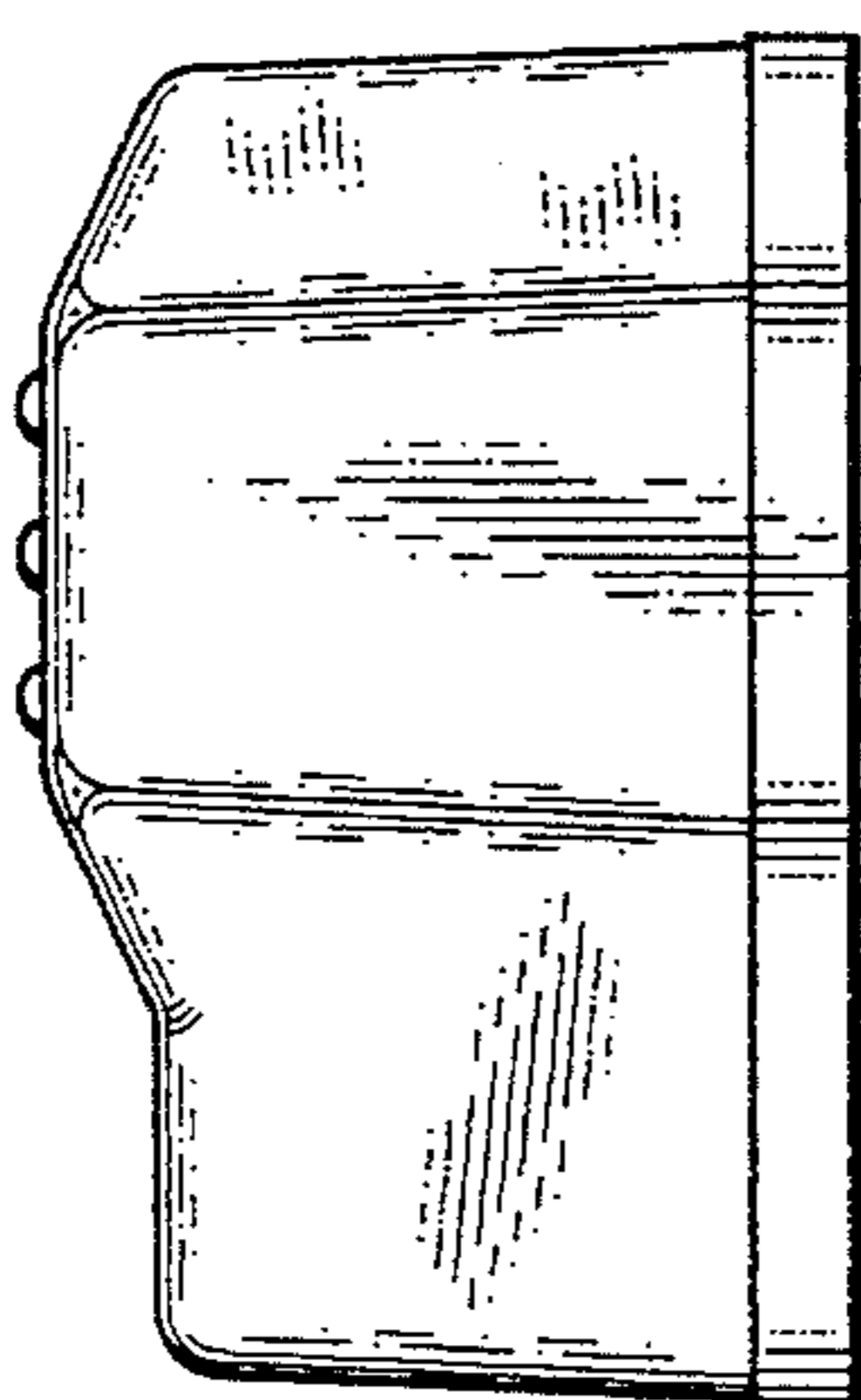

Fig. 15

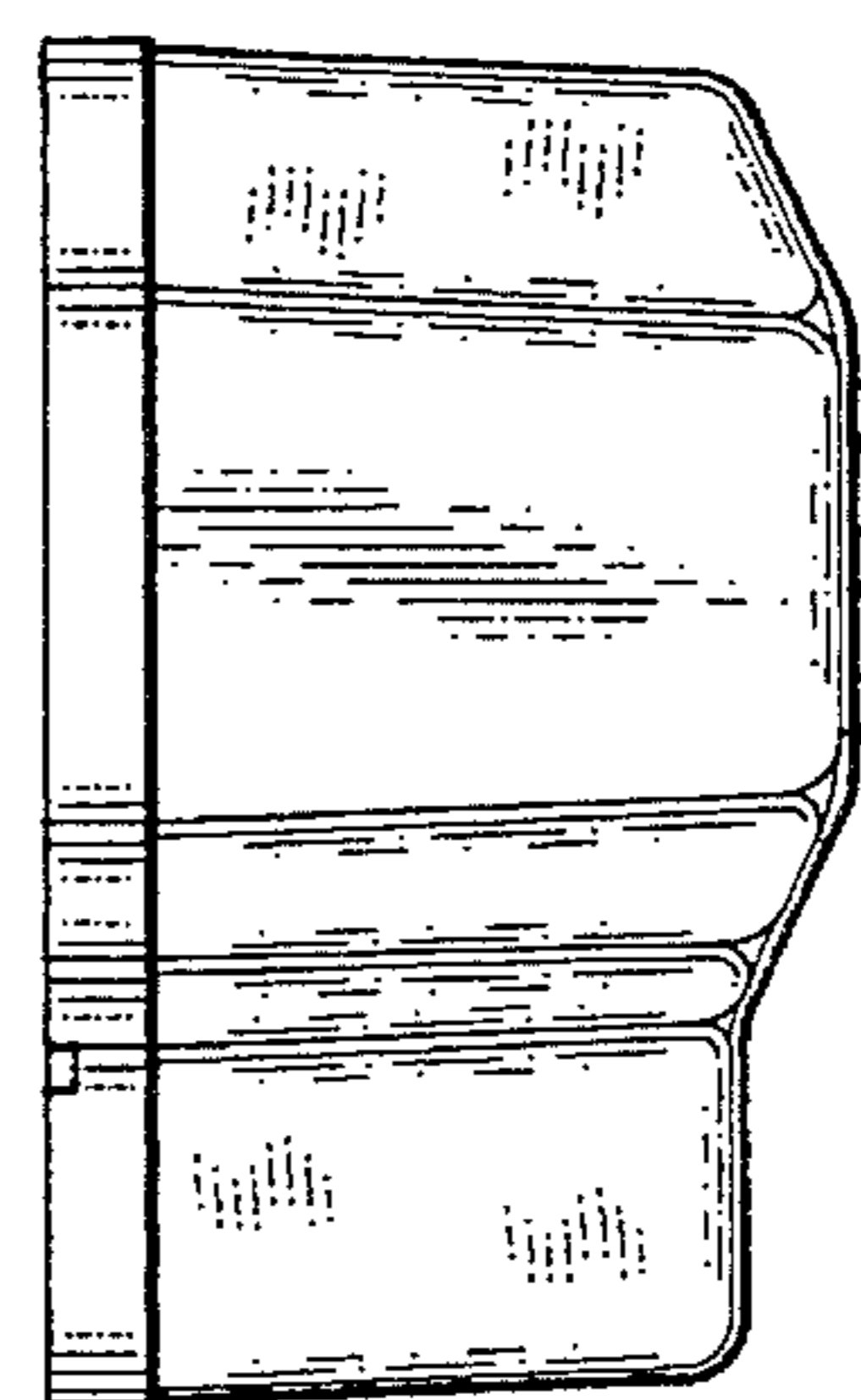

Fig. 16