



US00D362893S

United States Patent [19]

[11] Patent Number: **Des. 362,893**

Osborne

[45] Date of Patent: ****Oct. 3, 1995**

[54] **IN-LINE ROLLER SKATE FRAME**

5,374,072 12/1994 Landers 280/11.27

[75] Inventor: **Samuel Osborne**, Burlington, Vt.

Primary Examiner—Theodore M. Shooman

Assistant Examiner—R. Barkai

[73] Assignee: **Karhu U.S.A., Inc.**, South Burlington, Vt.

Attorney, Agent, or Firm—Bachman & LaPointe

[**] Term: **14 Years**

[57] **CLAIM**

The ornamental design for an in-line roller skate frame, as shown and described.

[21] Appl. No.: **23,165**

DESCRIPTION

[22] Filed: **May 19, 1994**

[52] U.S. Cl. **D21/226**

[58] Field of Search D21/191, 198, D21/224-227, 230; 280/11.2, 11.19, 11.22, 11.27, 11.23, 809, 816

FIG. 1 is a right side elevational view of an in-line roller skate frame showing my new design, the broken line showing of the boot and wheels is for illustrative purposes only and form no part of the claimed design;

FIG. 2 is a left side elevational view thereof, the broken line showing of the boot is for illustrative purposes only and forms no part of the claimed design;

FIG. 3 is a left side elevational view thereof;

FIG. 4 is a top plan view thereof;

FIG. 5 is a rear elevational view thereof;

FIG. 6 is a front elevational view thereof;

FIG. 7 is a perspective view thereof;

FIG. 8 is a right side elevational view of an in-line roller skate frame showing a second embodiment of my new design;

FIG. 9 is a bottom plan view thereof;

FIG. 10 is a left side elevational view thereof;

FIG. 11 is a top plan view thereof;

FIG. 12 is a rear elevational view thereof;

FIG. 13 is a front elevational view thereof; and,

FIG. 14 is a perspective view thereof.

[56] **References Cited**

U.S. PATENT DOCUMENTS

D. 301,908	6/1989	Olson et al. .	
D. 321,393	11/1991	Olson et al. .	
D. 323,540	1/1992	Graham .	
D. 325,417	4/1992	McNamara et al. .	
D. 325,418	4/1992	McNamara .	
D. 334,607	4/1993	Soo	D21/226
D. 343,669	1/1994	Pratt	D21/226
D. 354,105	1/1995	Melbock et al.	D21/226
4,711,458	12/1987	Shim .	
5,046,746	9/1991	Gierveld .	
5,048,848	9/1991	Olsen et al.	280/11.27
5,129,663	1/1992	Soo .	
5,143,387	9/1992	Colla .	
5,148,848	9/1991	Olson et al. .	
5,193,827	3/1993	Olson .	
5,207,454	5/1993	Blankenburg et al. .	
5,314,199	5/1994	Olsen et al.	280/11.27

1 Claim, 4 Drawing Sheets

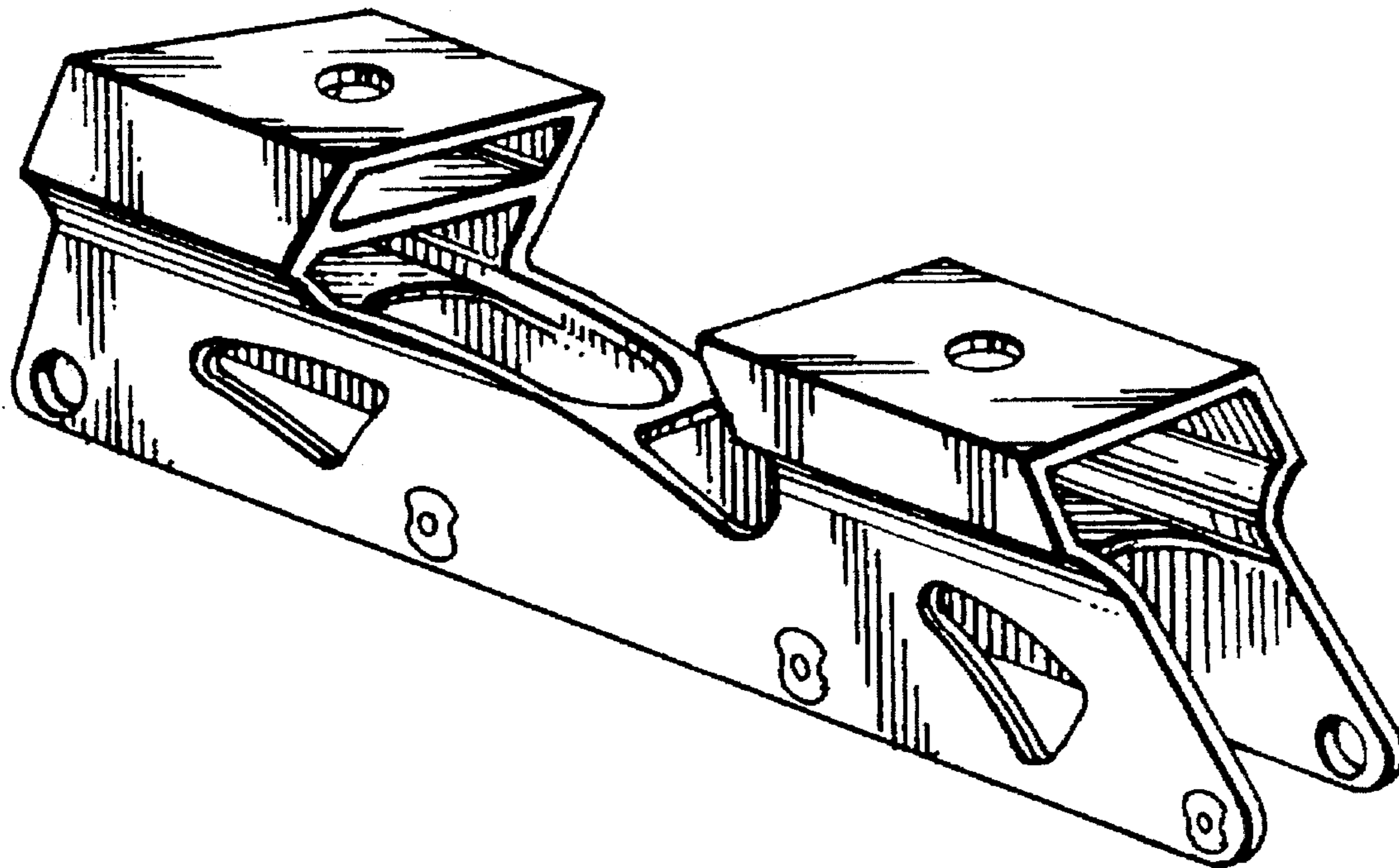

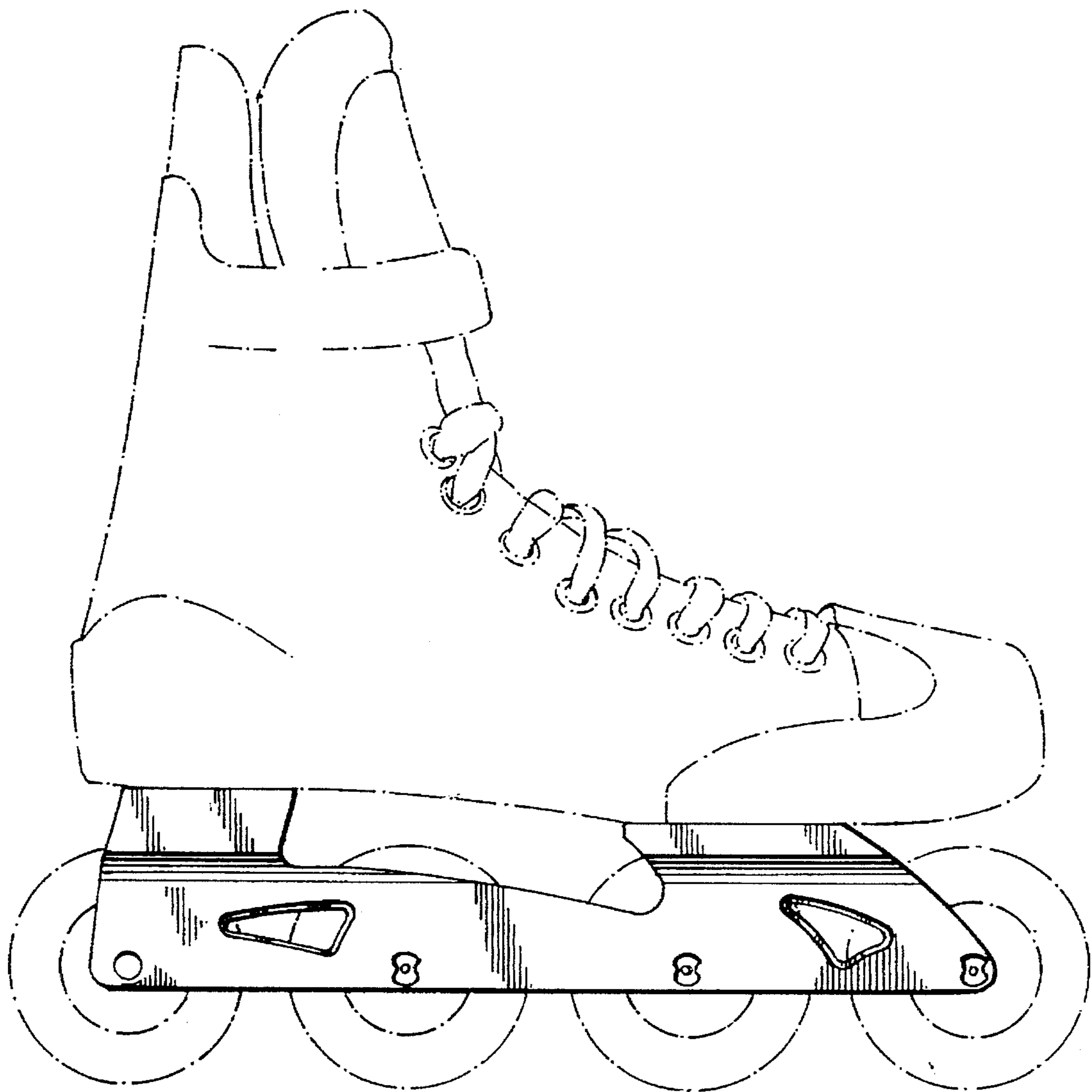

FIG. 1

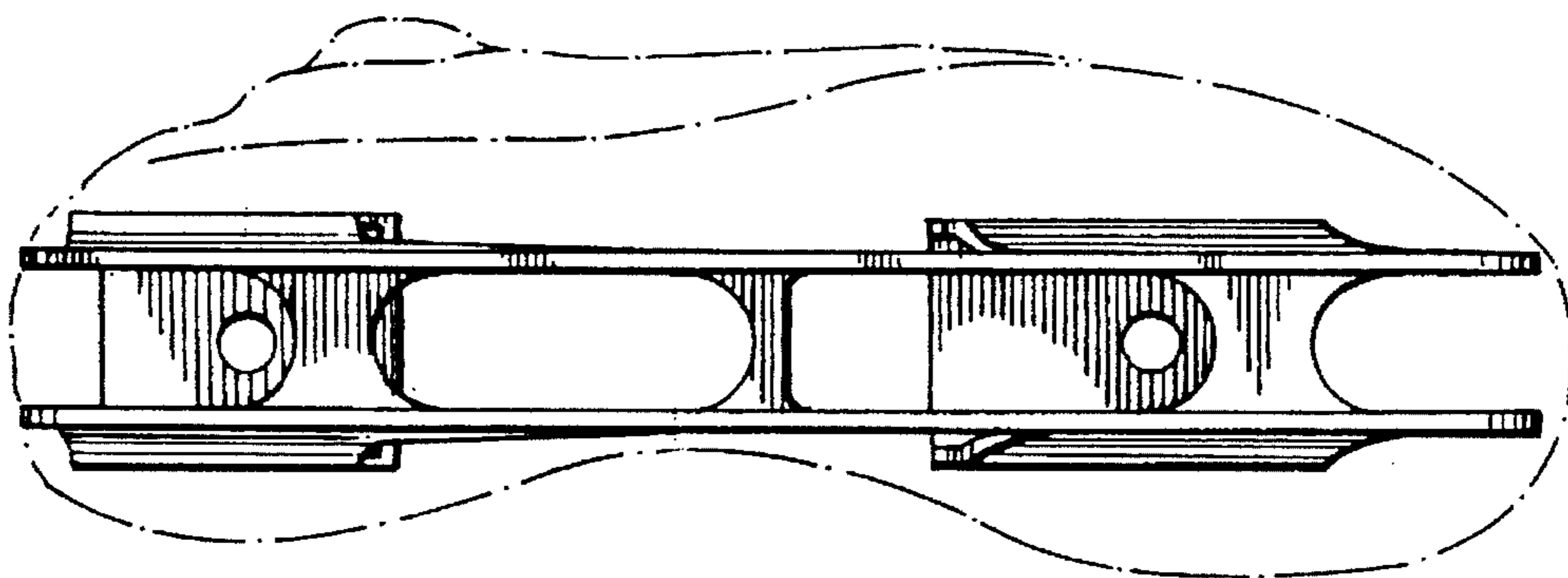

FIG. 2

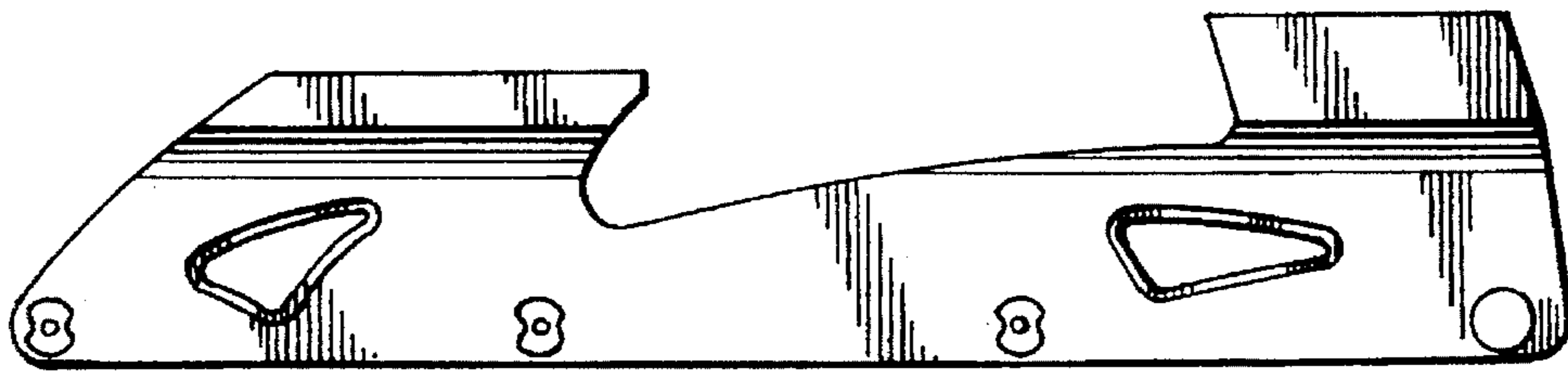

FIG. 3

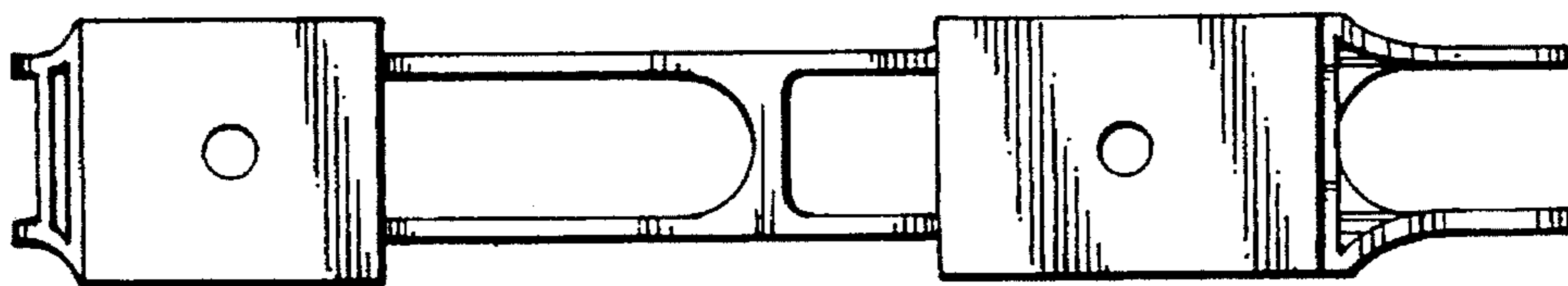

FIG. 4

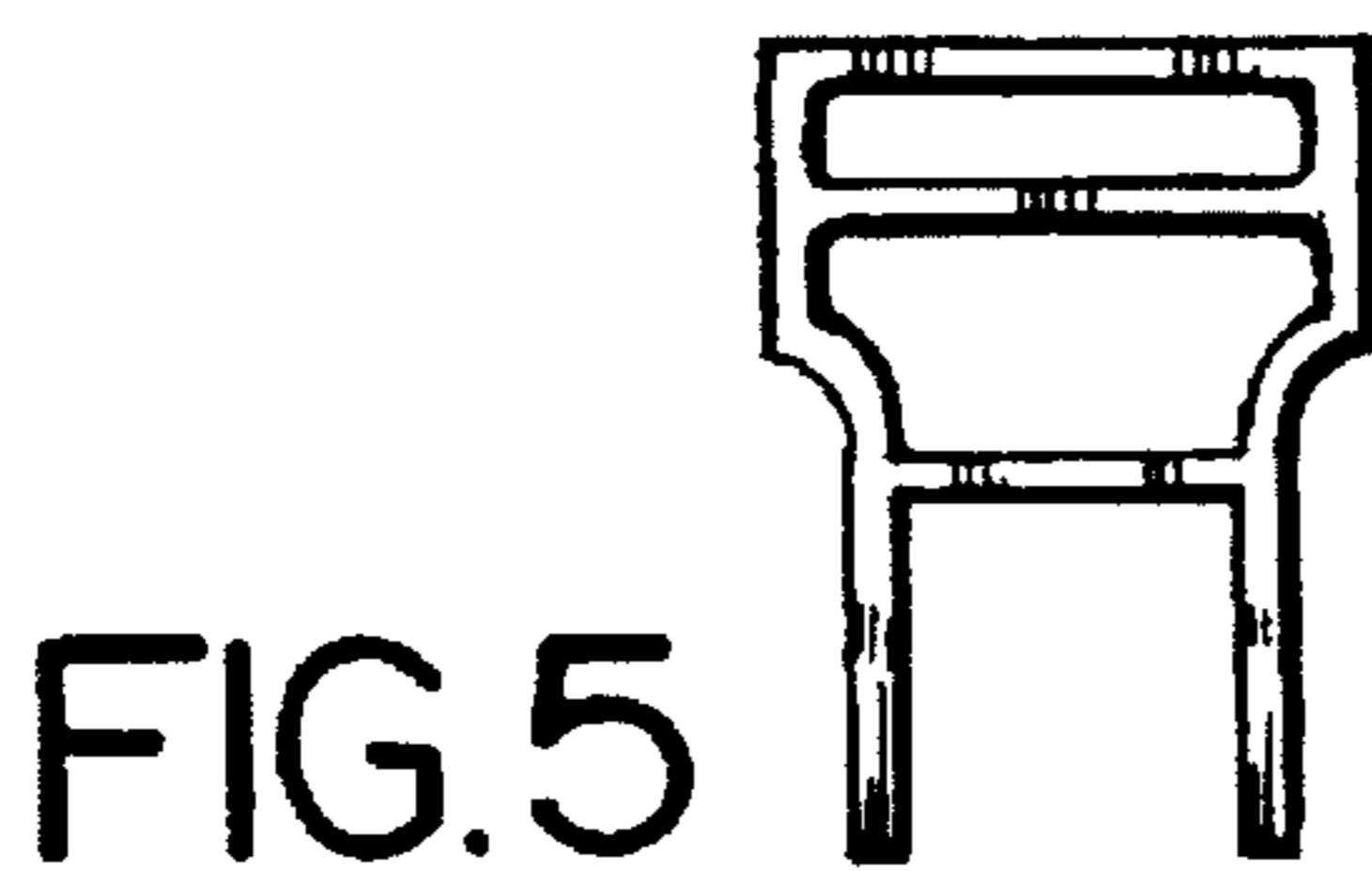

FIG. 5

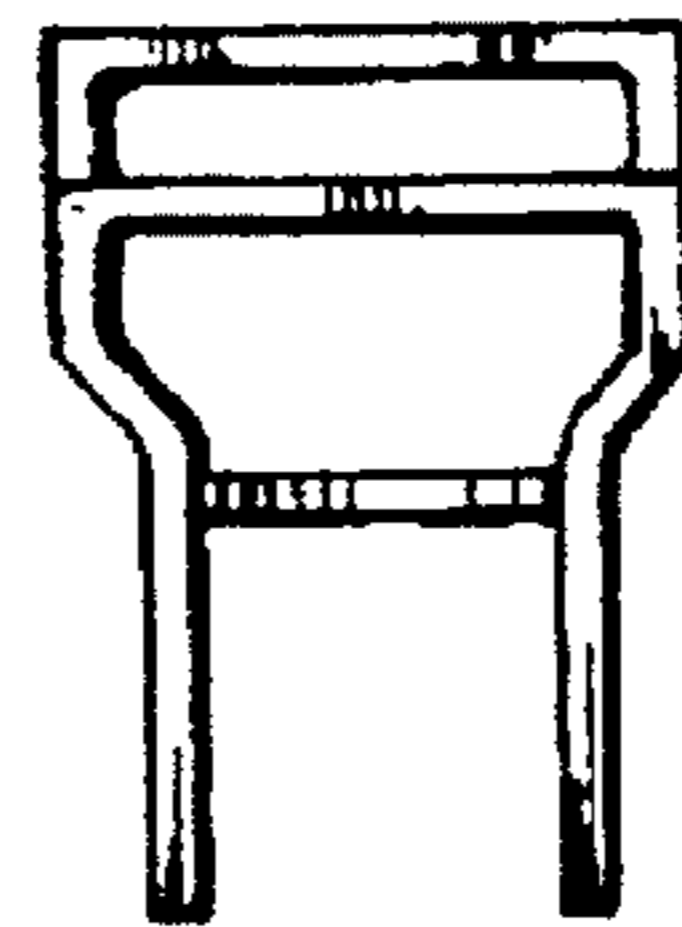

FIG. 6

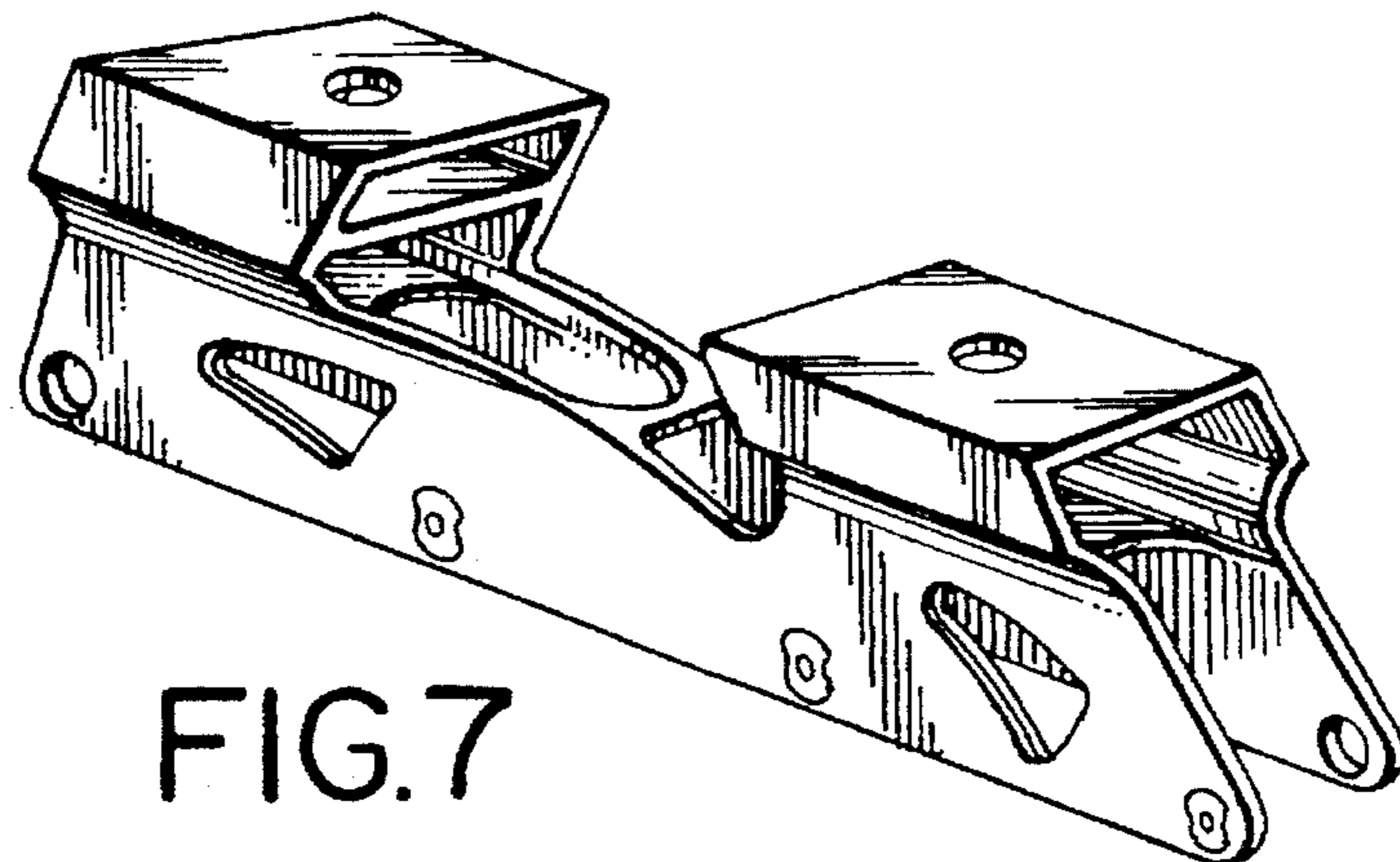

FIG. 7

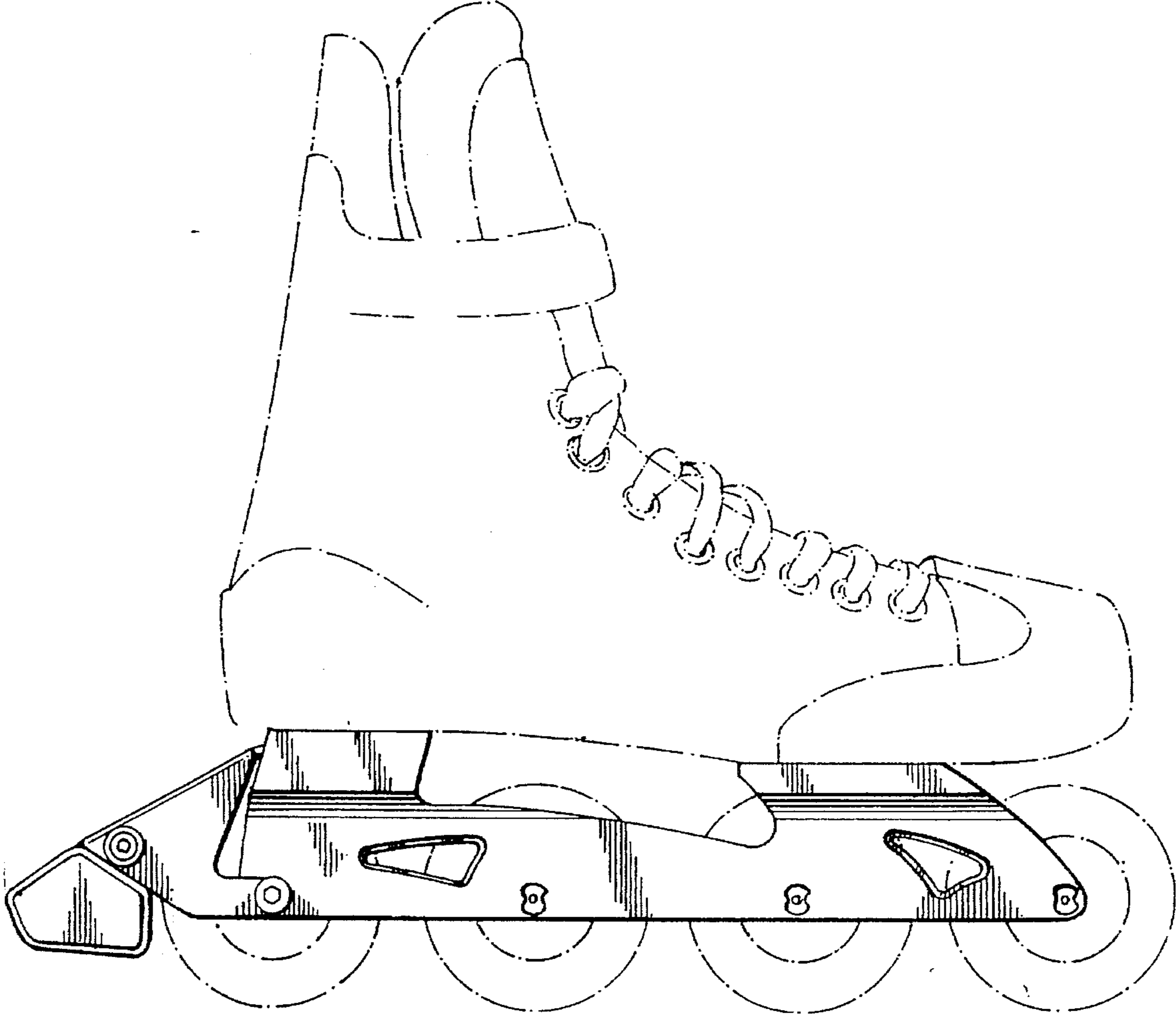

FIG. 8

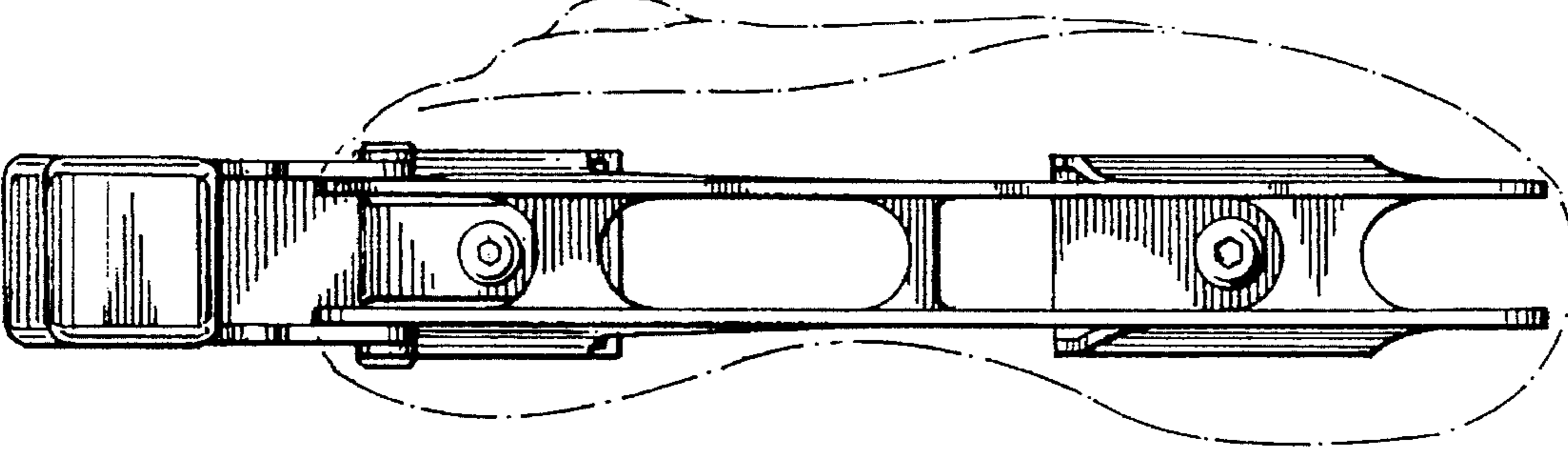

FIG. 9

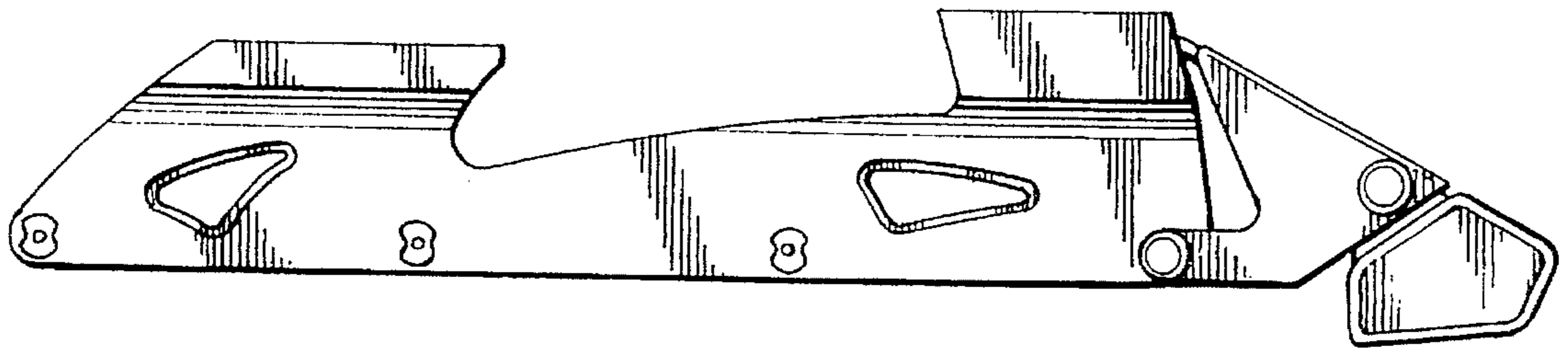

FIG. 10

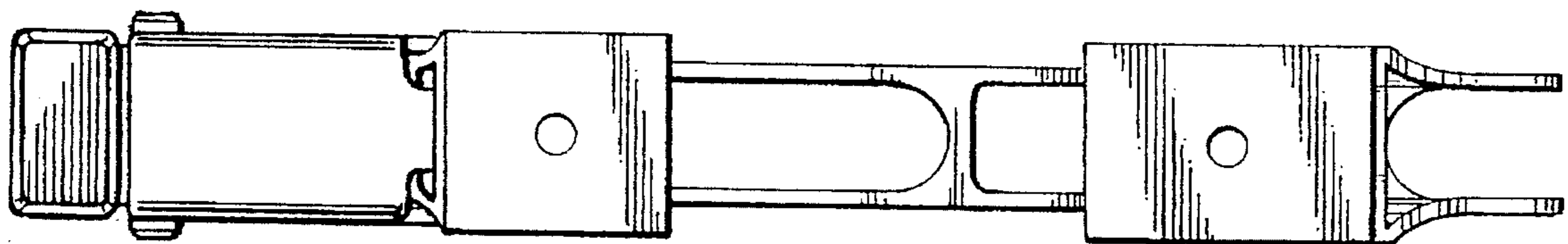

FIG. 11

FIG. 12

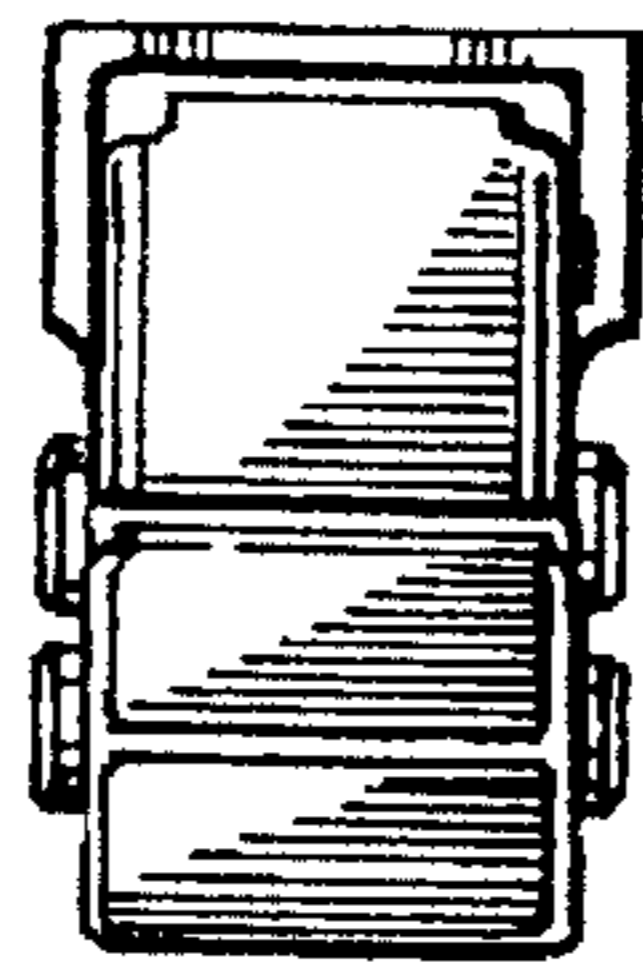

FIG. 13

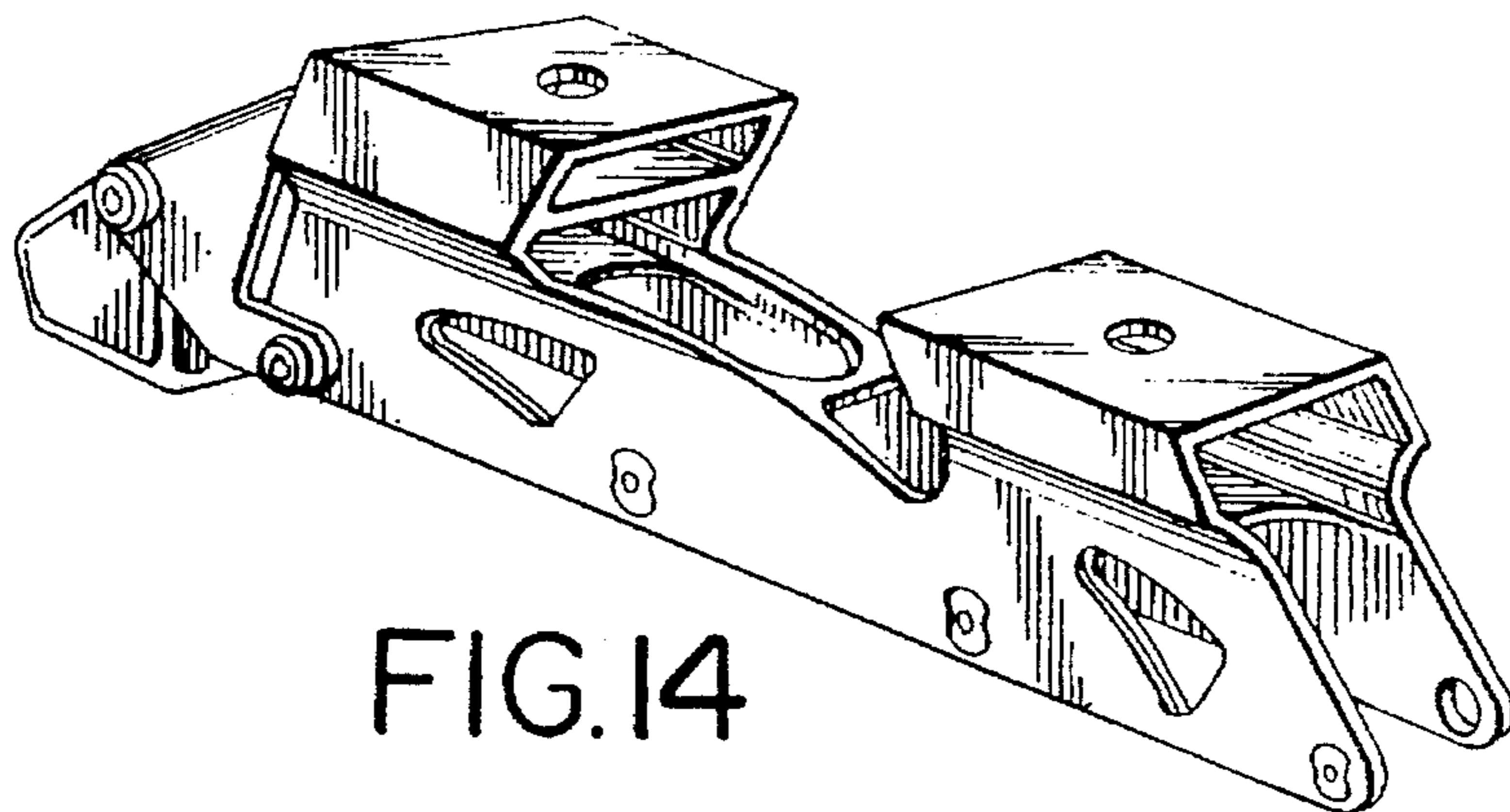
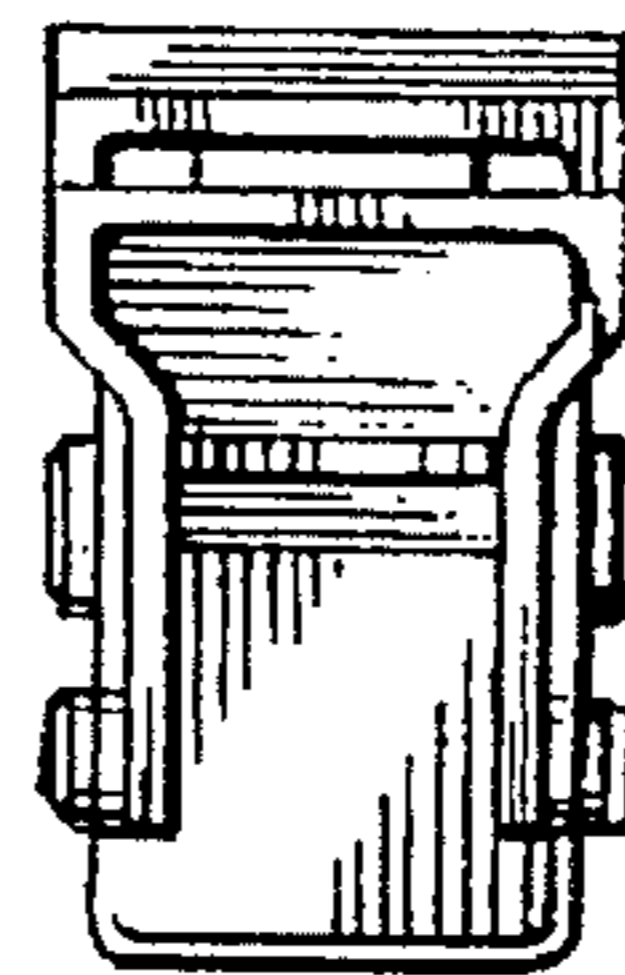

FIG. 14