



US00D362842S

United States Patent [19]

[11] Patent Number: **Des. 362,842**

Levine

[45] Date of Patent: ****Oct. 3, 1995**

[54] LATCH AND KNOB COMBINATION

4,000,382 12/1976 Kolb 200/336
4,406,933 9/1983 Boozer 200/336

[75] Inventor: **Mark Levine**, Plainview, N.J.

Primary Examiner—B. J. Bullock
Attorney, Agent, or Firm—Darby & Darby

[73] Assignee: **General Automotive Specialty Co., Inc.**, North Brunswick, N.J.

[57] CLAIM

[**] Term: **14 Years**

The ornamental design for a latch and knob combination, as shown and described.

[21] Appl. No.: **19,645**

DESCRIPTION

[22] Filed: **Mar. 8, 1994**

[52] U.S. Cl. **D13/174; D8/310**

FIG. 1 shows a perspective view of the latch and knob combination design of the present invention;

[58] Field of Search D8/307, 310; D13/158, D13/174; 200/318, 318.1, 318.2, 321, 322, 323, 324, 325, 327, 336

FIG. 2 shows a top view of the design of FIG. 1, the bottom view being a mirror image of FIG. 2;

FIG. 3 shows a right end view of the design of FIG. 1;

FIG. 4 shows a left end view of the design of FIG. 1;

FIG. 5 shows a left side view of the design of FIG. 1; and,

FIG. 6 shows a right side view of the design of FIG. 1.

[56] References Cited

U.S. PATENT DOCUMENTS

3,345,489 10/1967 Kemnitz 200/318.2
3,550,472 12/1970 Dummer 200/318.1
3,686,601 8/1972 Kaczmarek et al. 200/325.

1 Claim, 2 Drawing Sheets

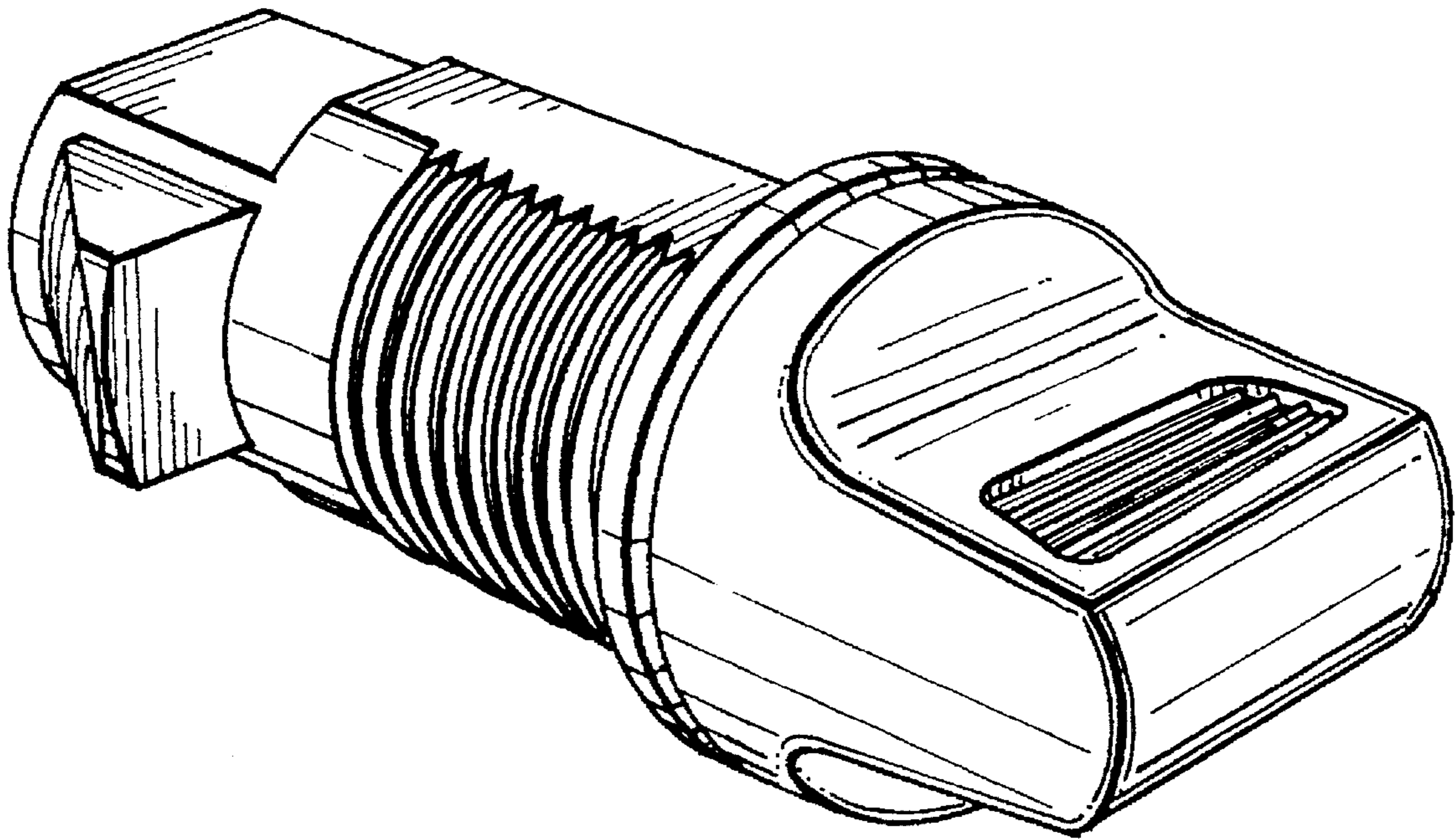

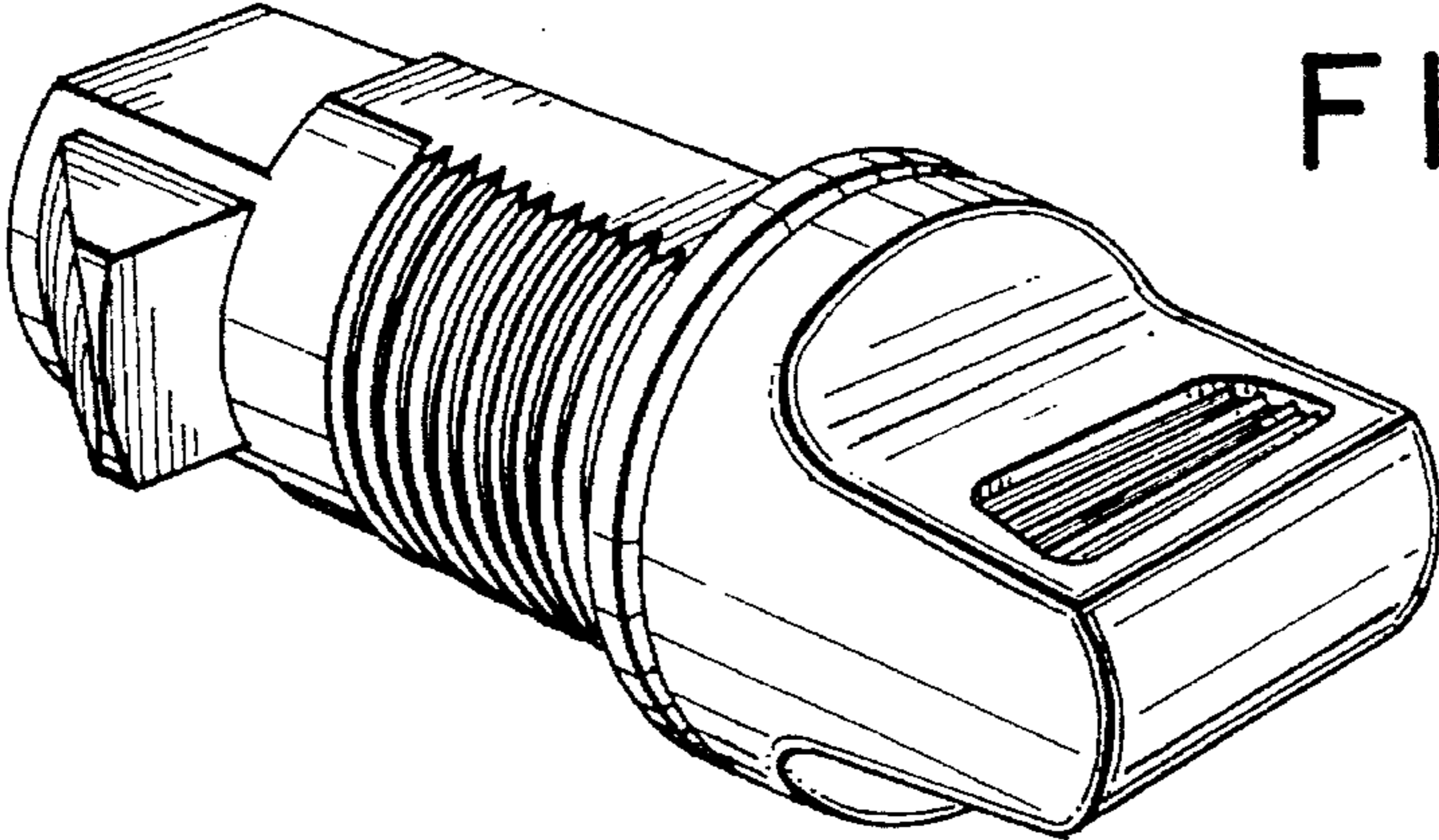

FIG. 1

FIG. 2

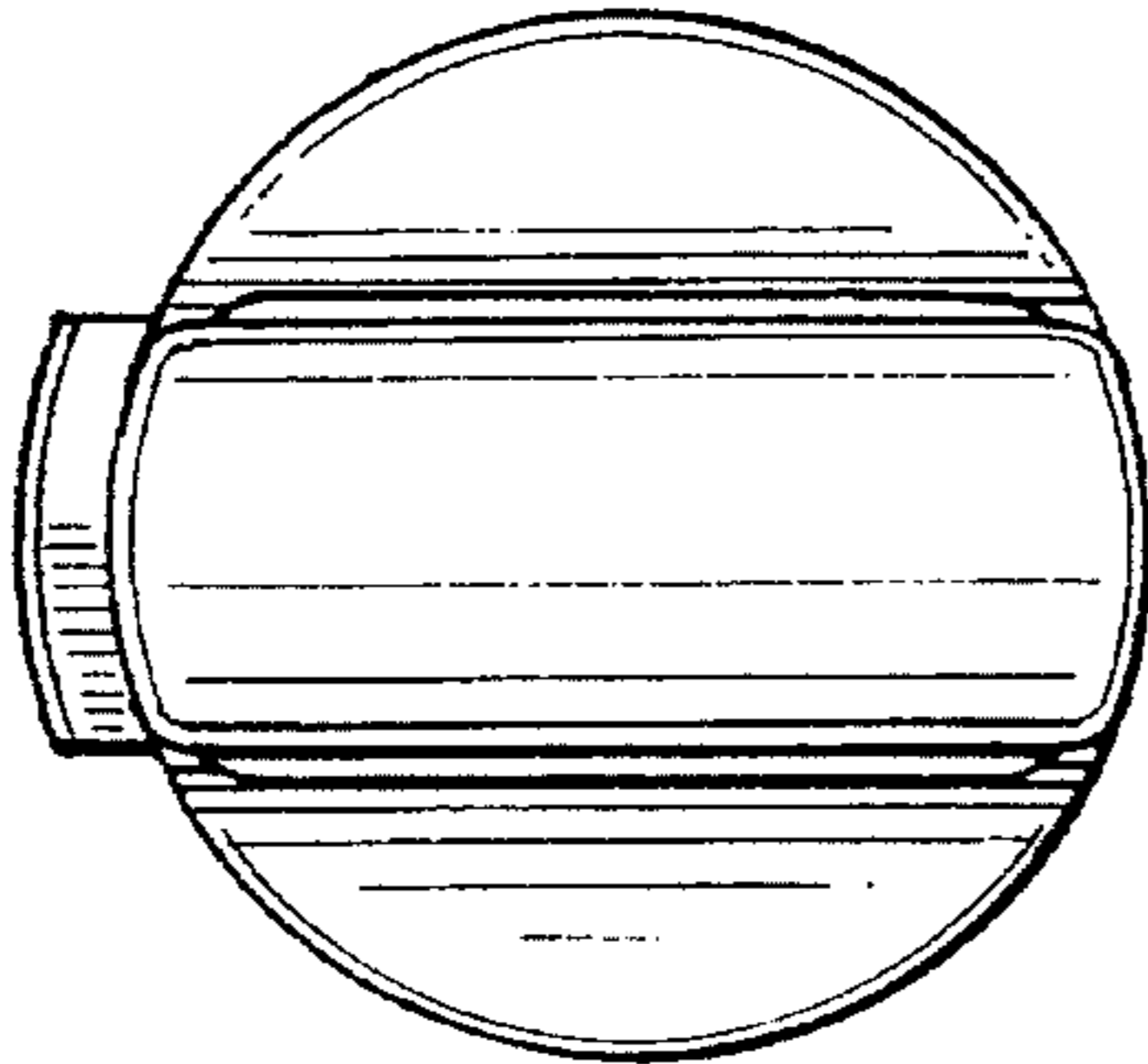
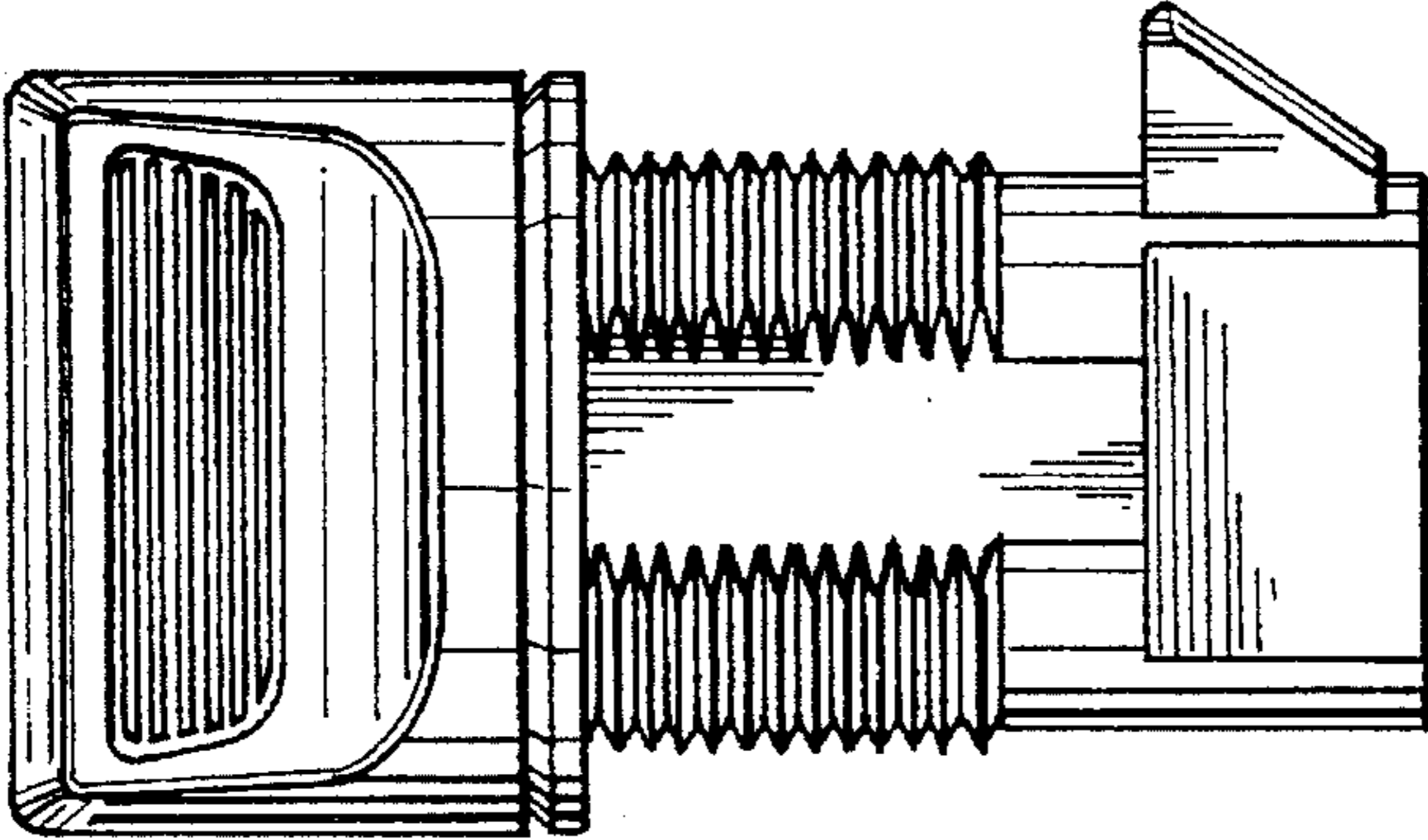

FIG. 3

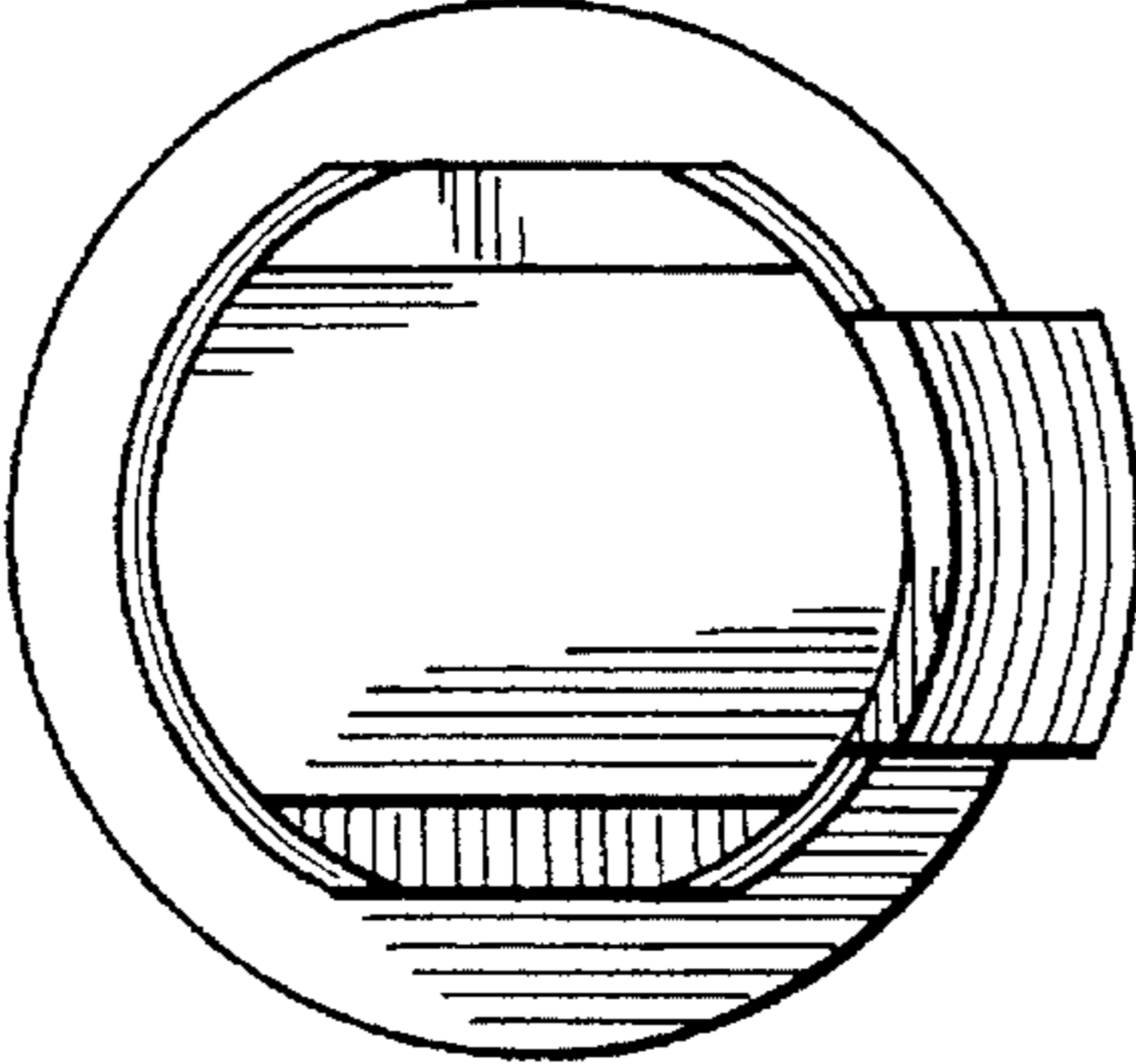

FIG. 4

FIG. 5

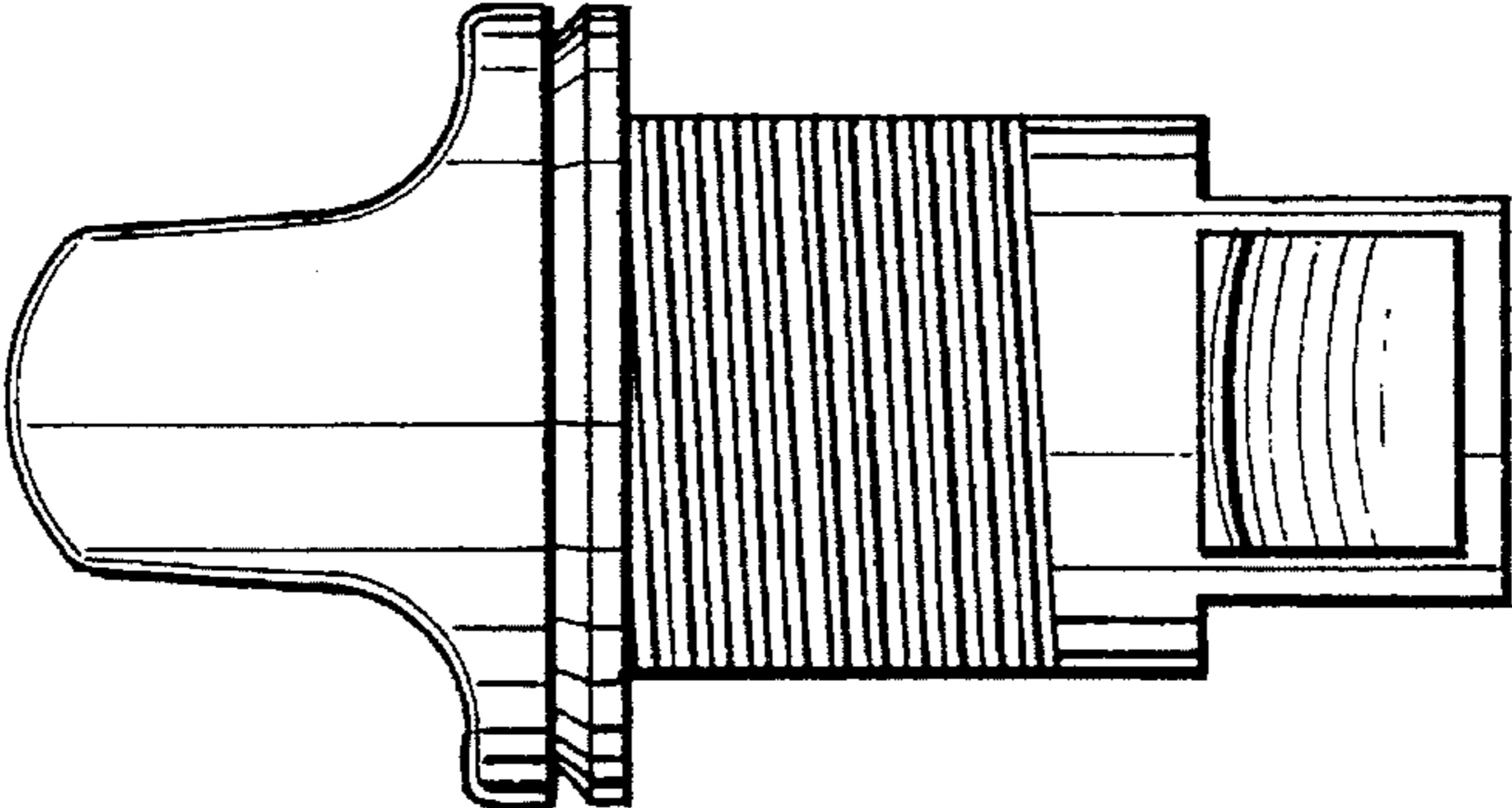

FIG. 6

