



US00D362821S

# United States Patent [19]

[11] Patent Number: **Des. 362,821**

Marchessault

[45] Date of Patent: **\*\*Oct. 3, 1995**

[54] EARRING

[76] Inventor: **Timothy R. Marchessault**, P.O. Box 4474, Aspen, Colo. 81612

[\*\*] Term: **14 Years**

[21] Appl. No.: **27,662**

[22] Filed: **Aug. 26, 1994**

[52] U.S. Cl. .... **D11/41**

[58] Field of Search ..... **D11/1, 2, 40-78; 63/1.1, 2, 12-14.8**

[56] **References Cited**

**U.S. PATENT DOCUMENTS**

- D. 326,066 5/1992 Sprague ..... D11/41
- D. 356,052 3/1995 Andrau ..... D11/40

**OTHER PUBLICATIONS**

Advertisement on Acrylic Stone Enhancers. Date unknown.

*Primary Examiner*—Ralf T. Seifert

*Attorney, Agent, or Firm*—Gary M. Polumbus; Holland & Hart

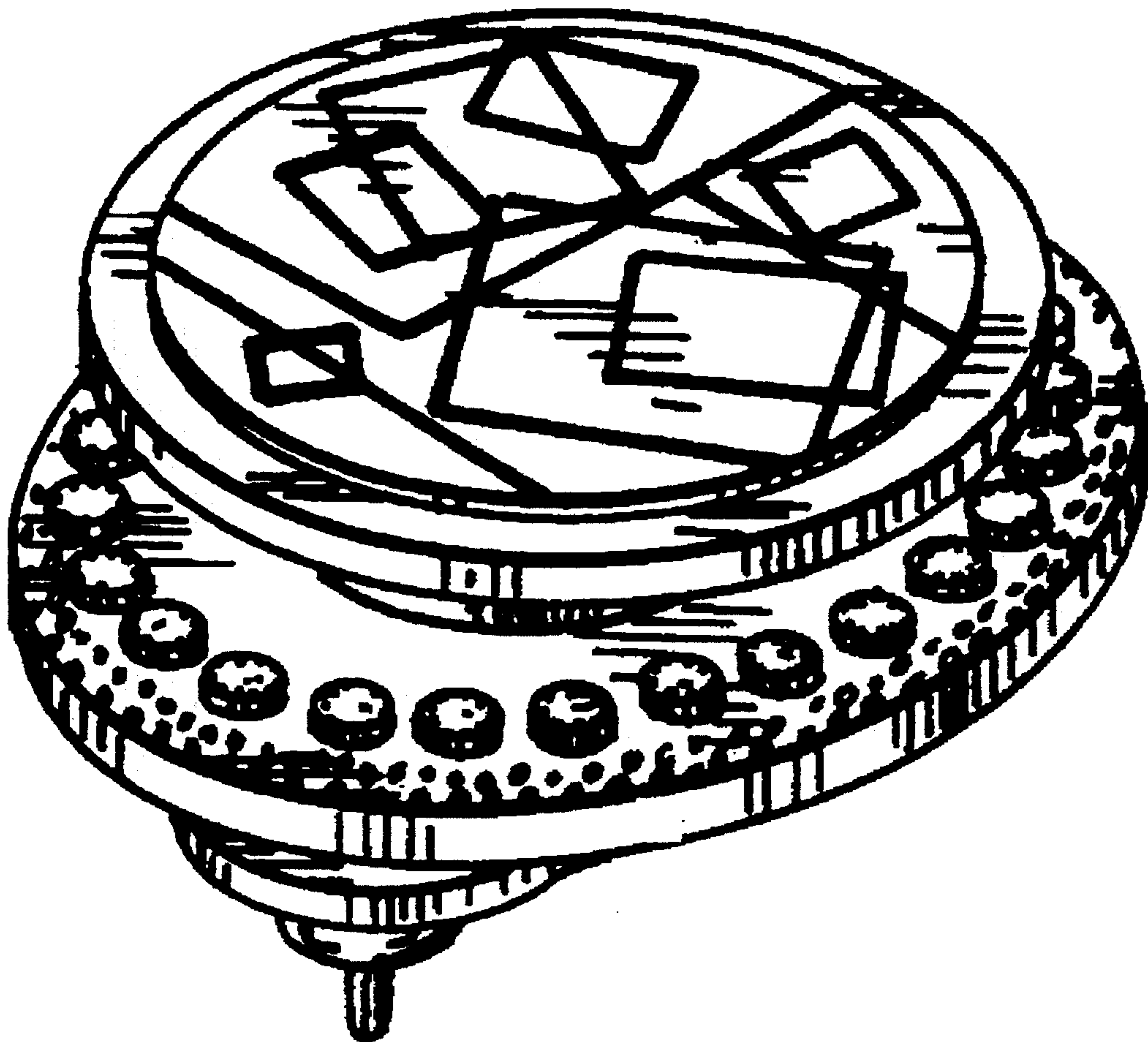
[57] **CLAIM**

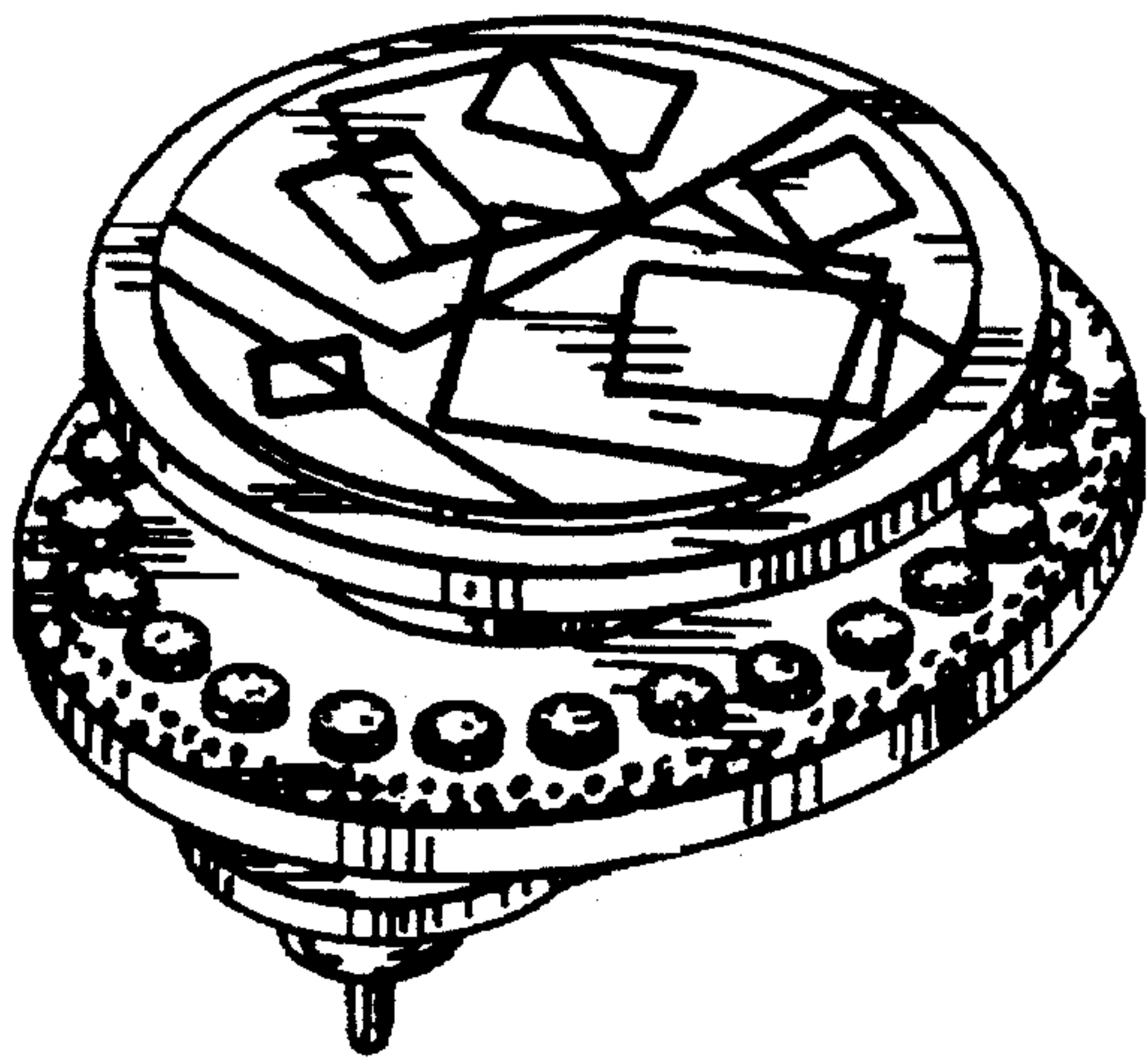
The ornamental design for an earring, as shown.

**DESCRIPTION**

FIG. 1 is an isometric view of the earring;  
 FIG. 2 is a top plan view thereof;  
 FIG. 3 is a right side elevation view thereof;  
 FIG. 4 is a top view thereof;  
 FIG. 5 is a rear view thereof; and,  
 FIG. 6 is an exploded isometric view thereof.

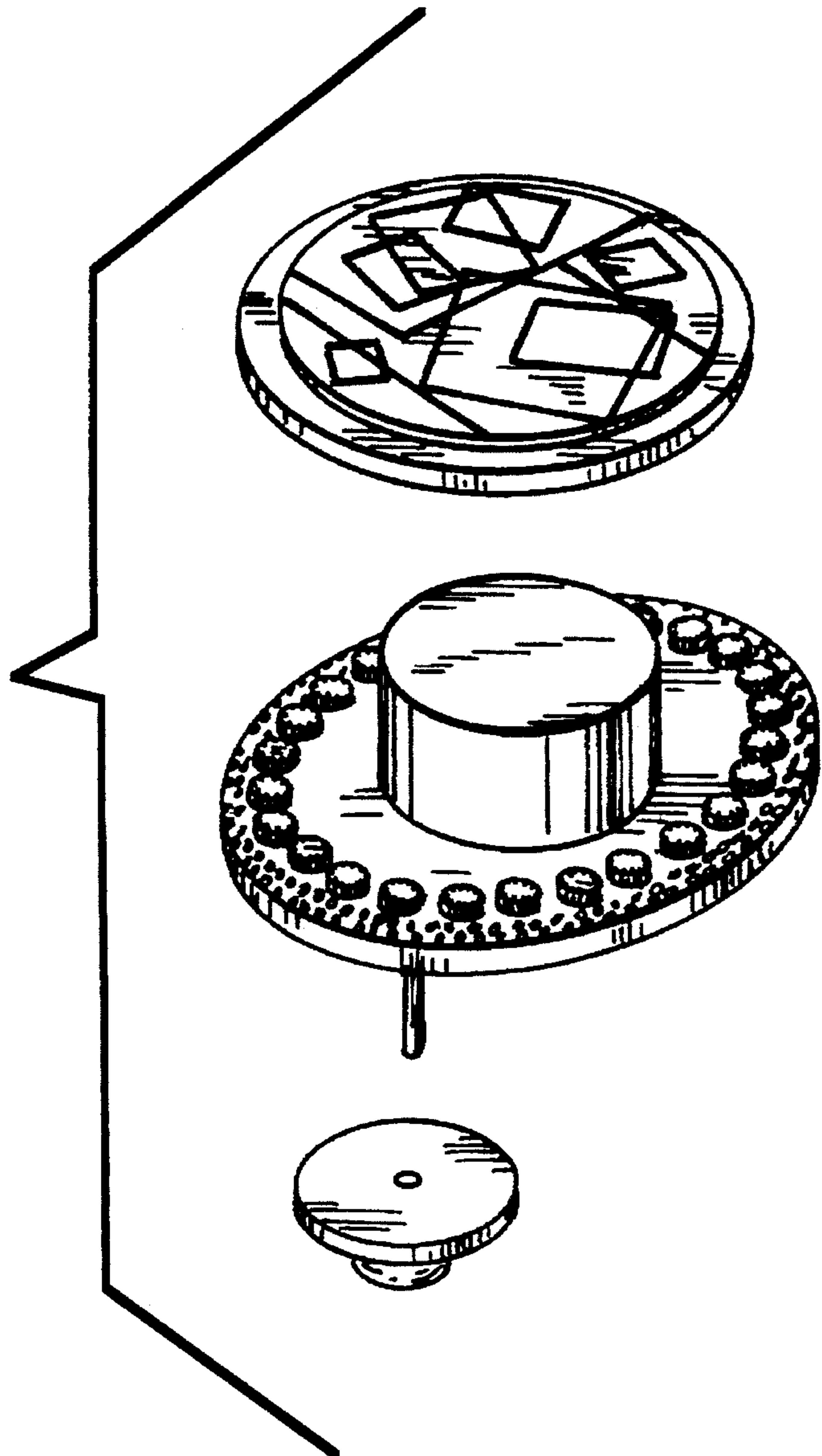
**1 Claim, 2 Drawing Sheets**

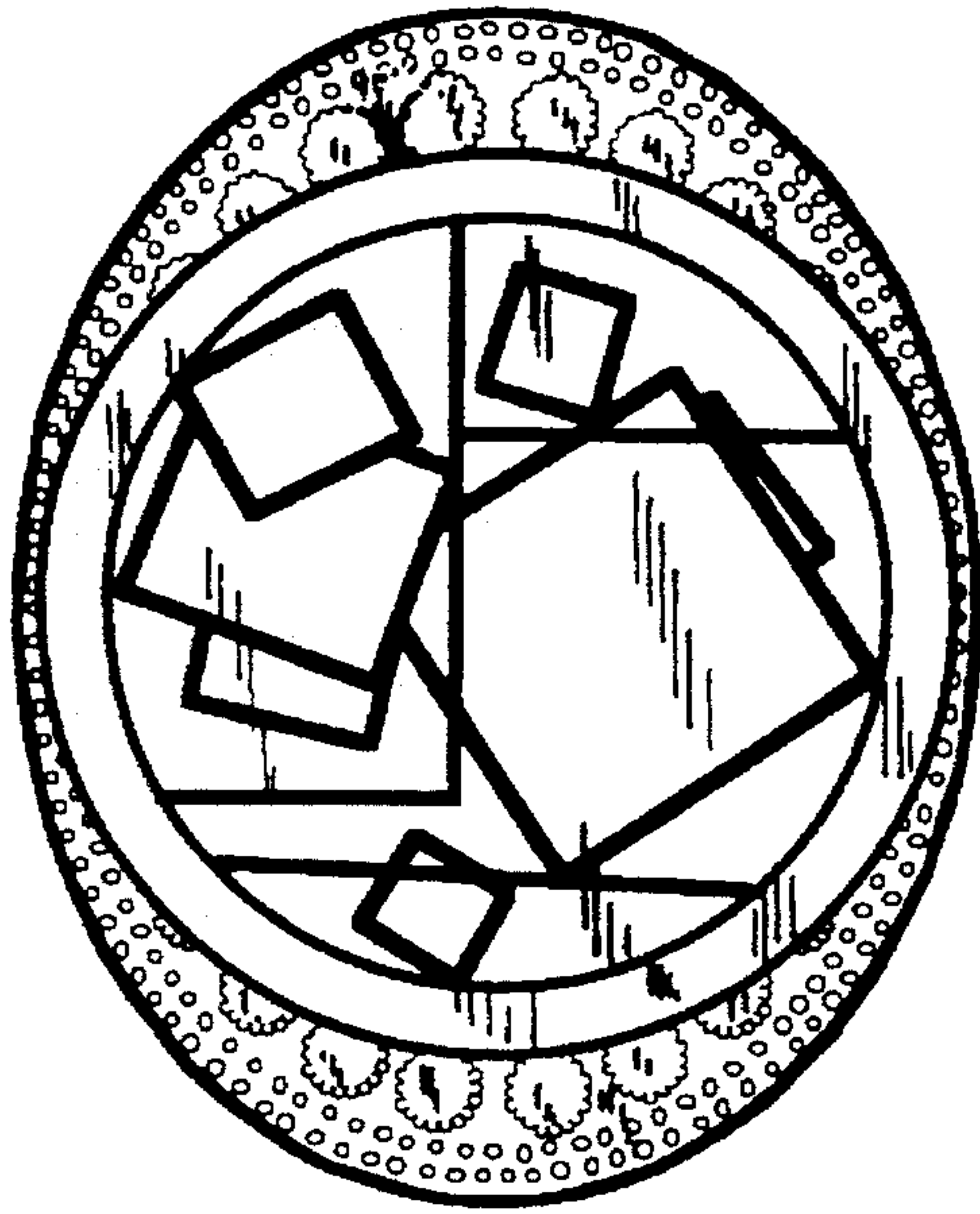




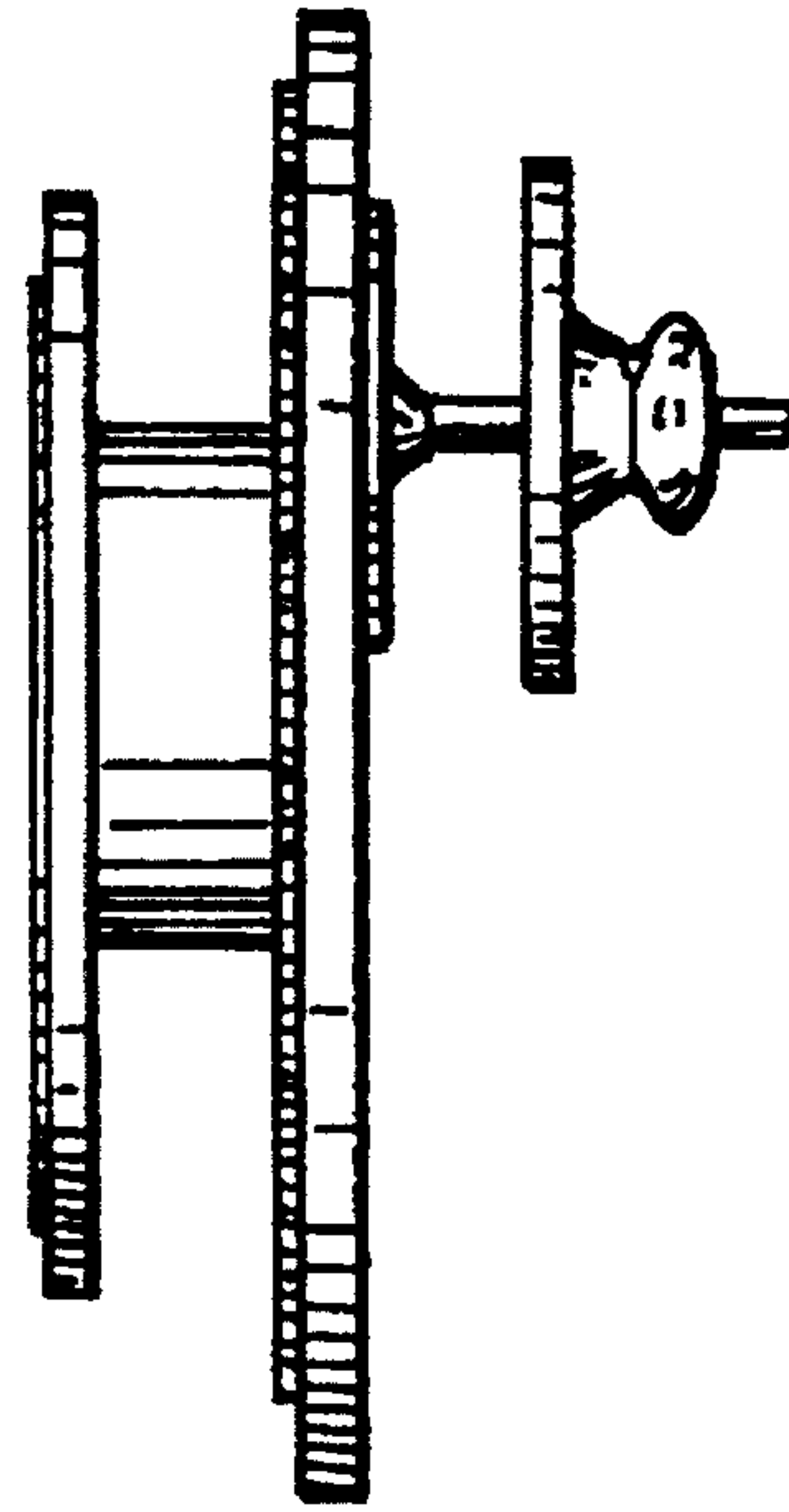
**Fig. 1**

**Fig. 6**

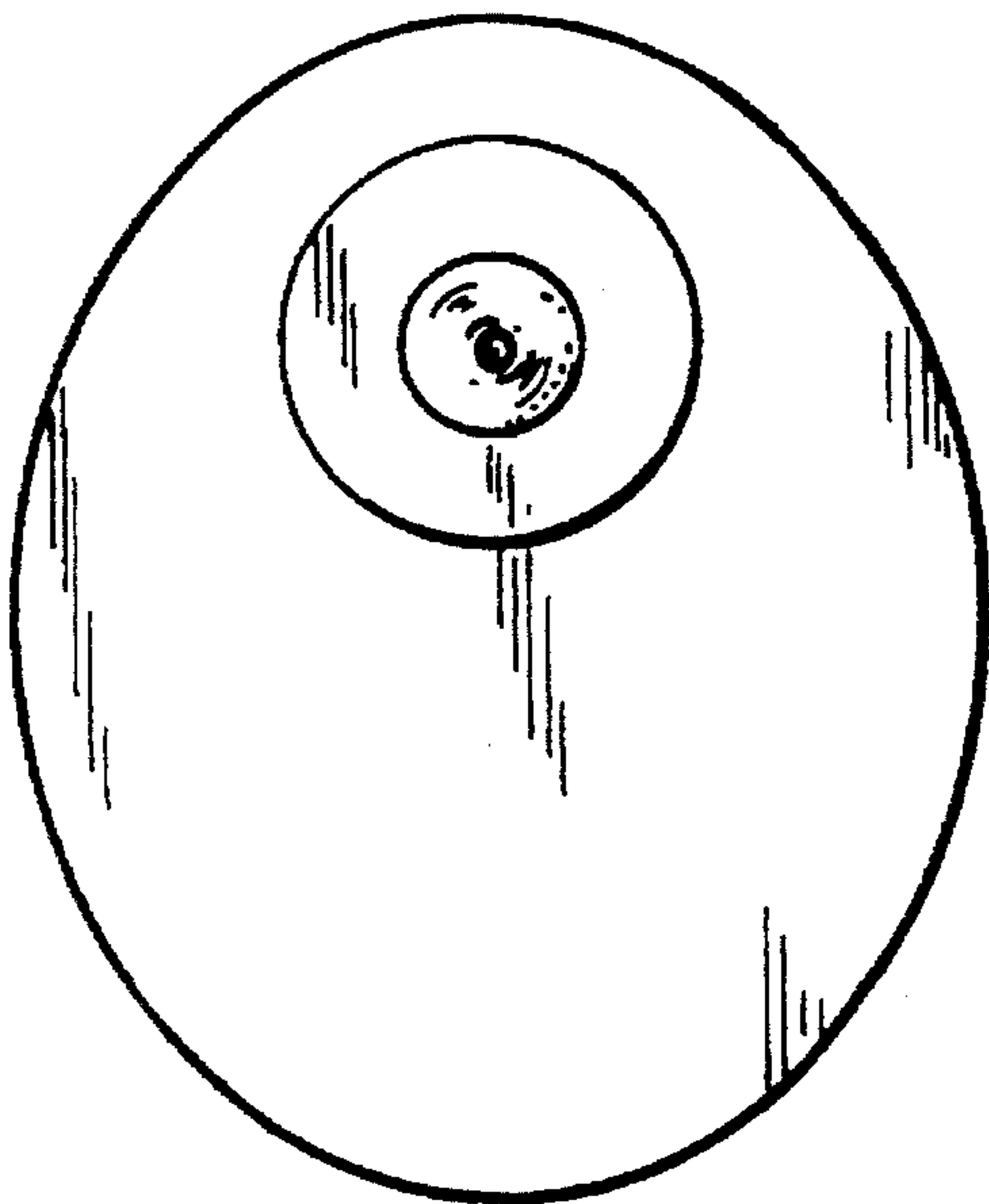




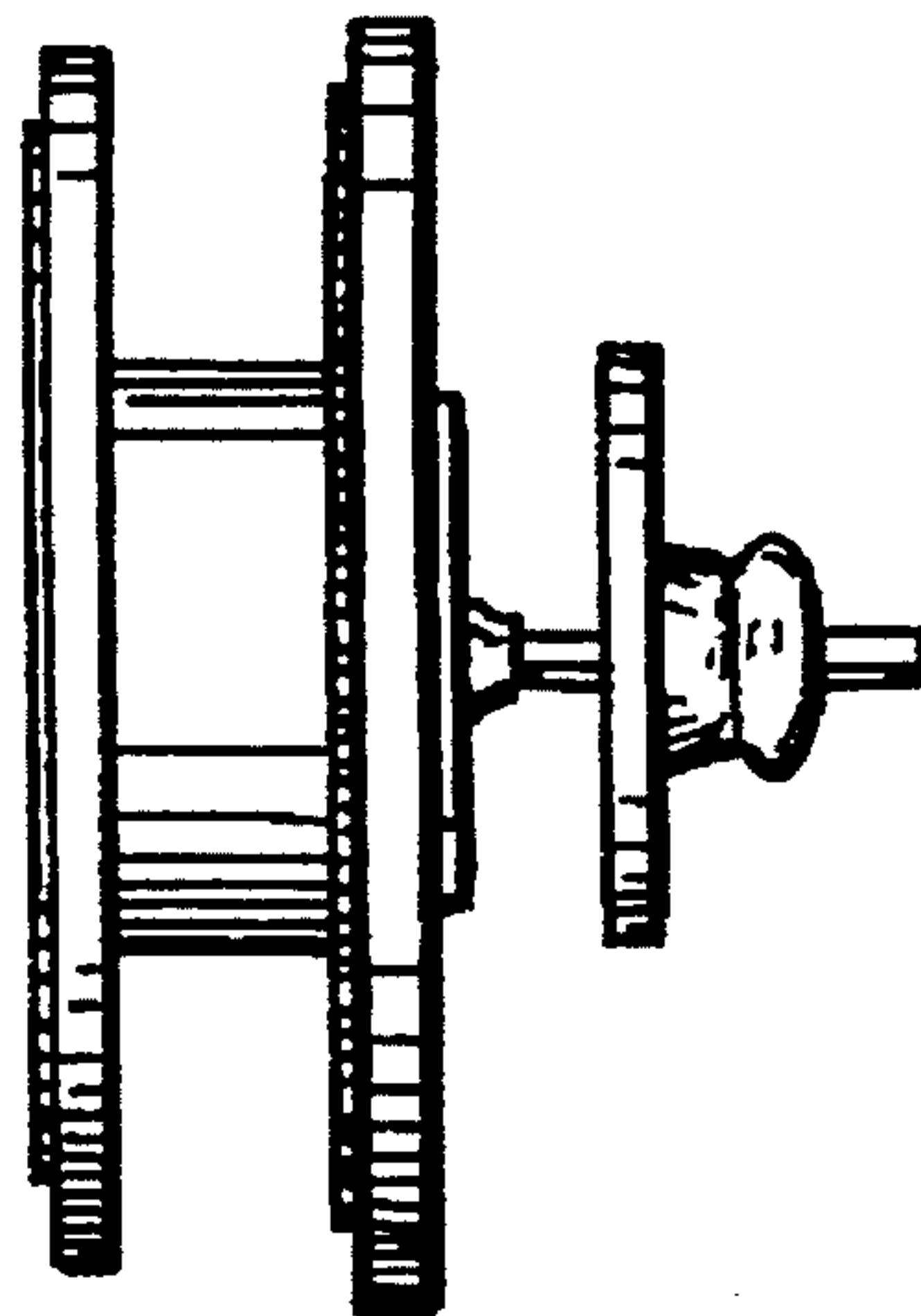
**Fig. 2**



**Fig. 3**



**Fig. 5**



**Fig. 4**