



US00D362736S

# United States Patent [19]

[11] Patent Number: **Des. 362,736**

**Leather**

[45] Date of Patent: **\*\*Sep. 26, 1995**

## [54] BODY MOUNTED LIGHT

[76] Inventor: **Terence H. Leather**, White Farm Cottage, Dreemskerry, Moughold, Isle of Man

[\*\*] Term: **14 Years**

[21] Appl. No.: **14,022**

[22] Filed: **Oct. 12, 1993**

[52] U.S. Cl. .... **D26/39; D10/114**

[58] Field of Search ..... **D26/37-50; 362/157, 362/158, 183, 184, 187-191, 196-200, 103, 107, 108; D10/114**

## [56] References Cited

### U.S. PATENT DOCUMENTS

4,788,631 11/1988 Fuller ..... 362/103  
5,193,896 3/1993 Oberlander ..... 362/200 X

Primary Examiner—Susan J. Lucas  
Attorney, Agent, or Firm—Richard E. Jenkins

## [57] CLAIM

The ornamental design for a body mounted light, as shown and described.

## DESCRIPTION

FIG. 1 is a side elevation view of the article comprising the lighting device;  
FIG. 2 is a top plan view of the article comprising the lighting device;  
FIG. 3 is a first end elevation view of the article comprising the lighting device;  
FIG. 4 is a second end elevation view of the article comprising the lighting device;  
FIG. 5 is a perspective view of the article comprising the lighting device; and,  
FIG. 6 is a bottom perspective view of the article comprising the lighting device. The strap is fragmentarily shown in FIGS. 2, 3, and 4 for convenience of illustration, The strap is fragmentarily shown in FIGS. 2, 3, and 4 for convenience of illustration.

**1 Claim, 2 Drawing Sheets**

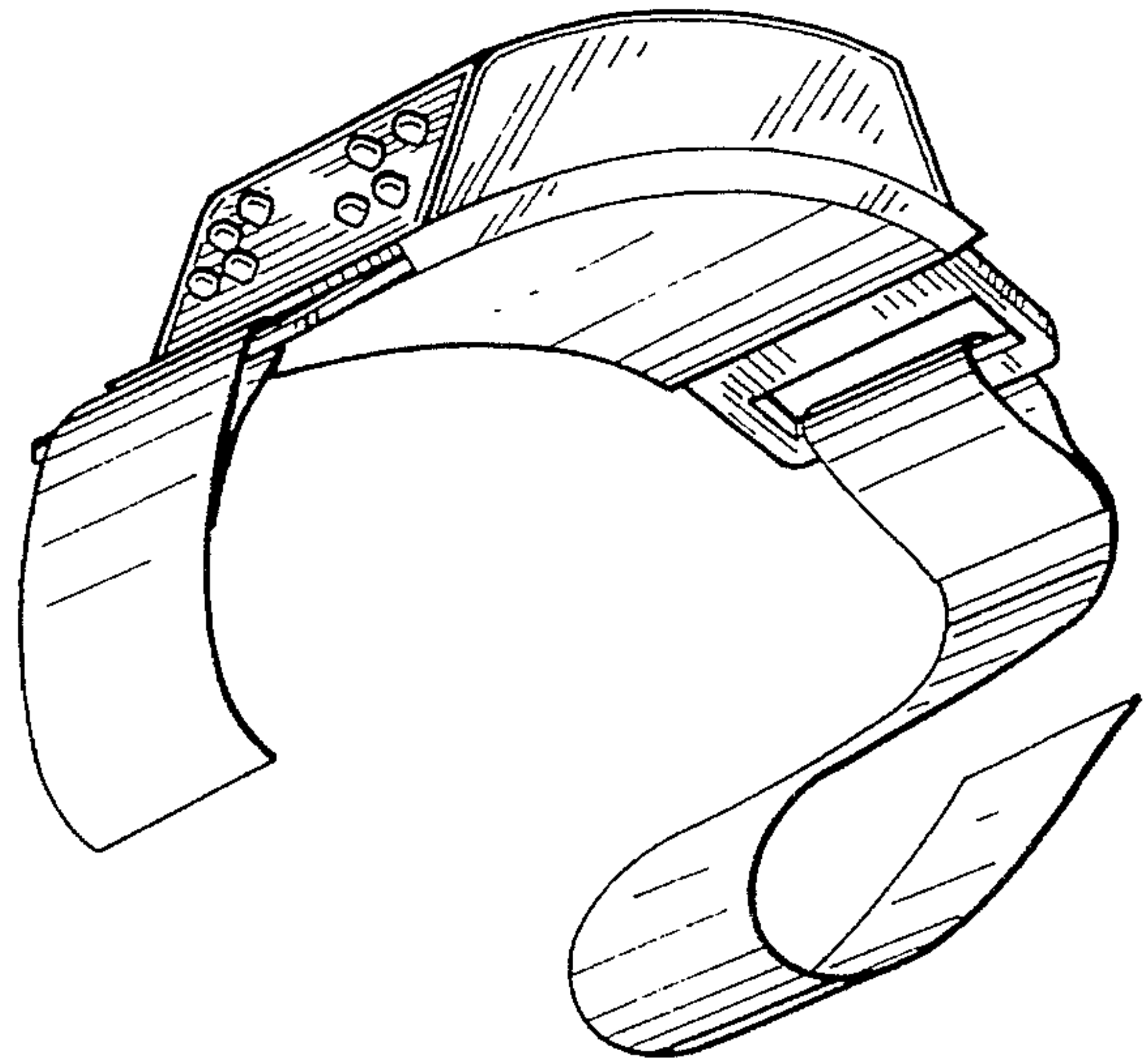
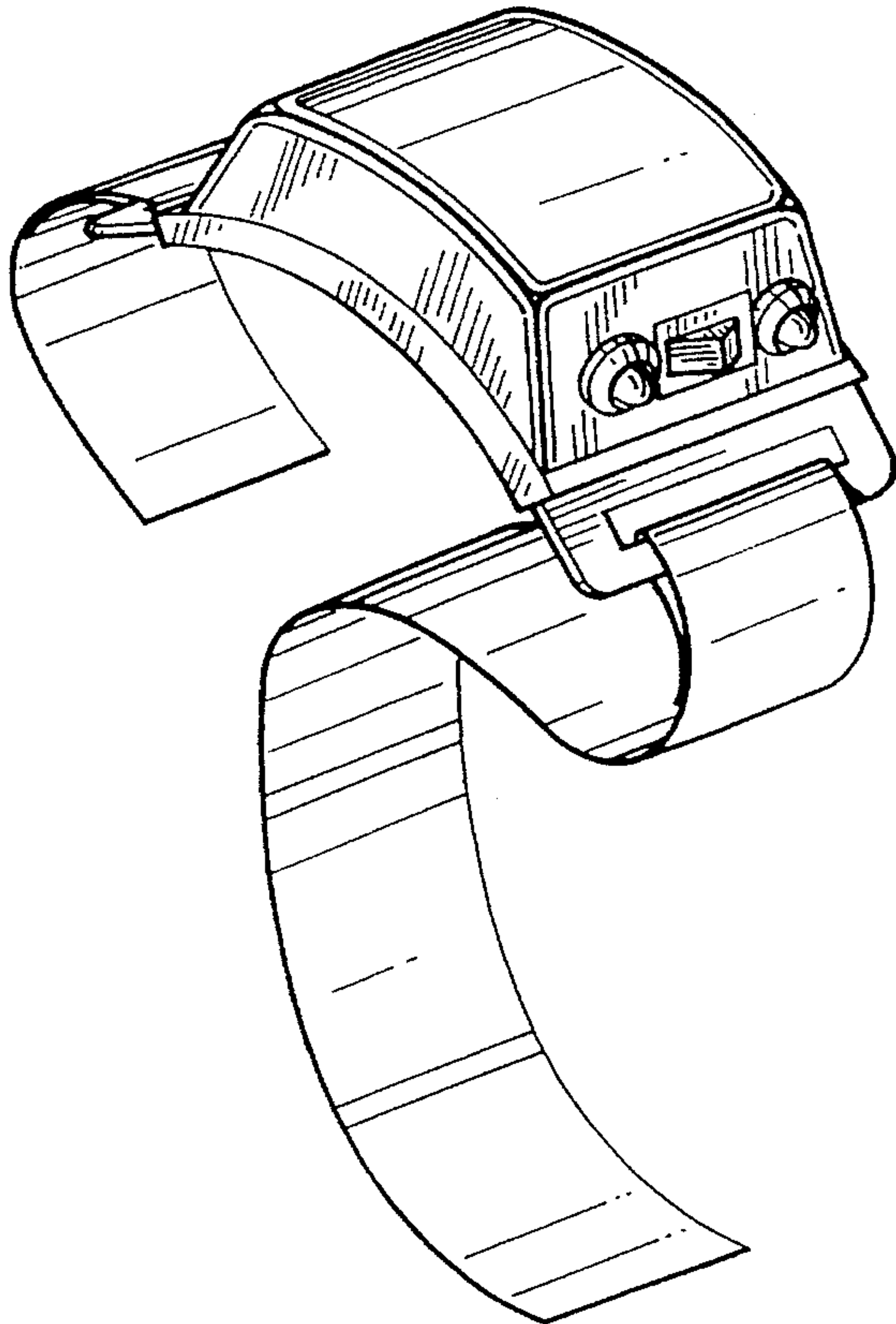

Fig. 1

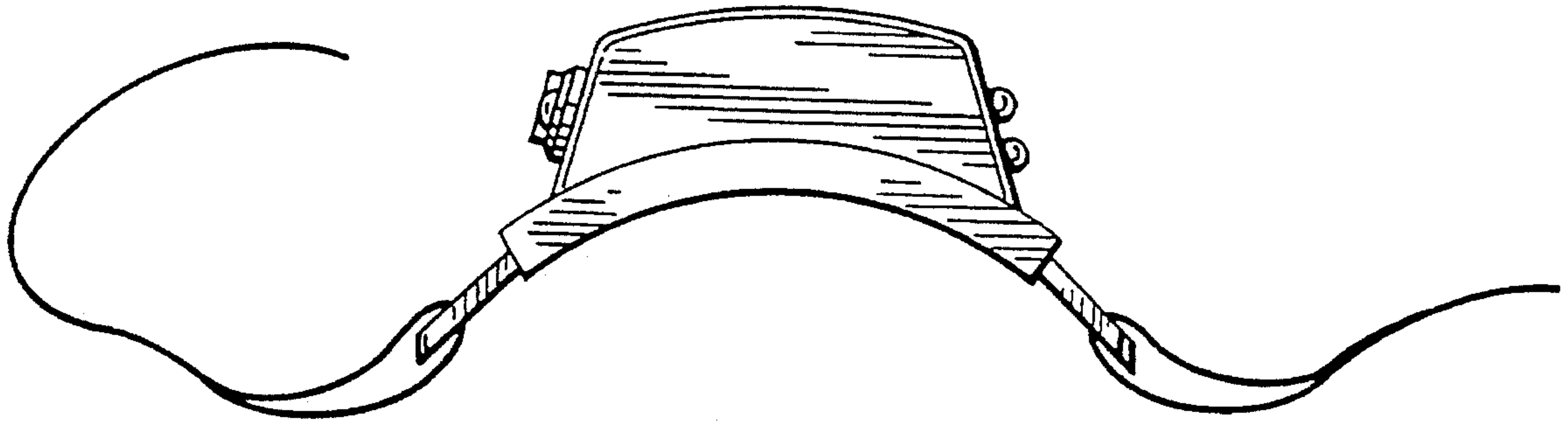

Fig. 2

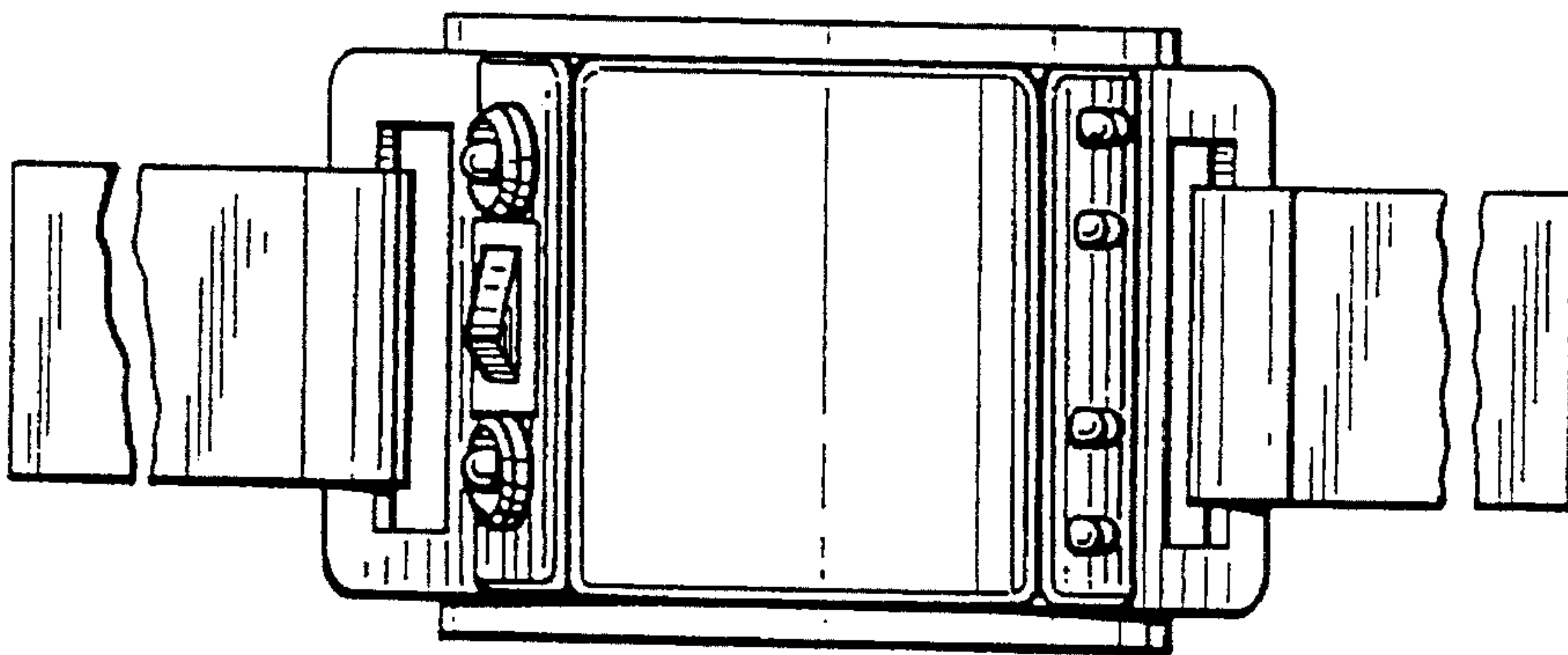

Fig. 3

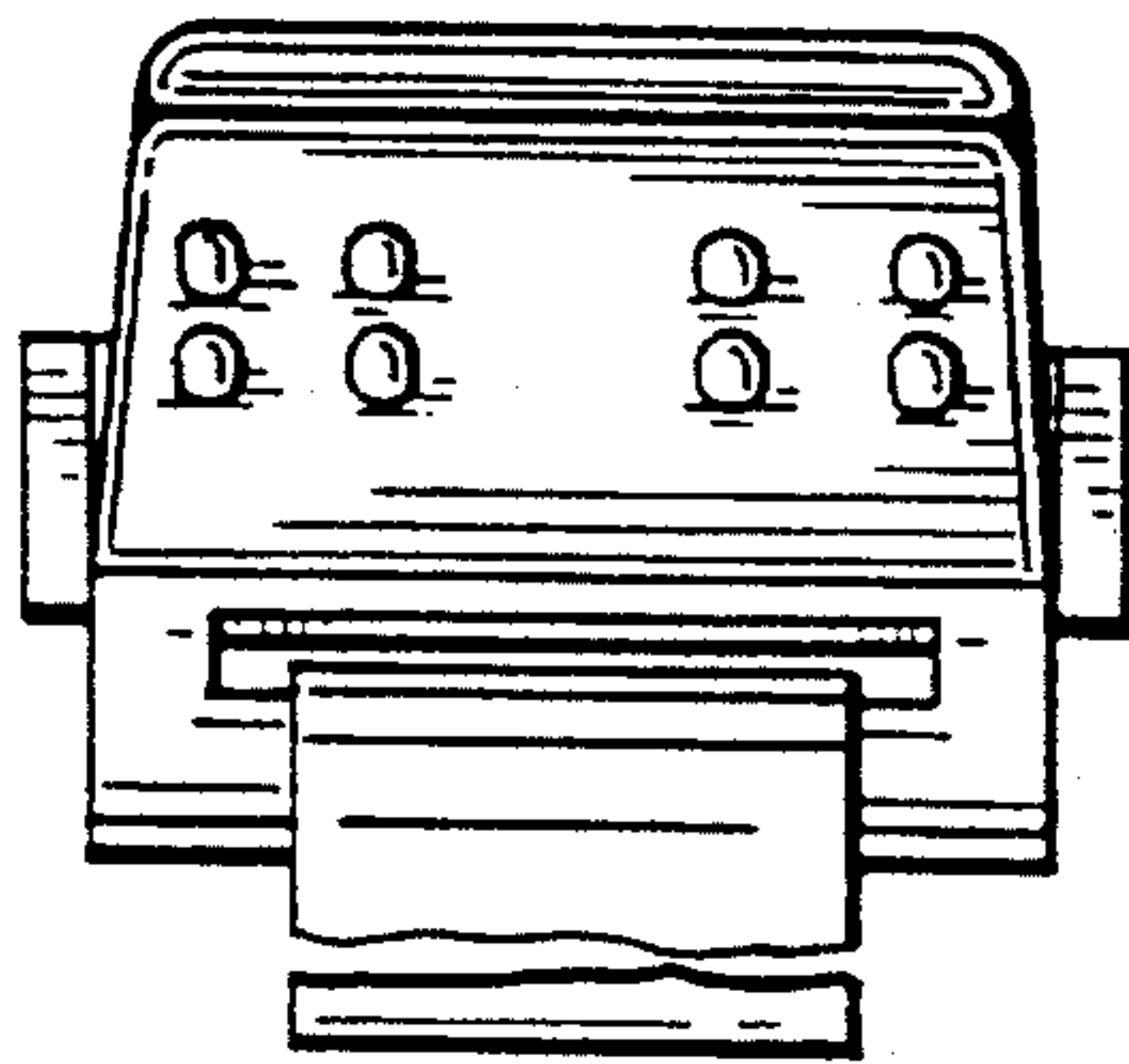

Fig. 4

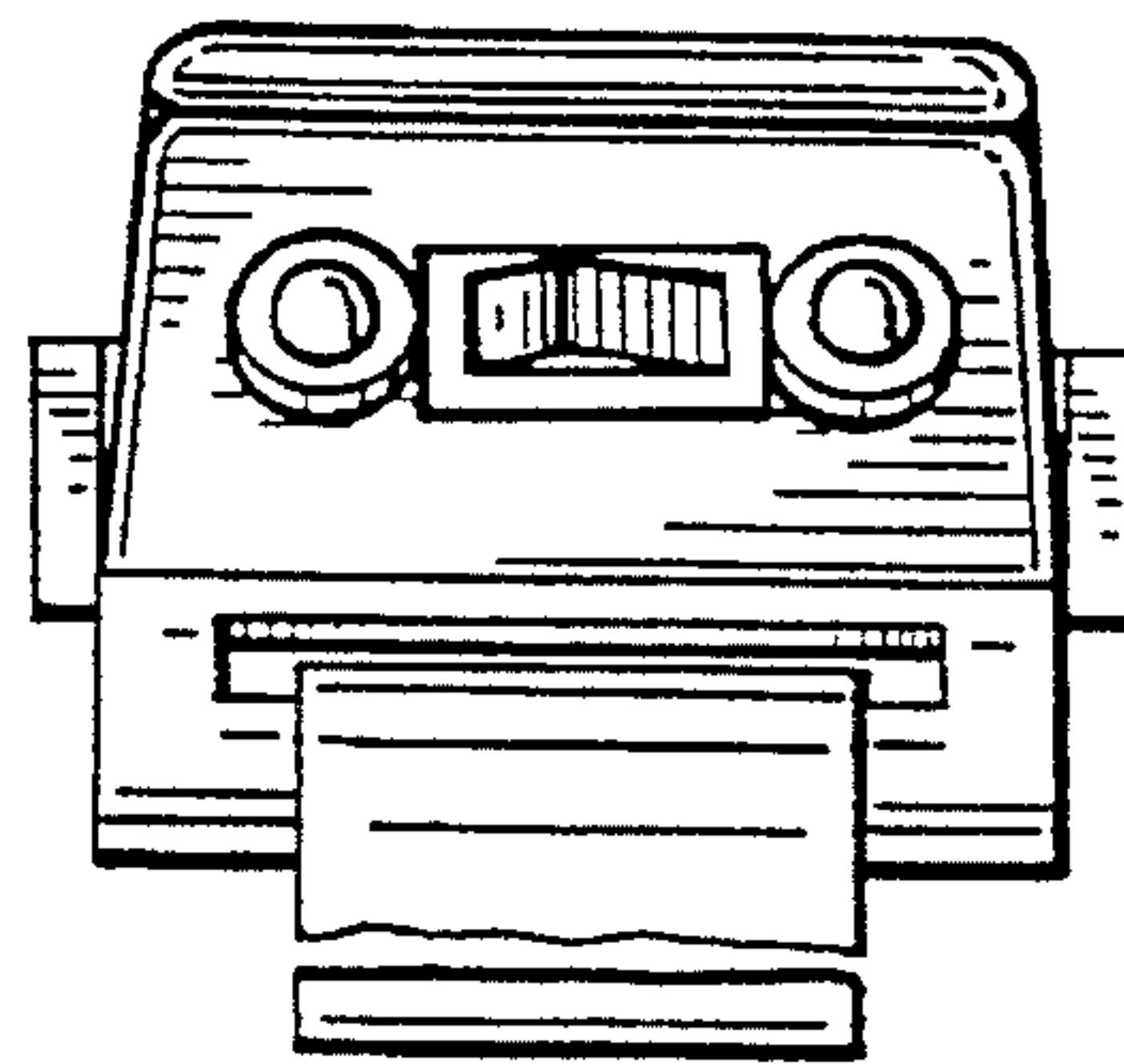

Fig. 6

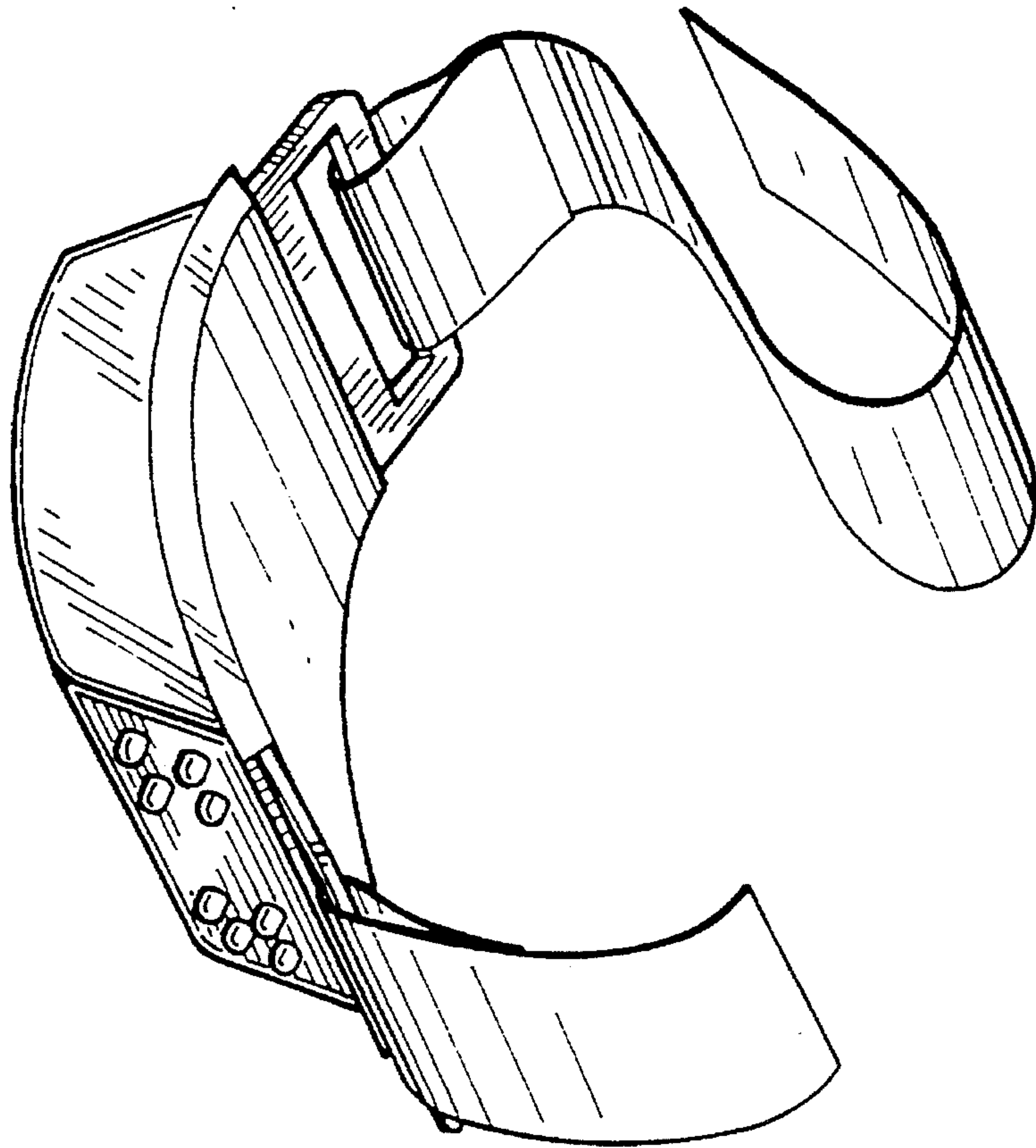

Fig. 5

