



US00D362711S

# United States Patent [19]

[11] Patent Number: **Des. 362,711**

Garrard et al.

[45] Date of Patent: **\*\*Sep. 26, 1995**

[54] **FUEL REGULATOR**

D. 311,437 10/1990 Datta et al. .... D10/49 X  
D. 314,348 2/1991 Sergi ..... D10/49

[75] Inventors: **James H. Garrard**, Kirkwood; **Eric A. Stenborg**, High Ridge; **Mark A. Jones**, St. Louis, all of Mo.

*Primary Examiner*—Stella Reid  
*Assistant Examiner*—Eric Watterson  
*Attorney, Agent, or Firm*—Kalish & Gilster

[73] Assignee: **Essex Industries, Inc.**, St. Louis, Mo.

[57] **CLAIM**

[\*\*] Term: **14 Years**

The ornamental design for a fuel regulator, as shown and described.

[21] Appl. No.: **24,432**

**DESCRIPTION**

[22] Filed: **Jun. 14, 1994**

[52] U.S. Cl. .... **D23/235**

[58] Field of Search ..... **D23/233-237,**  
**D23/244-249; 137/88, 114, 118, 233, 614.02,**  
**123/445, DIG. 10, 340, 382; D10/49**

FIG. 1 is an isometric view showing our new design;  
FIG. 2 is a right end view thereof;  
FIG. 3 is a side elevational view thereof the opposite view being a mirror image;  
FIG. 4 is a left end view thereof;  
FIG. 5 is a top plan view thereof; and,  
FIG. 6 is a bottom plan view thereof.

[56] **References Cited**

**U.S. PATENT DOCUMENTS**

D. 215,001 8/1969 Hammon ..... D23/235

**1 Claim, 1 Drawing Sheet**

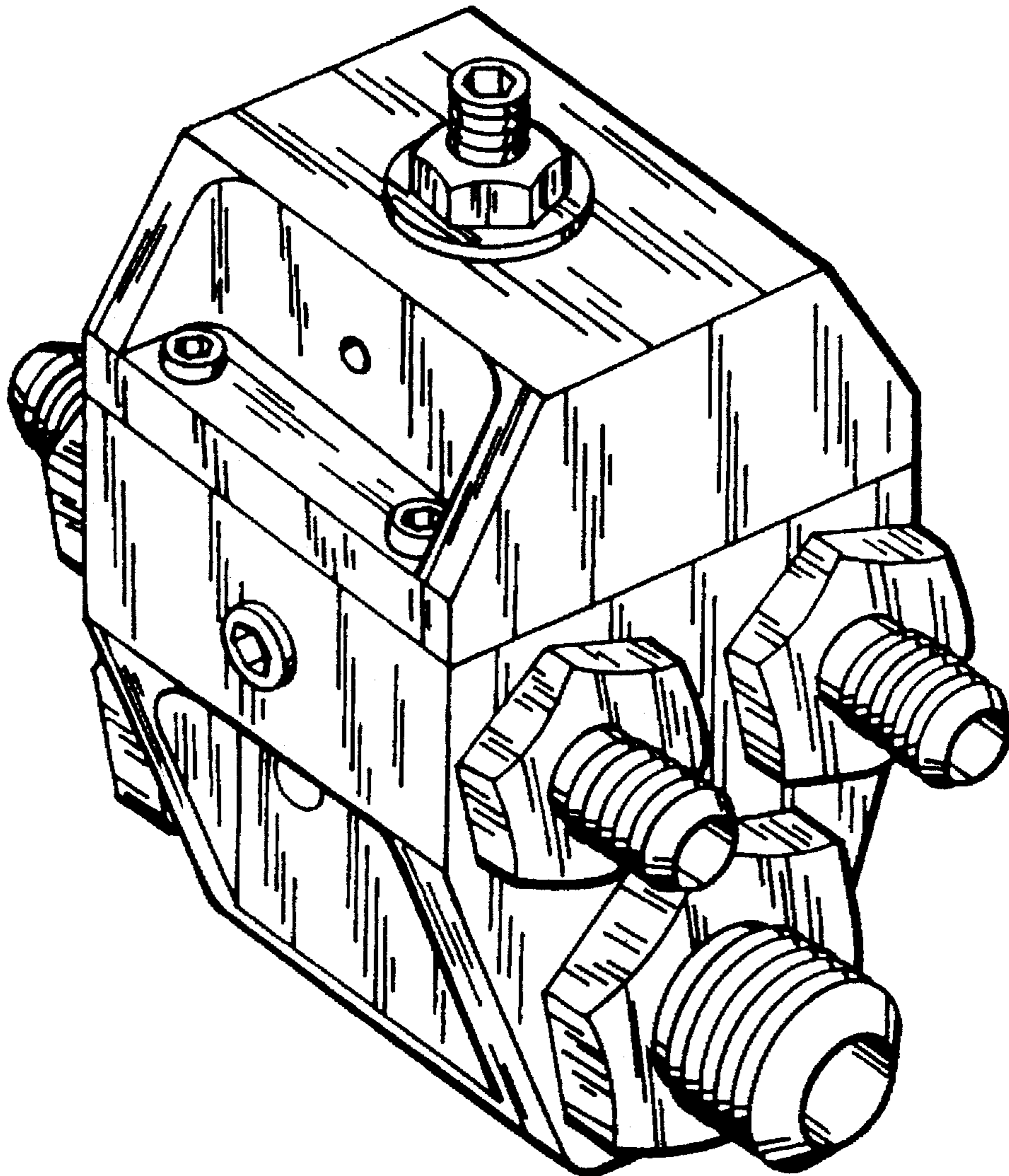

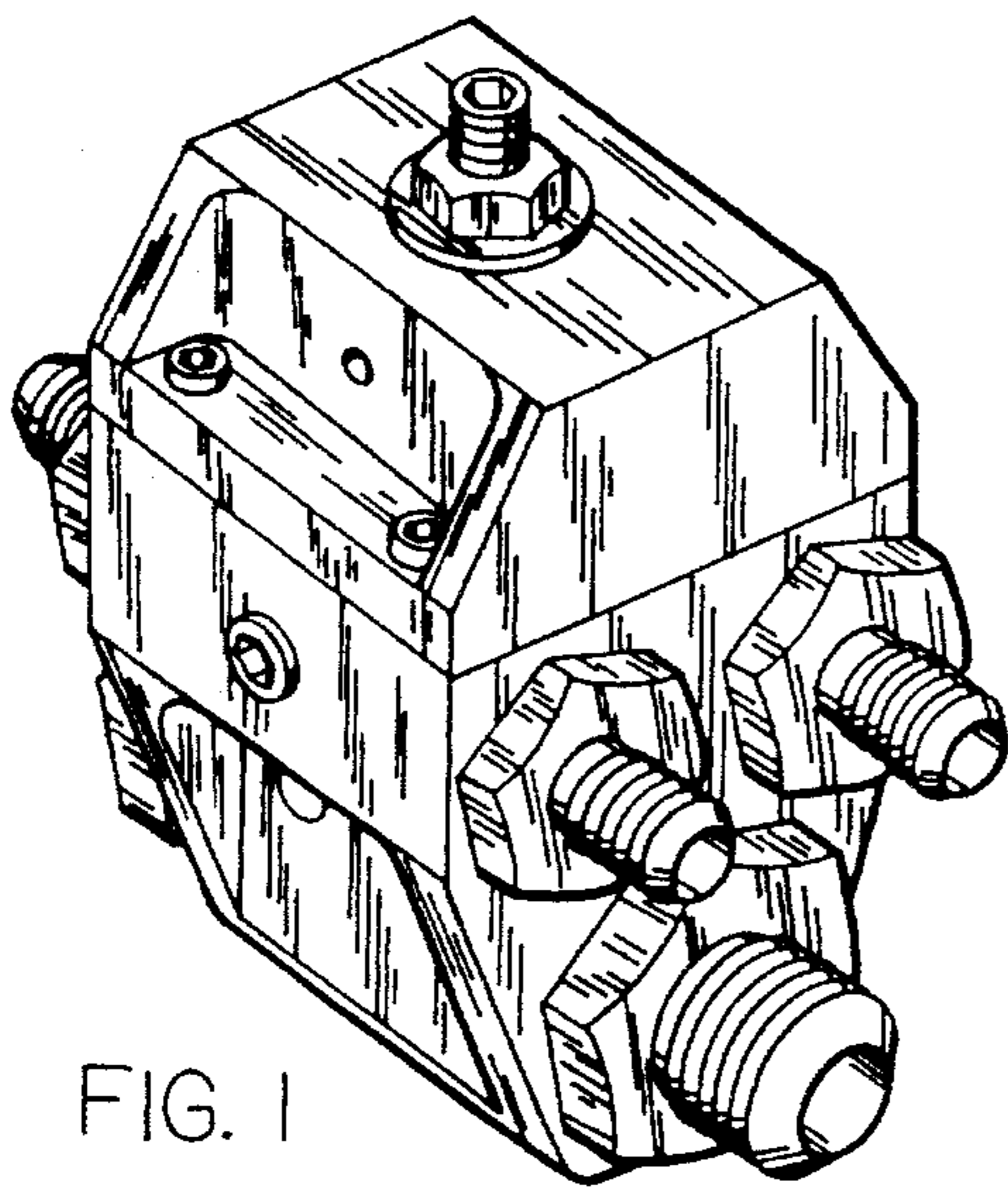

FIG. 1

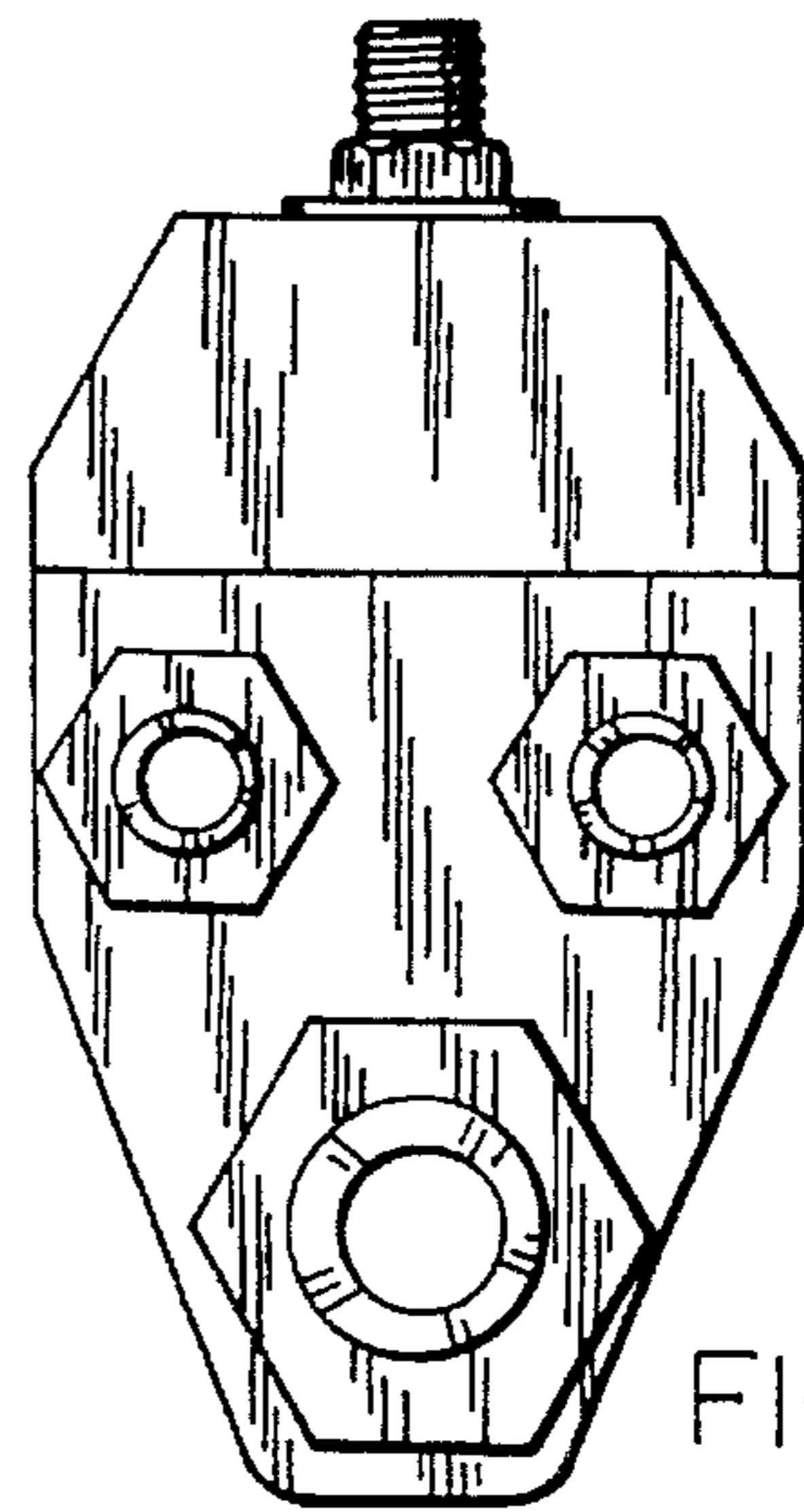

FIG. 2

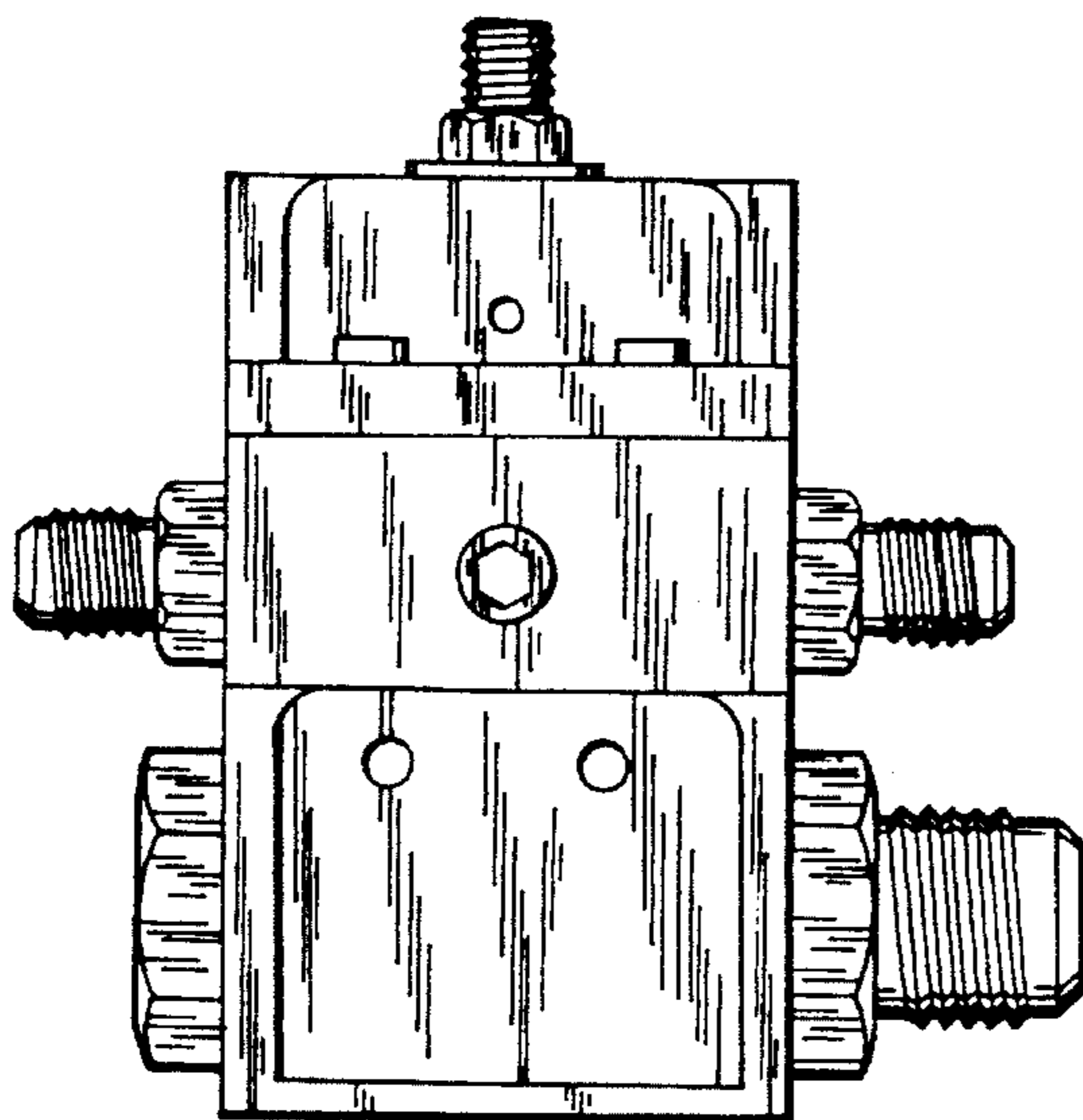

FIG. 3

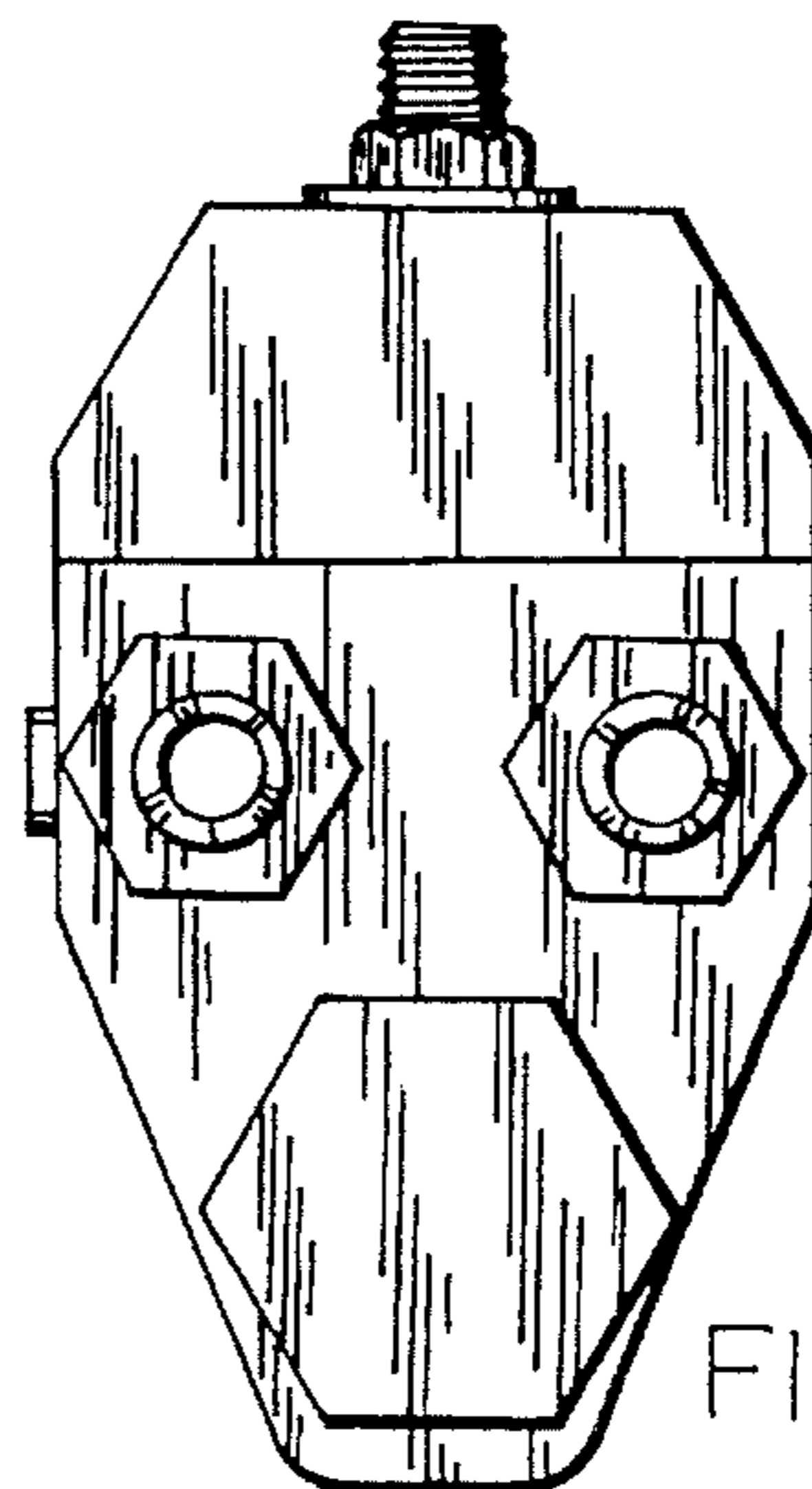

FIG. 4

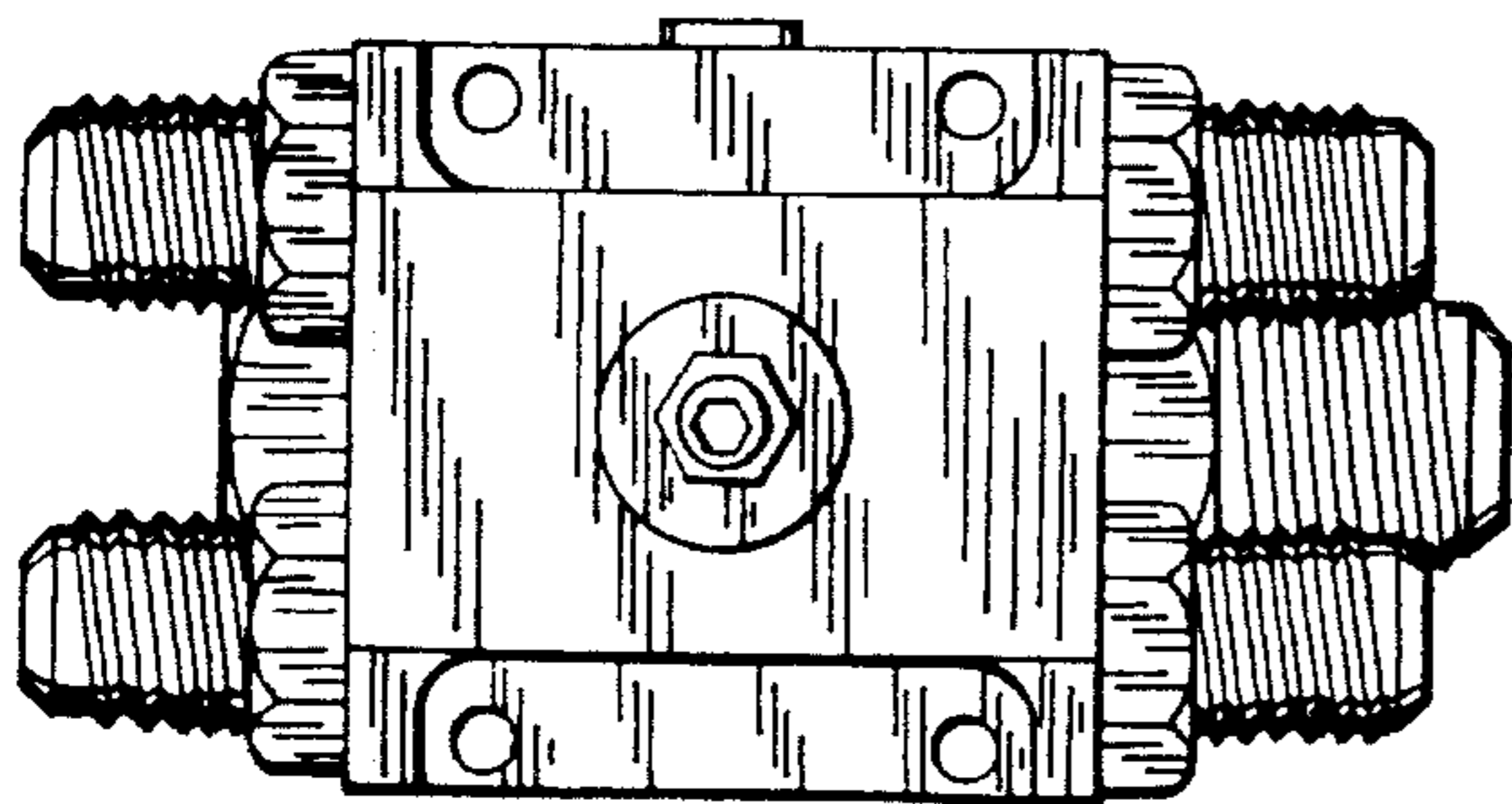

FIG. 5

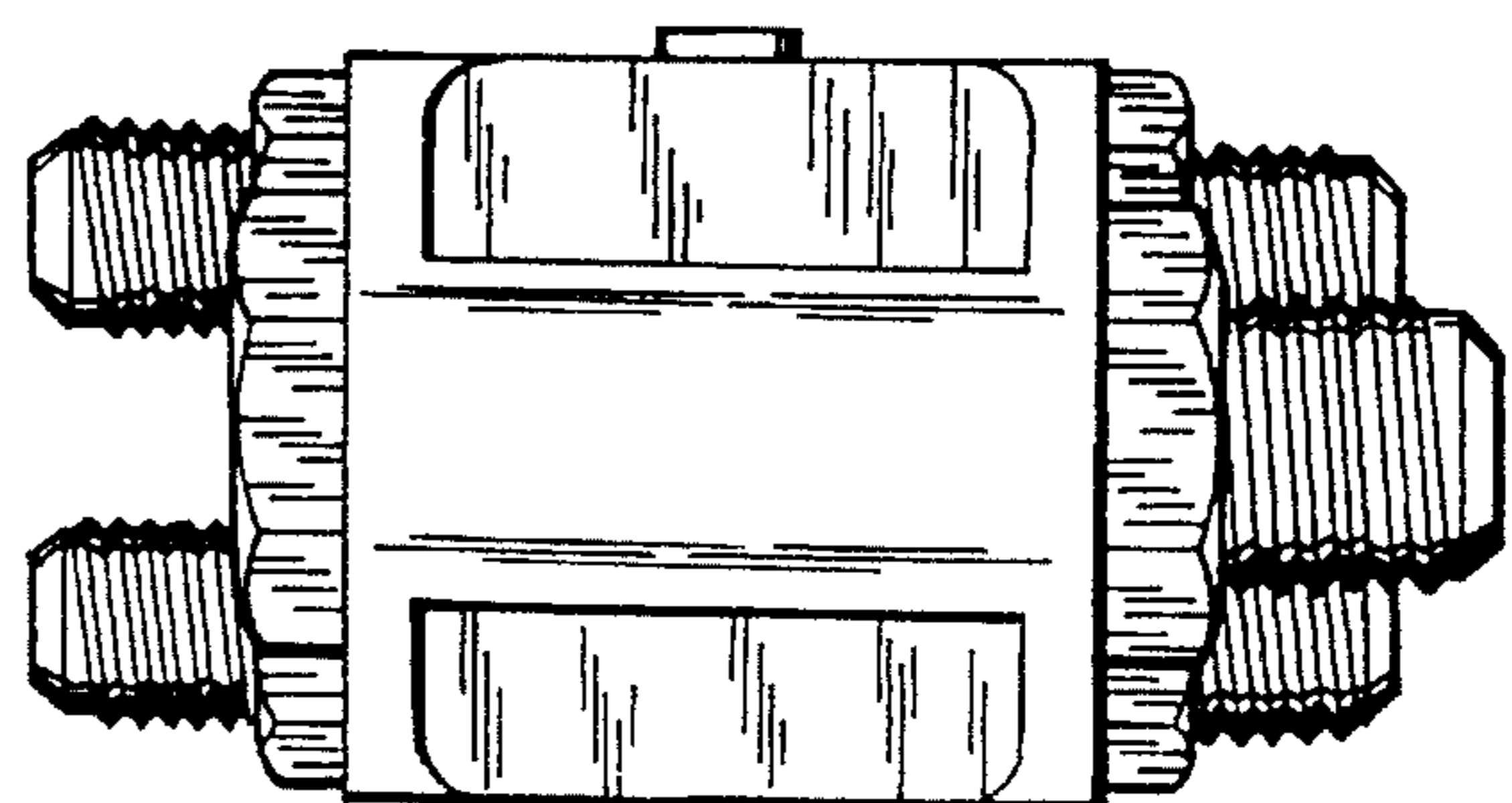

FIG. 6