



US00D362659S

United States Patent [19]

[11] **Patent Number:** **Des. 362,659**

Hedding et al.

[45] **Date of Patent:** ****Sep. 26, 1995**

[54] **ELECTRONIC TRAILER BRAKE CONTROLLER**

D. 322,426	12/1991	Austin	D13/164
D. 331,226	11/1992	Austin	D13/162
3,953,084	4/1976	Pittet, Jr. et al.	188/3 R X
5,333,948	8/1994	Austin et al.	303/24.1

[75] Inventors: **Michael A. Hedding**, Canton; **Matthew J. Knox**, Romulus, both of Mich.

FOREIGN PATENT DOCUMENTS

[73] Assignee: **Hayes Wheels International, Inc.**, Romulus, Mich.

113096 12/1991 Australia .

[**] Term: **14 Years**

Primary Examiner—Joel Sincavage
Attorney, Agent, or Firm—MacMillan, Sobanski & Todd

[21] Appl. No.: **28,954**

[57] CLAIM

[22] Filed: **Sep. 26, 1994**

The ornamental design for an electronic trailer brake controller, as shown and described.

[52] U.S. Cl. **D13/162**

DESCRIPTION

[58] **Field of Search** D13/126, 162, D13/164; 180/271; 188/3 R; 303/9.68, 24.1

FIG. 1 is a right front perspective view of an electronic trailer brake controller showing my new design; FIG. 2 is a left front perspective view of the controller shown in FIG. 1; FIG. 3 is a rear elevational view of the controller shown in FIG. 1; and, FIG. 4 is a bottom view of the controller shown in FIG. 1.

[56] References Cited

U.S. PATENT DOCUMENTS

D. 257,973 1/1981 Reid D13/126 X

1 Claim, 3 Drawing Sheets

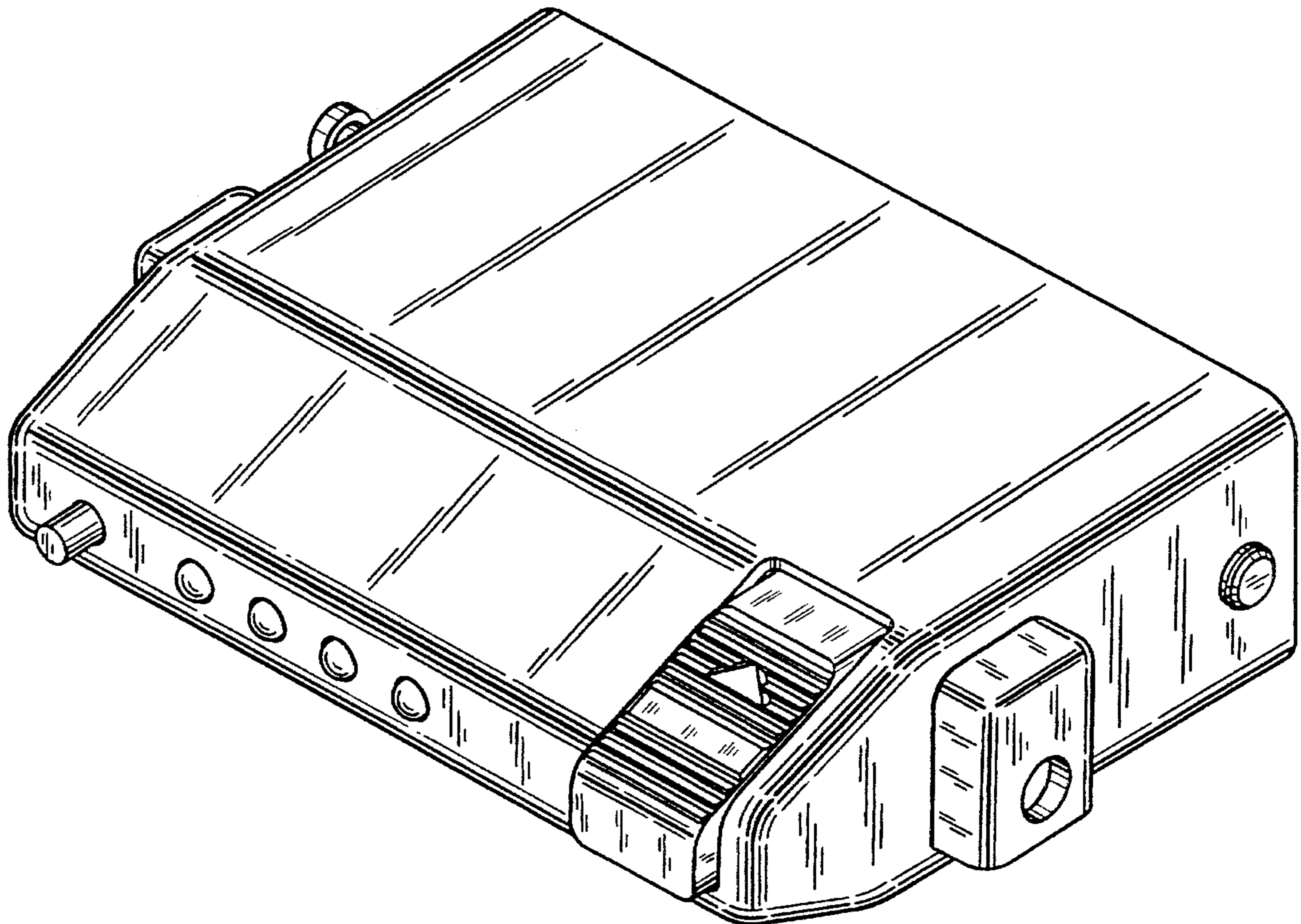

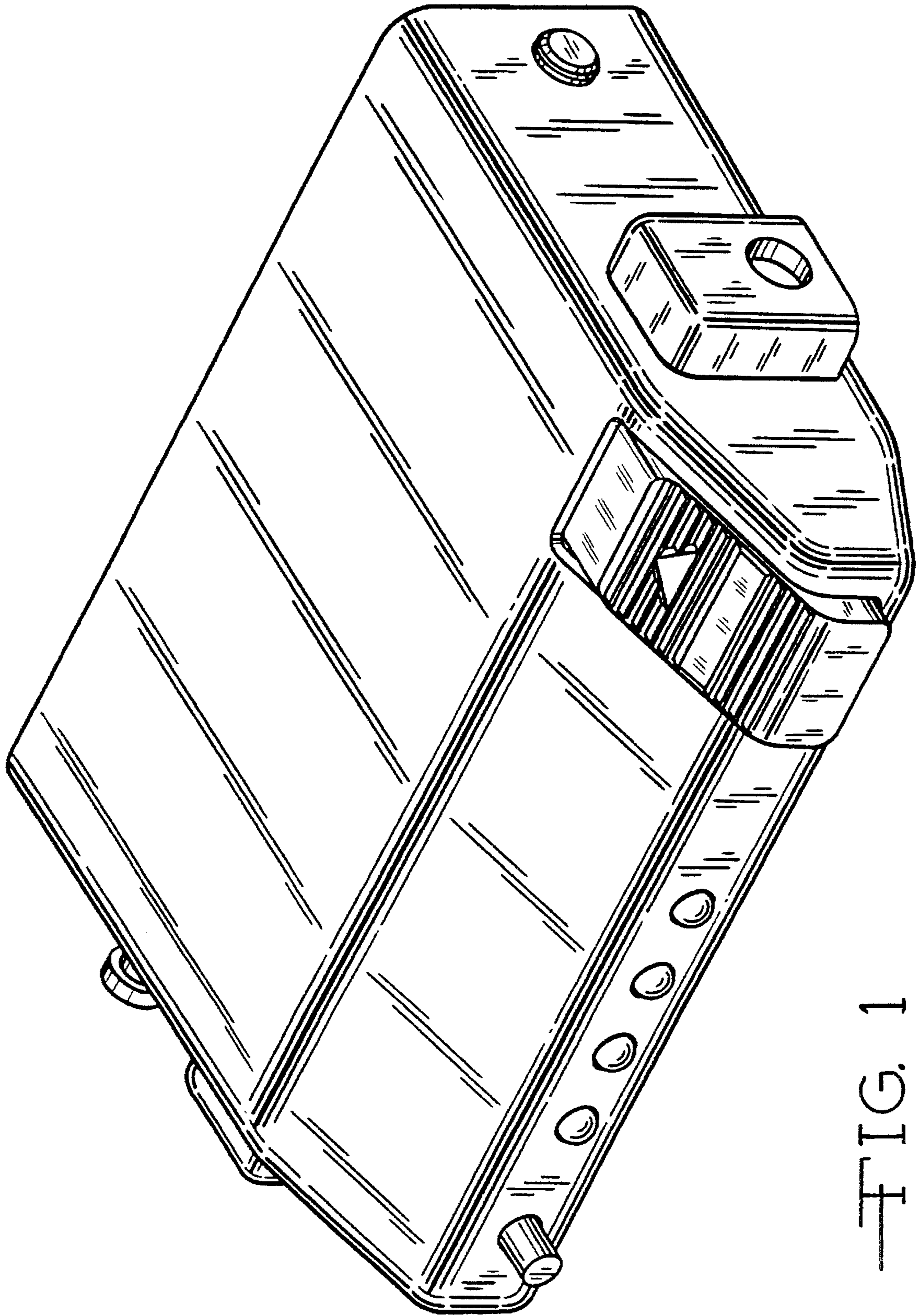
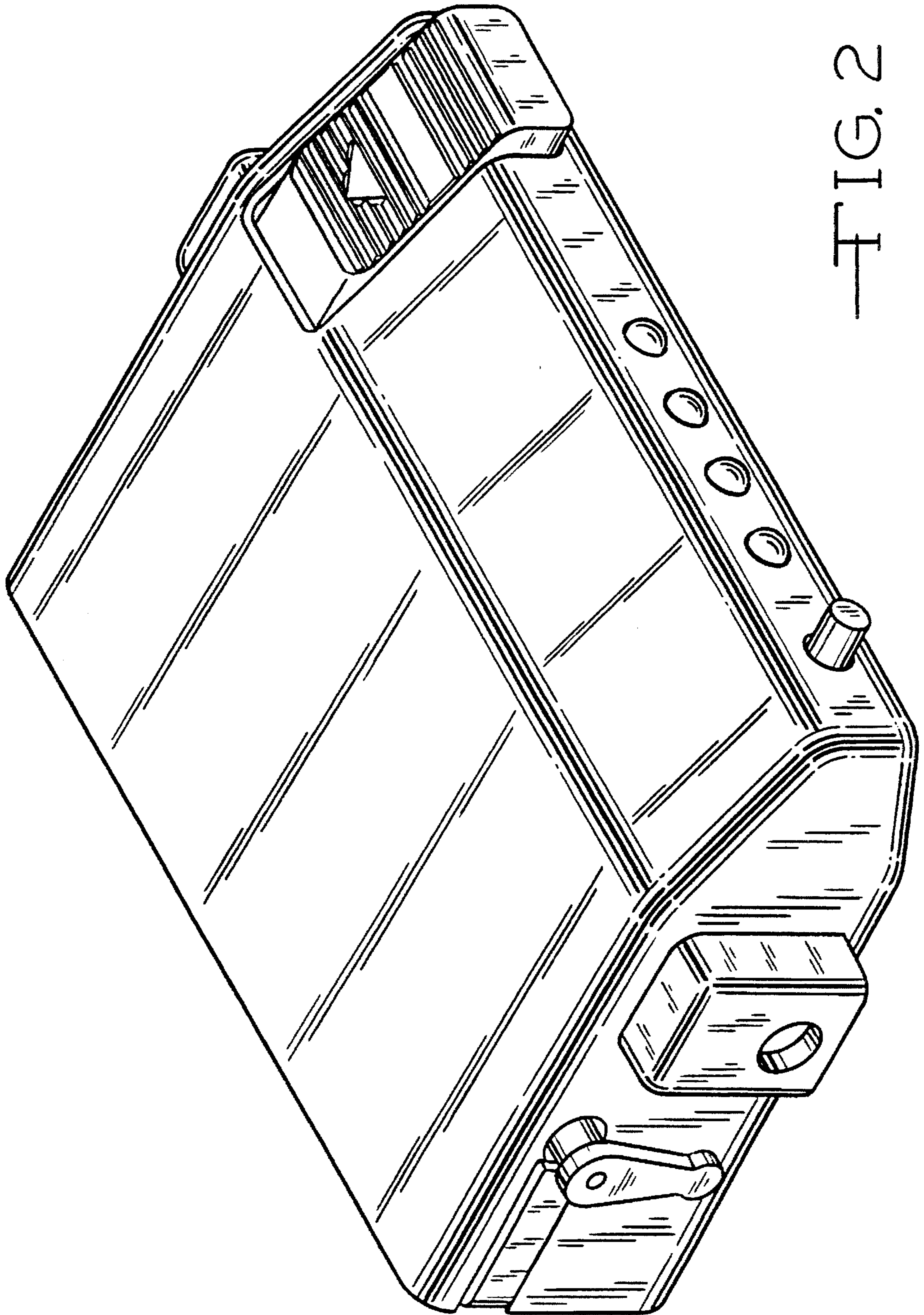
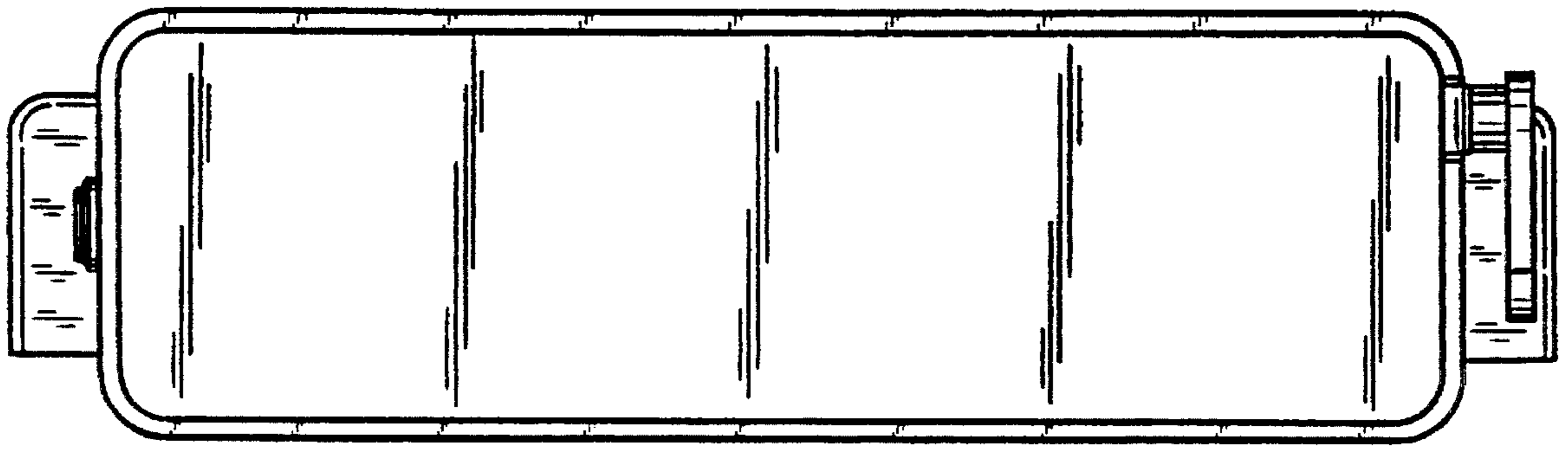

FIG. 1



—FIG. 2



—FIG. 3

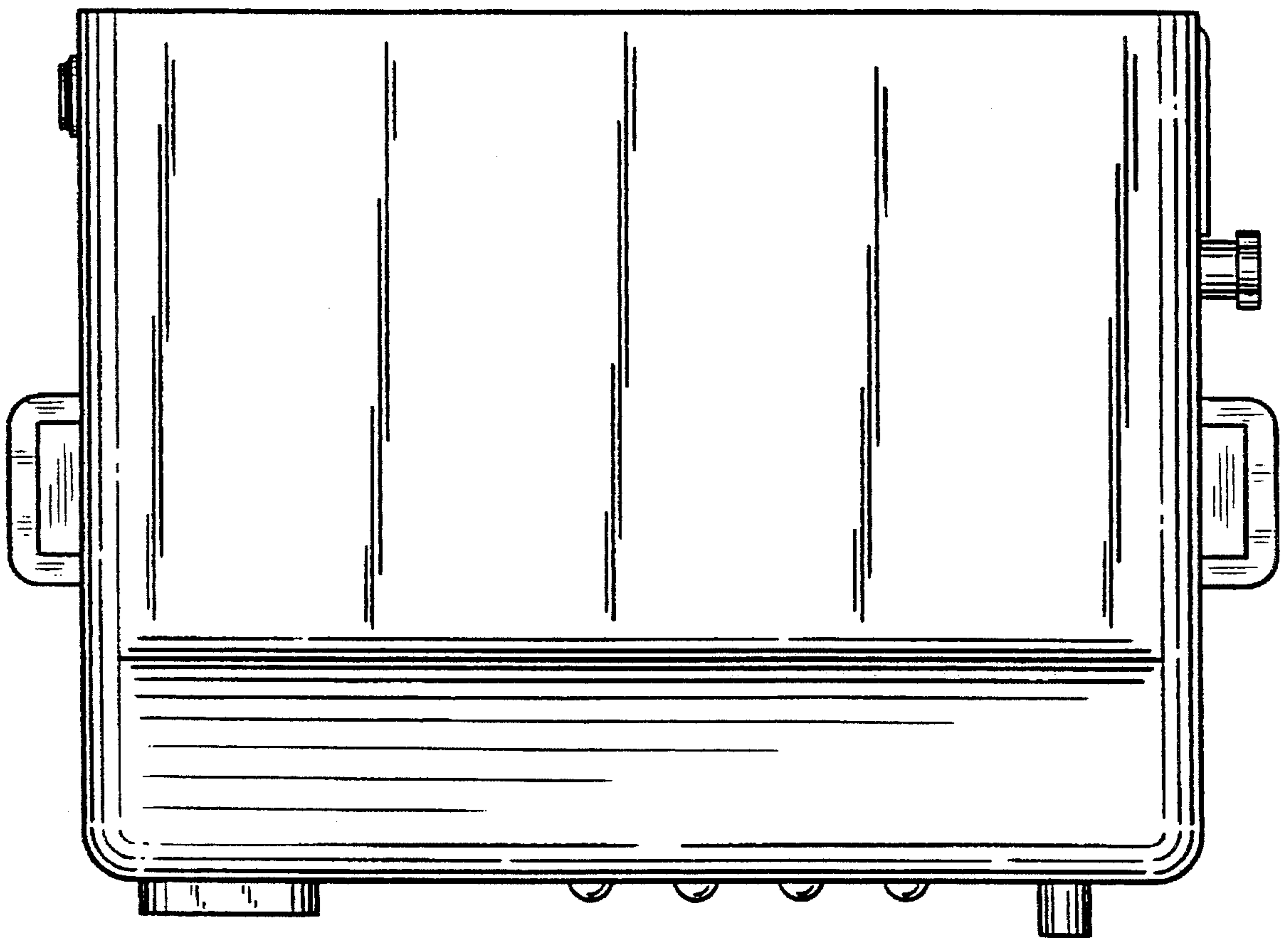

—FIG. 4