



US00D362654S

# United States Patent [19]

[11] **Patent Number:** **Des. 362,654**

**Keith**

[45] **Date of Patent:** **\*\*Sep. 26, 1995**

[54] **TRUCK BED RACK**

FOREIGN PATENT DOCUMENTS

[76] Inventor: **Robert M. Keith**, 808 Clinton St., Sanford, Fla. 32771

1124807 10/1956 France ..... D12/412

[\*\*] Term: **14 Years**

OTHER PUBLICATIONS

[21] Appl. No.: **24,627**

Popular Mechanics, May 1984, p. 66, the bike cart construction frame assembly.

[22] Filed: **Jun. 17, 1994**

*Primary Examiner*—A. Hugo Word

*Assistant Examiner*—M. Brown

*Attorney, Agent, or Firm*—William M. Hobby, III

[52] U.S. Cl. .... **D12/406**

[58] **Field of Search** ..... D12/412, 406; 296/3, 26, 27, 100; 224/42.44 R, 42.45 R, 309, 315

[57] **CLAIM**

The ornamental design for a truck bed rack, as shown and described.

[56] **References Cited**

**DESCRIPTION**

U.S. PATENT DOCUMENTS

D. 236,973	9/1975	Burton	.....	D12/412
D. 292,504	10/1987	Racieot	.....	D12/412
D. 318,447	7/1991	Haugen et al.	.....	D12/412
4,057,281	11/1977	Garrett	.....	D12/412
4,278,175	7/1981	Jackson	.....	D12/412
4,770,458	9/1988	Burke et al.	.....	224/42.45 R
5,143,415	9/1992	Boudah	.....	224/325

FIG. 1 is a perspective view of my new truck bed rack; FIG. 2 is a top plan view; FIG. 3 is a bottom plan view; FIG. 4 is an end elevation view; FIG. 5 is a side elevation view, the opposite side is a mirror image of that shown; and, FIG. 6 is an opposite end elevation view.

**1 Claim, 1 Drawing Sheet**

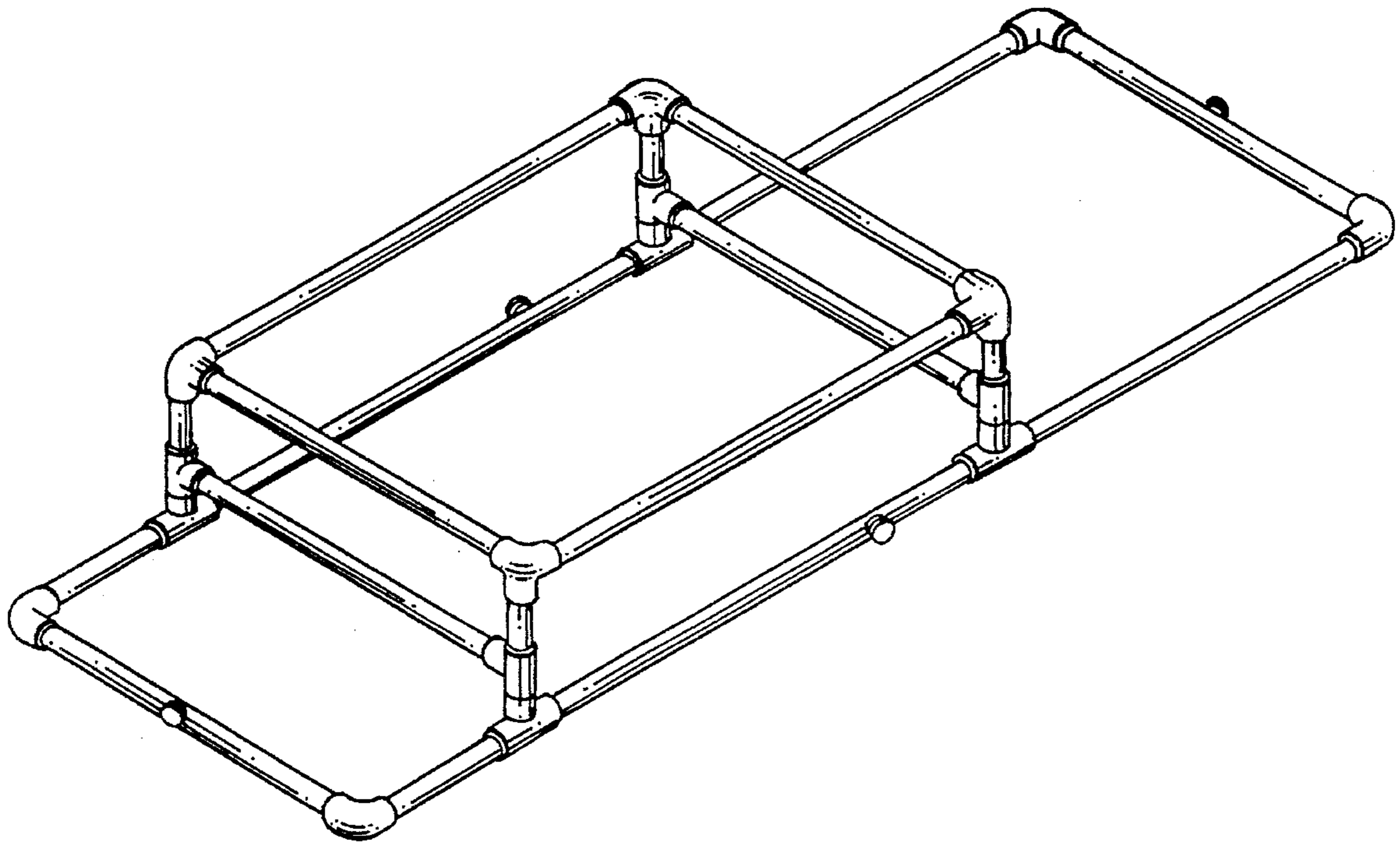

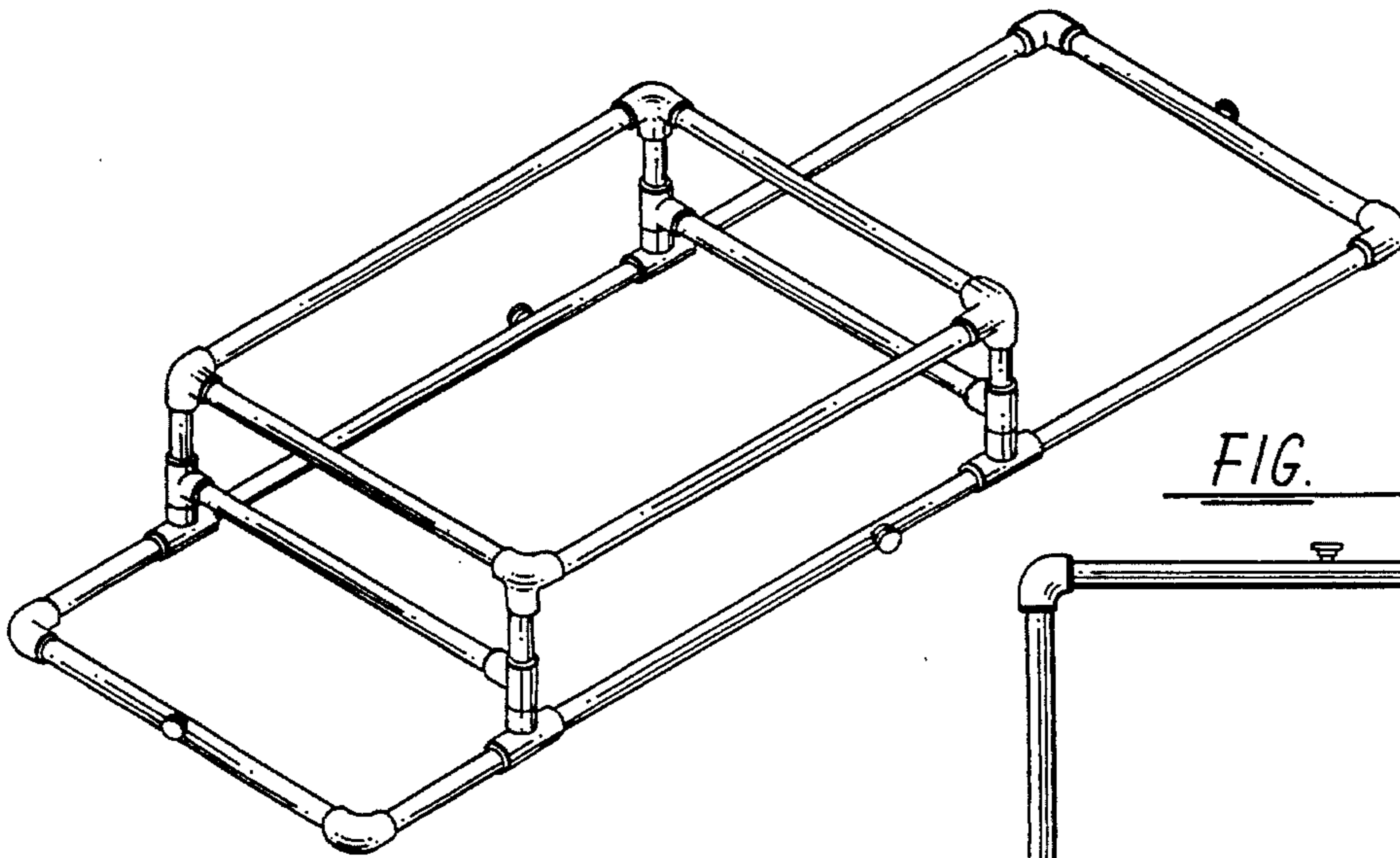

FIG. 1

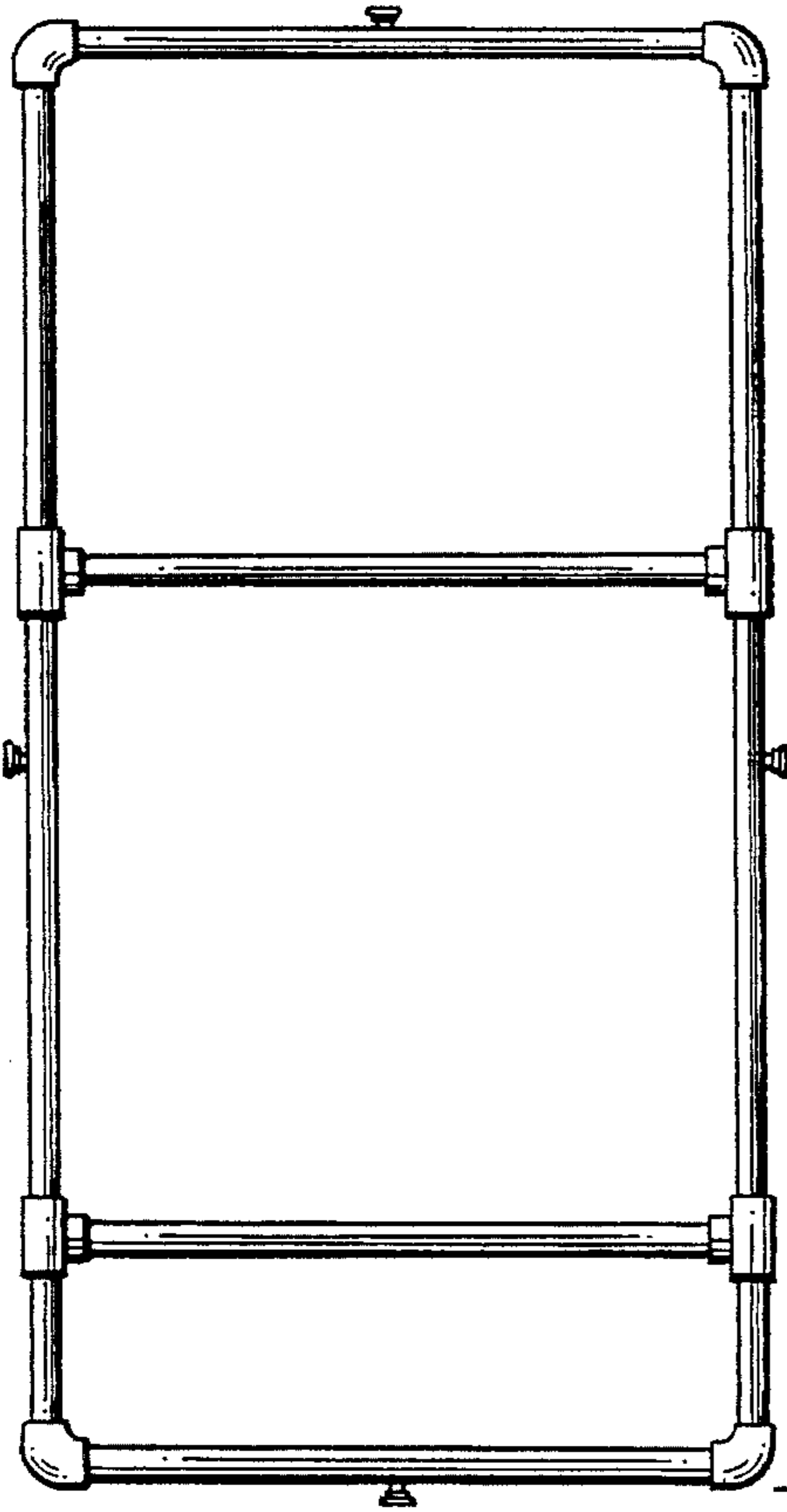

FIG. 2

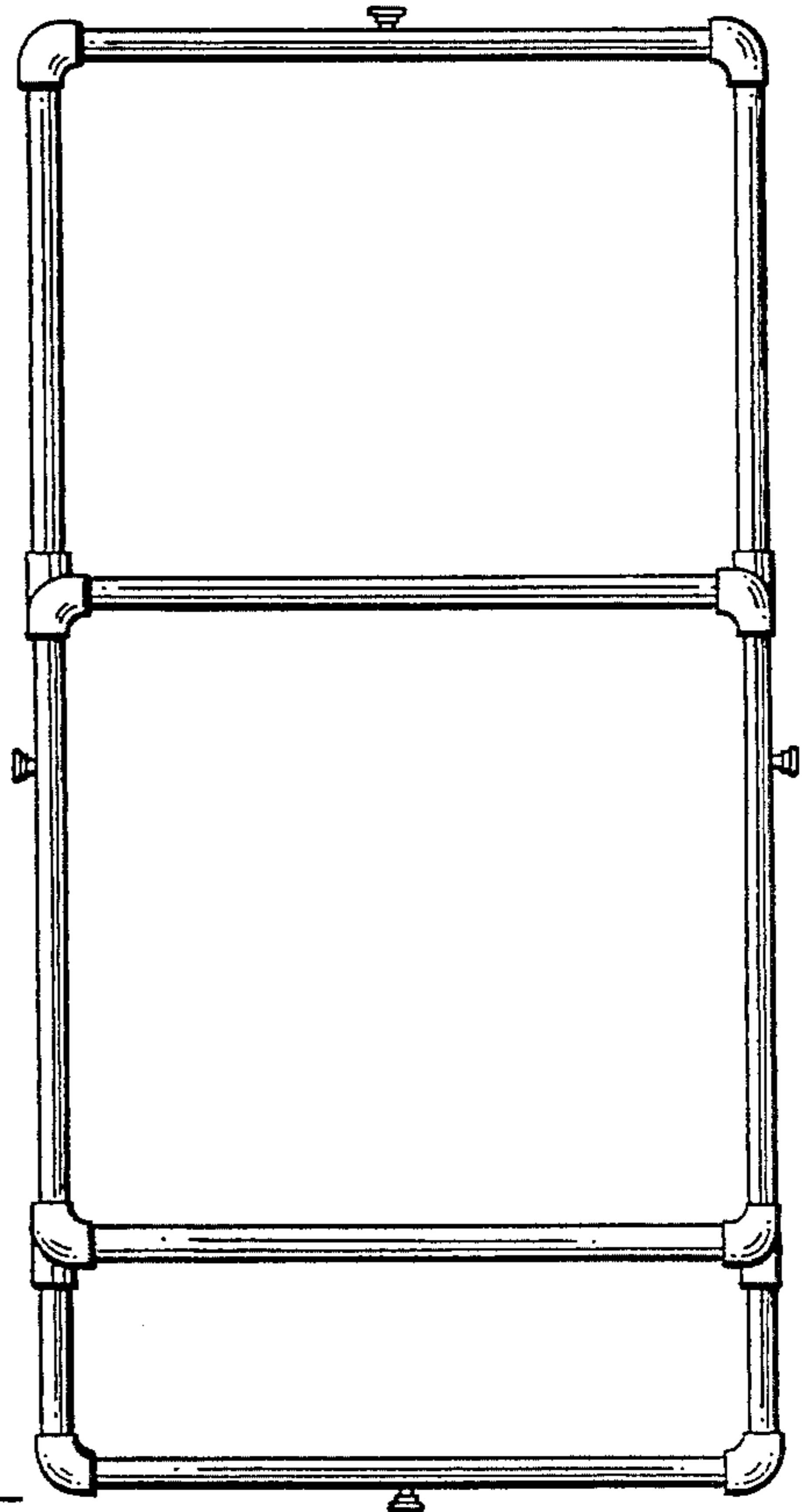

FIG. 3

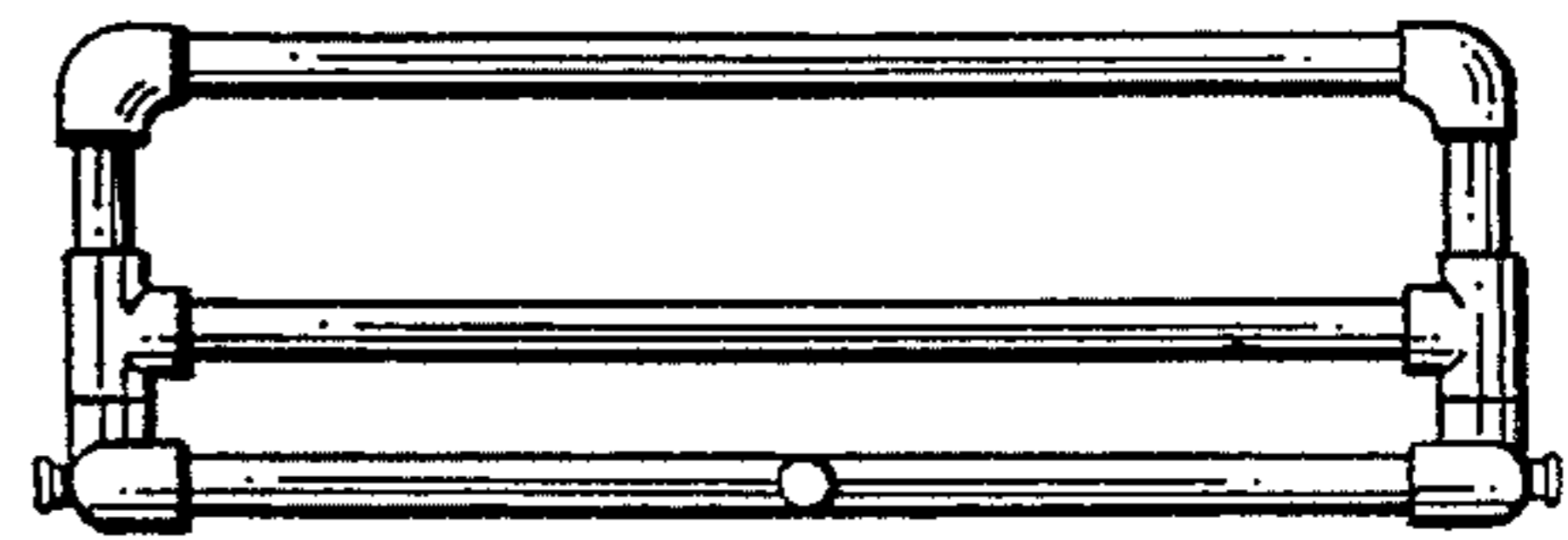

FIG. 4

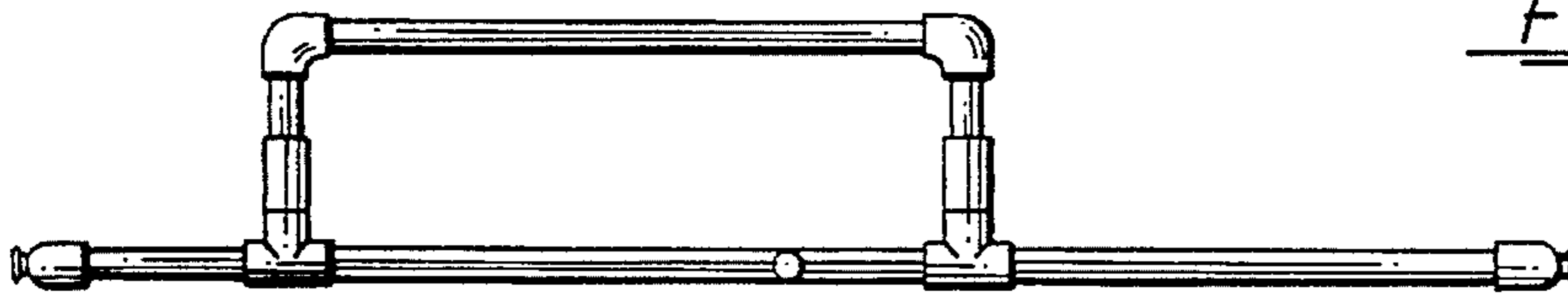

FIG. 5

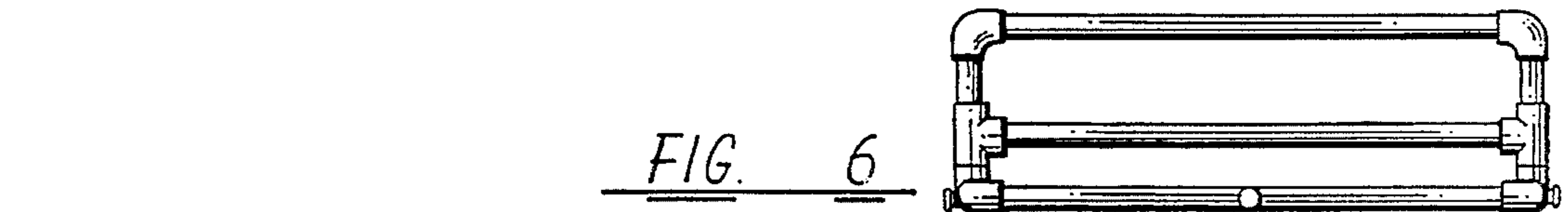

FIG. 6