



US00D362503S

United States Patent [19]

[11] Patent Number: Des. 362,503

Cook et al.

[45] Date of Patent: ** Sep. 19, 1995

[54] **OFFSET ADAPTOR FOR AN ORTHOPAEDIC DRIVER INSTRUMENT**

[75] Inventors: **Kevin S. Cook**, Winona Lake; **Charles D. Persons**, Columbia City, both of Ind.

[73] Assignee: **Zimmer, Inc.**, Warsaw, Ind.

[**] Term: **14 Years**

[21] Appl. No.: **17,981**

[22] Filed: **Jan. 26, 1994**

[52] U.S. Cl. **D24/133**

[58] Field of Search **D24/133, 140; 606/90, 606/53, 99, 100; D8/29, 14**

[56] **References Cited**

U.S. PATENT DOCUMENTS

D. 290,399	6/1987	Kitchens	D24/26
4,622,959	11/1986	Marcus	128/92 YZ
4,667,664	5/1987	Taylor et al.	128/92 VV
4,993,410	2/1991	Kimsey	606/100
5,169,401	12/1992	Lester et al.	606/99 X
5,196,018	3/1993	Willert et al.	606/99
5,284,484	2/1994	Hood et al.	606/90 X
5,352,230	10/1994	Hood et al.	606/99

OTHER PUBLICATIONS

Depuy literature—F.I.N. Flexible Intramedullary Nail Instrumentation (No date available, but acknowledged as prior art).
 Synthes catalog pp. 144–145—Insertion-Extraction Instruments—1983.
 Zimmer literature—Kuntscher Intramedullary Nail System—1987.
 Zimmer literature—ZMS Intramedullary Fixation System—1992.
 Abeles & Denton—“Use of the Tibial Curved Driving

Piece for AO Femoral Nail Insertion”—Orthopaedic Review—Jul. 1992.

Primary Examiner—Louis S. Zarfes
Assistant Examiner—I. Simmons
Attorney, Agent, or Firm—Margaret L. Geringer

[57] **CLAIM**

The ornamental design for an offset adaptor for an orthopaedic driver instrument, as shown and described.

DESCRIPTION

FIG. 1 is a perspective view of an offset adaptor for an orthopaedic driver instrument;
 FIG. 2 is a side elevation view thereof;
 FIG. 3 is an end elevational view thereof;
 FIG. 4 is a side elevational view thereof of the side opposite the side shown in FIG. 2;
 FIG. 5 is an end elevational view thereof of the end opposite the end shown in FIG. 3;
 FIG. 6 is a top plan view thereof;
 FIG. 7 is a bottom plan view thereof;
 FIG. 8 is a perspective view of a second embodiment of an offset adaptor for an orthopaedic driver instrument;
 FIG. 9 is a side elevational view thereof;
 FIG. 10 is an end elevational view thereof;
 FIG. 11 is a side elevational view thereof of the side opposite the side shown in FIG. 9;
 FIG. 12 is an end elevational view thereof of the end opposite the end shown in FIG. 10;
 FIG. 13 is a top plan view thereof; and,
 FIG. 14 is a bottom plan view thereof.
 The broken line showing in FIGS. 1–14 is for illustrative purposes only and forms no part of the claimed design.

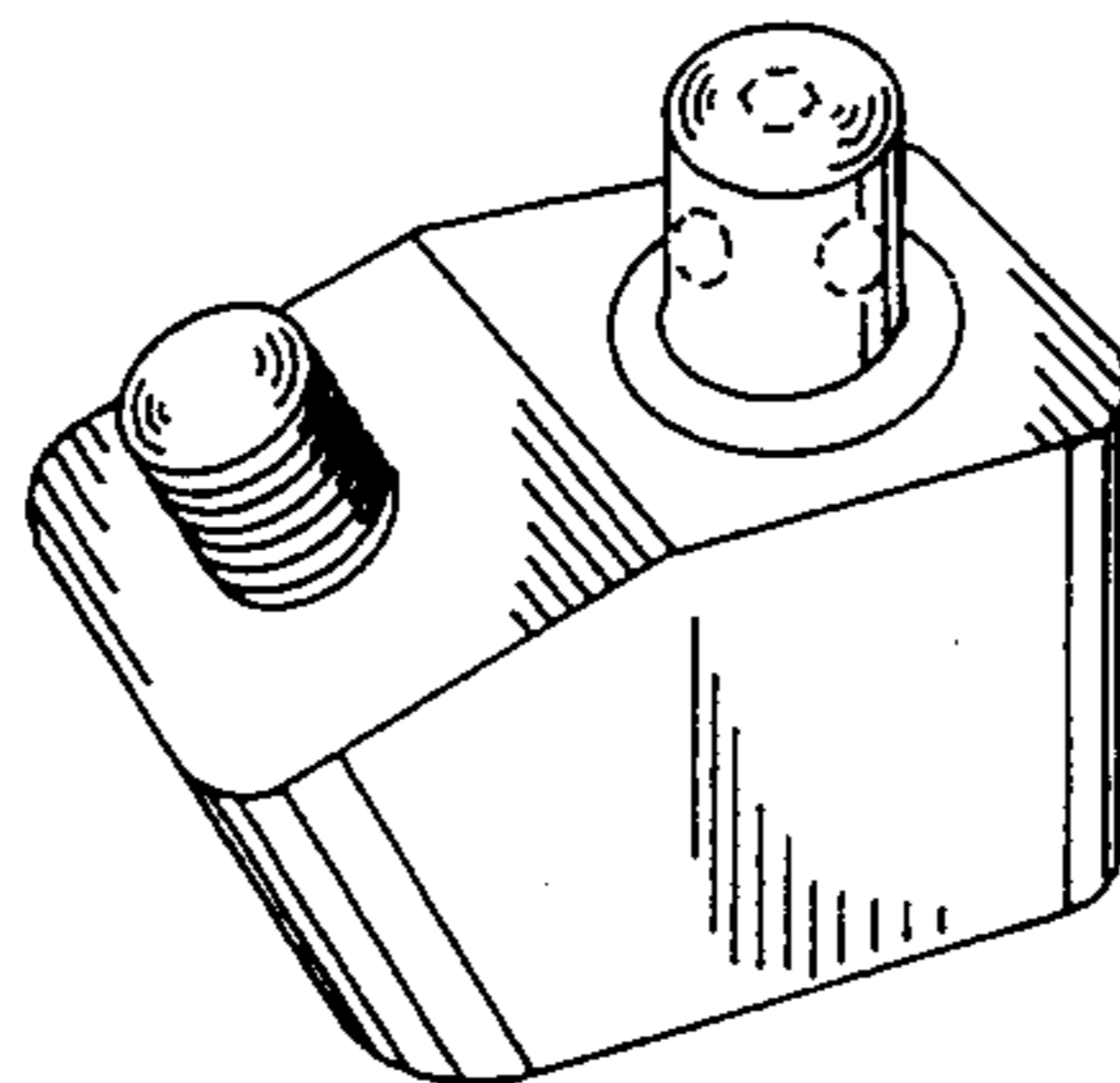
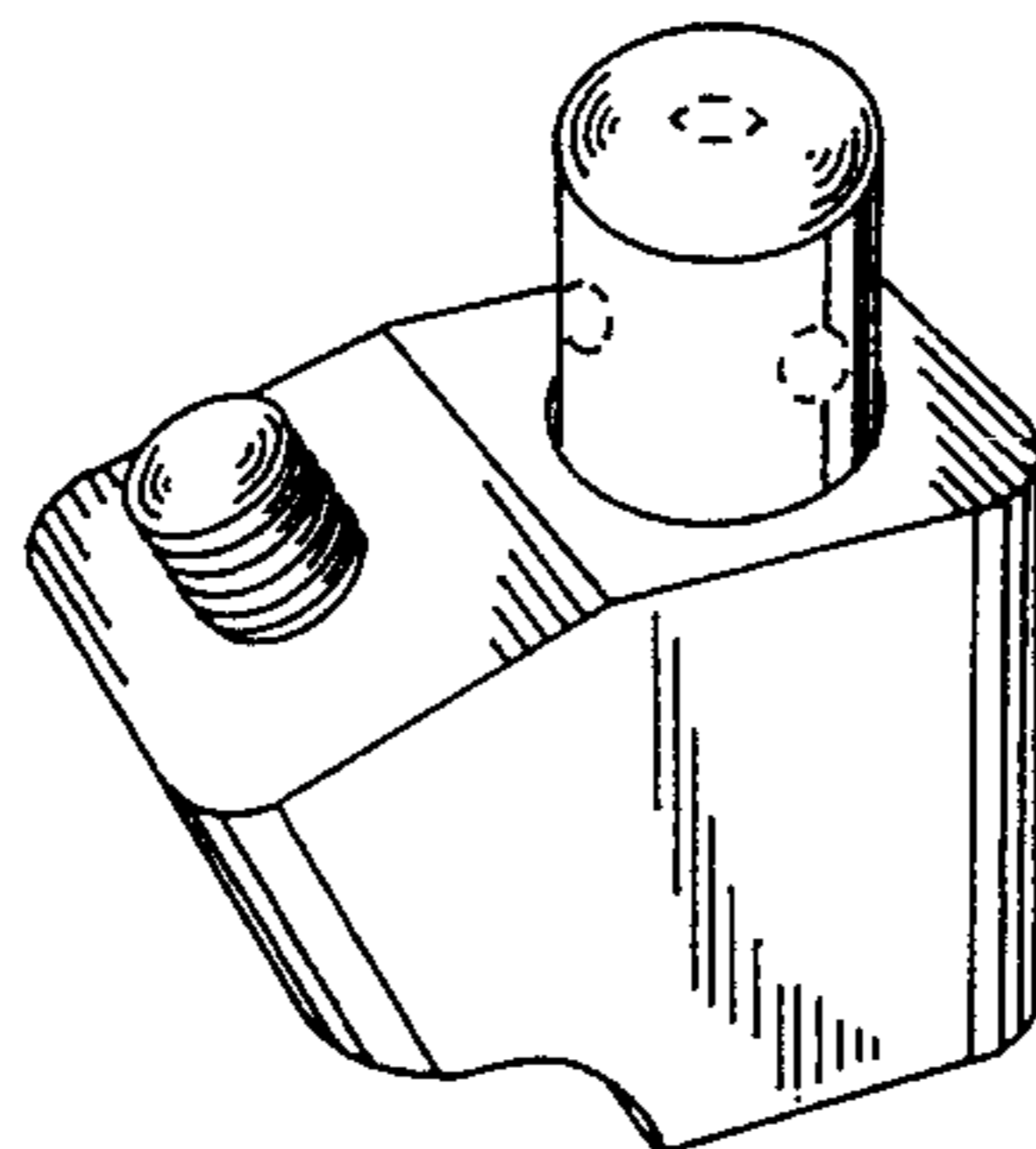

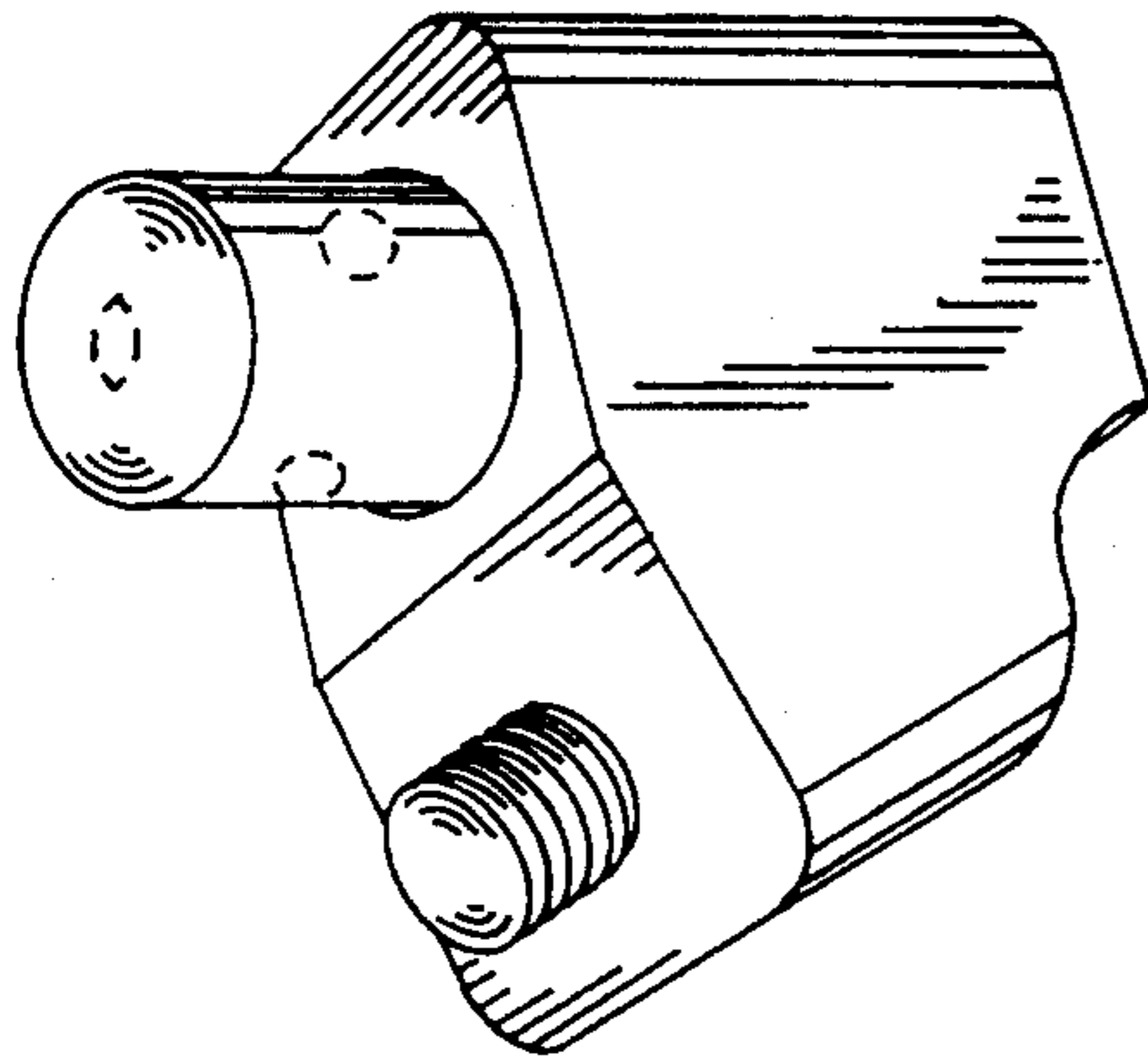

FIG. 1

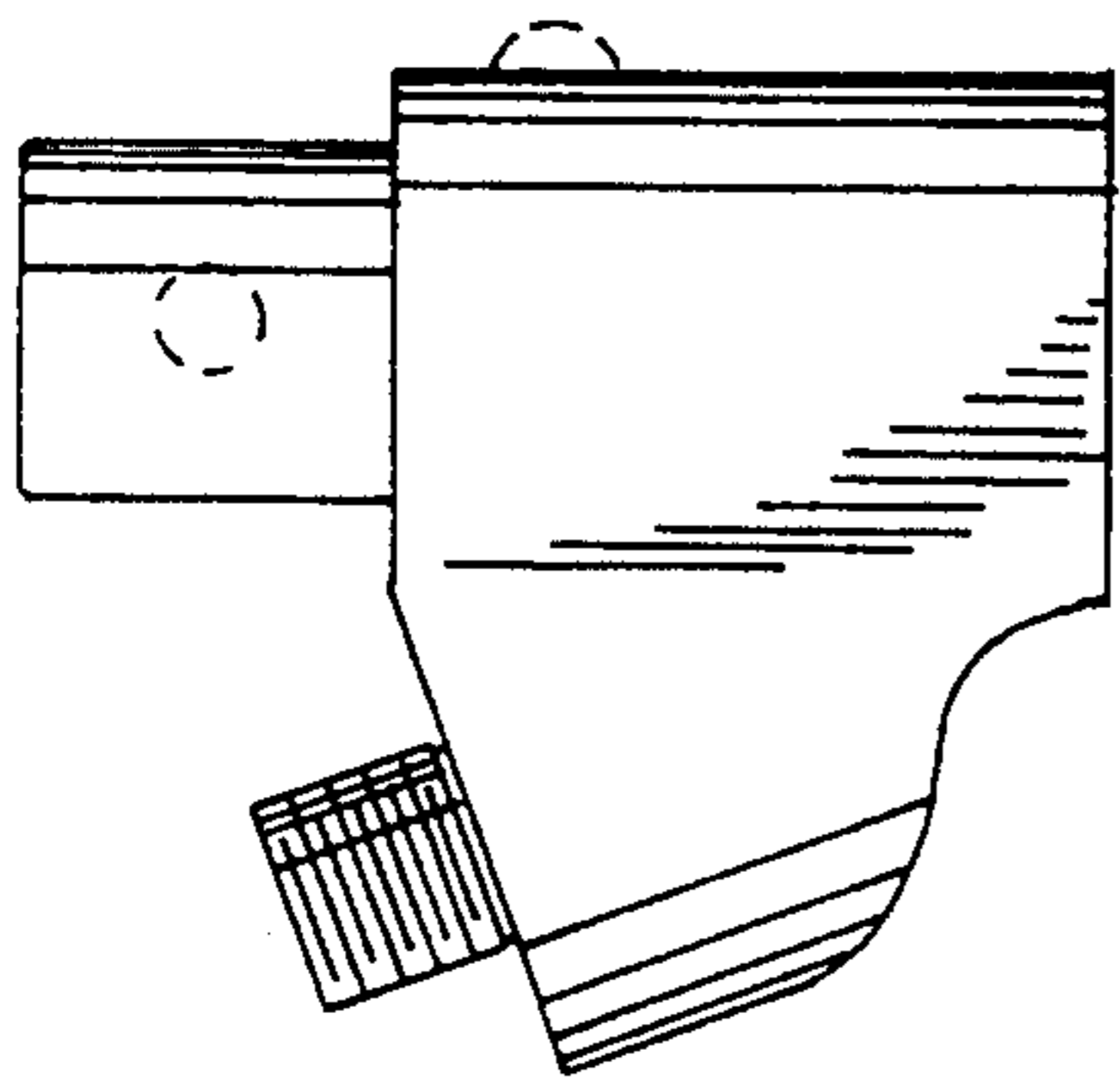

FIG. 2

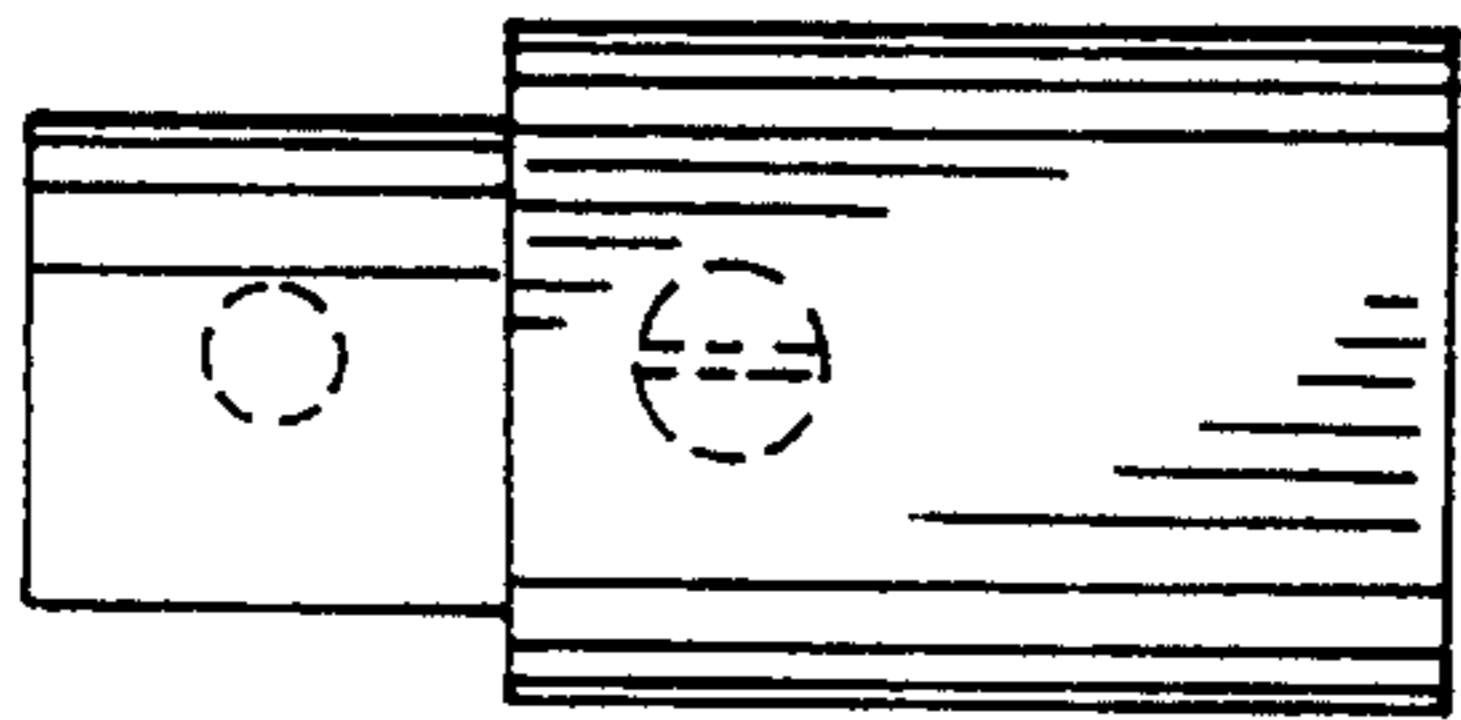

FIG. 3

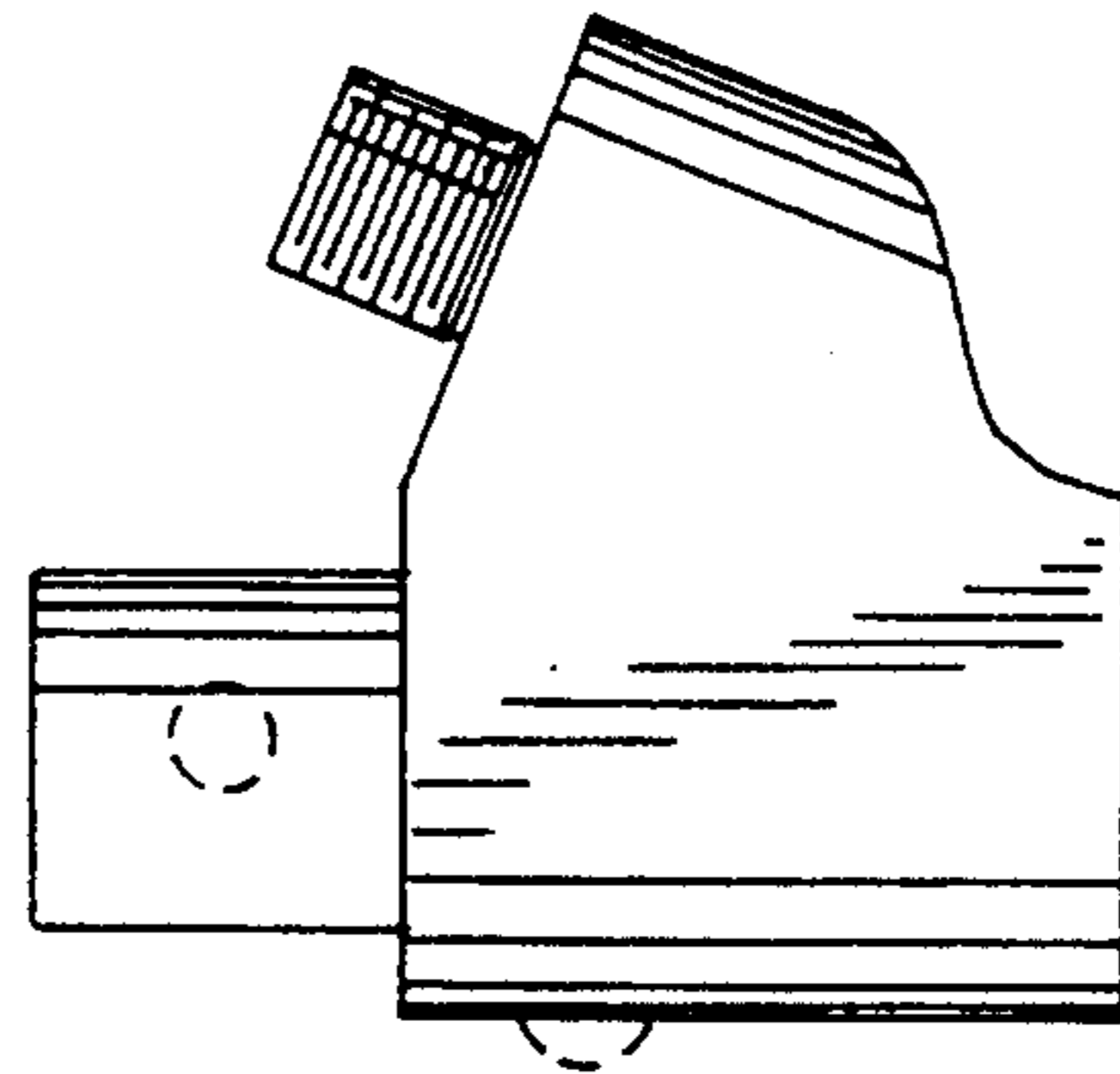

FIG. 4

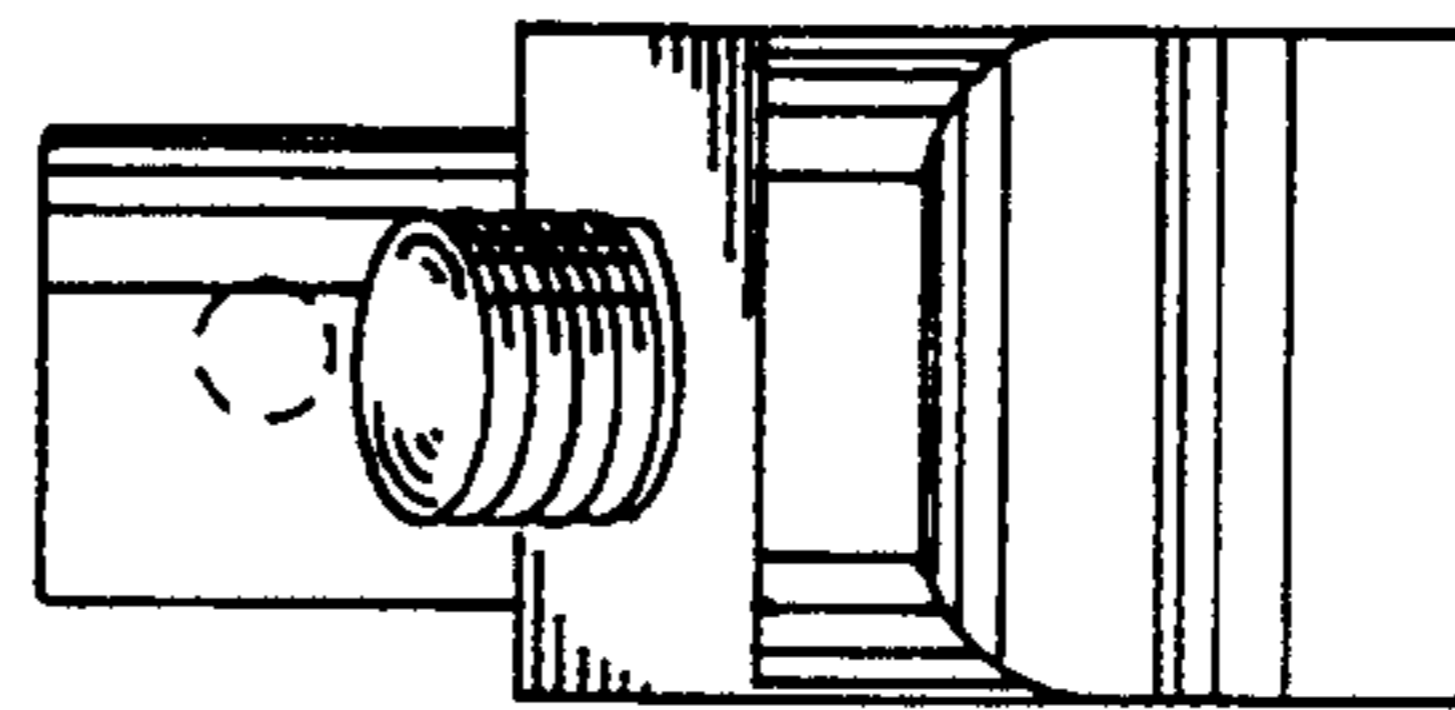

FIG. 5

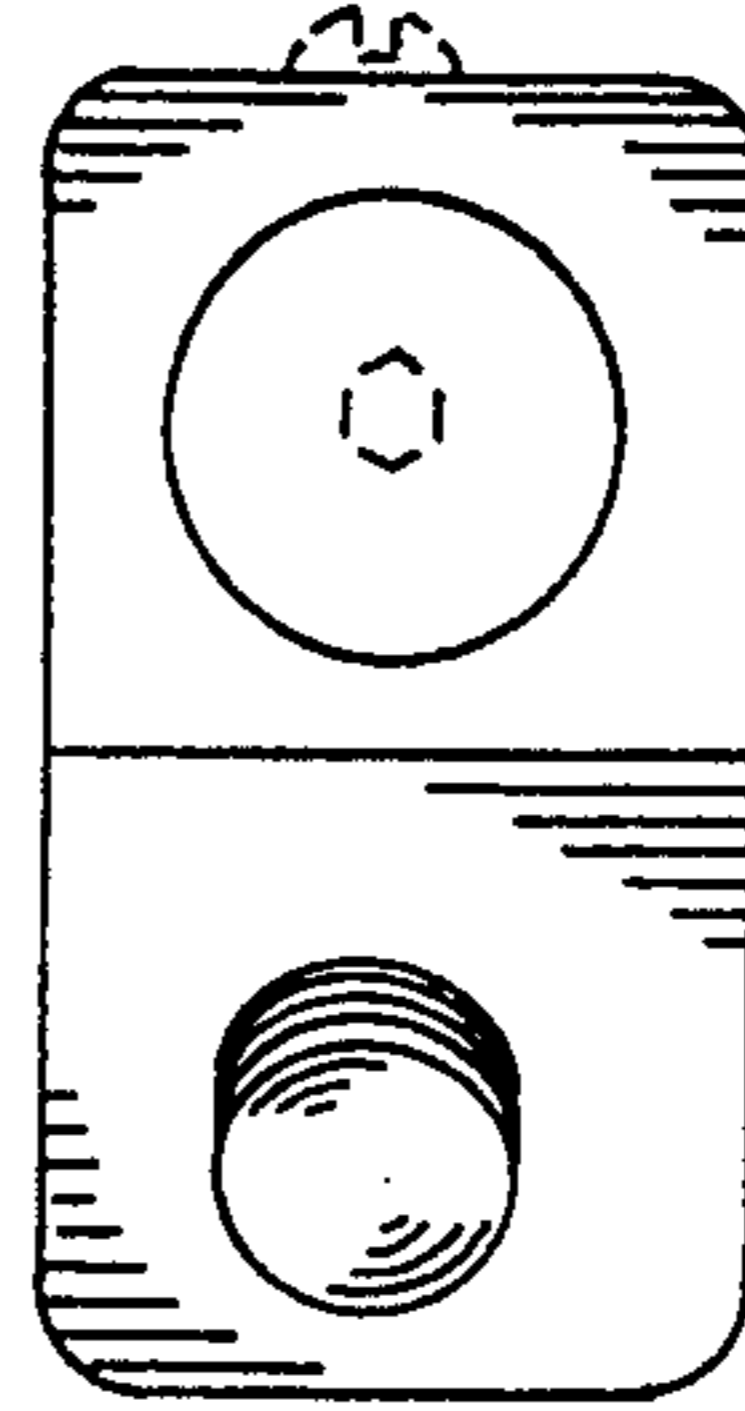

FIG. 6

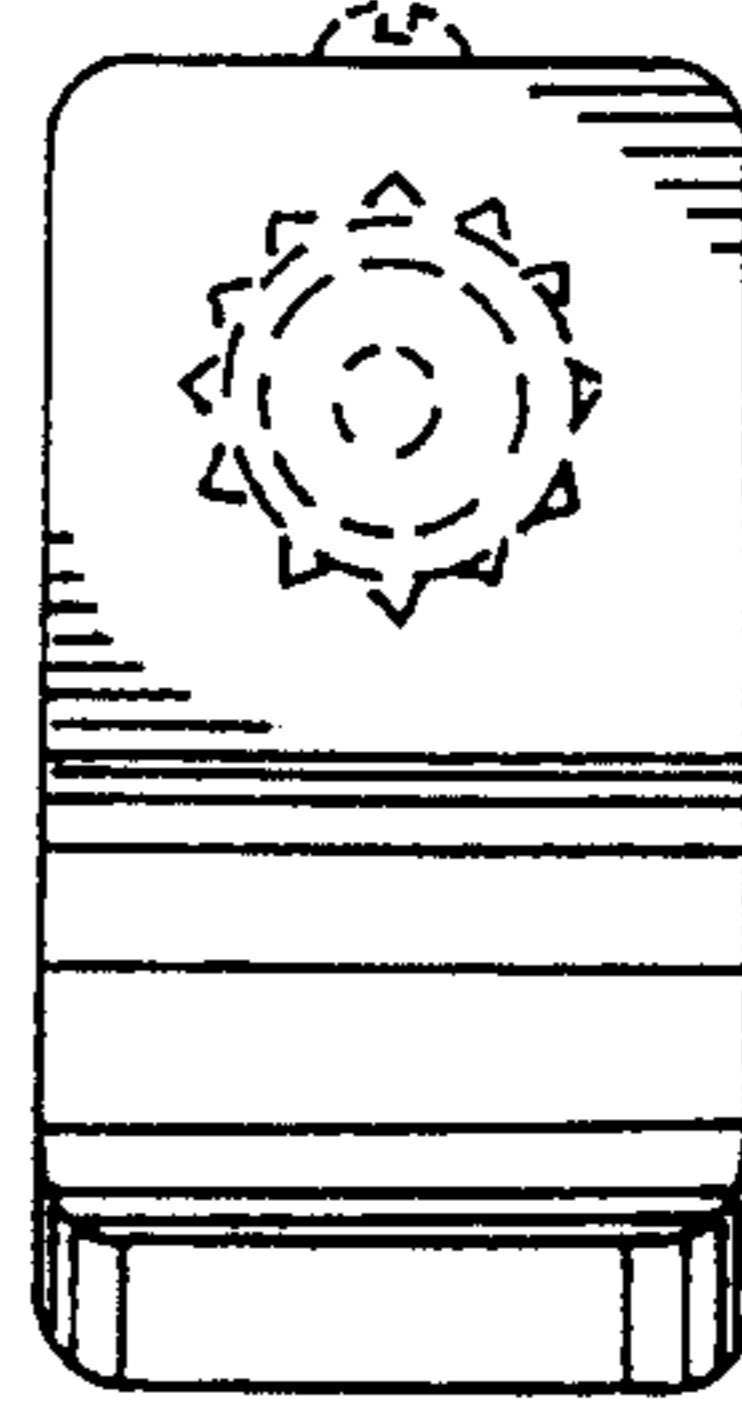

FIG. 7

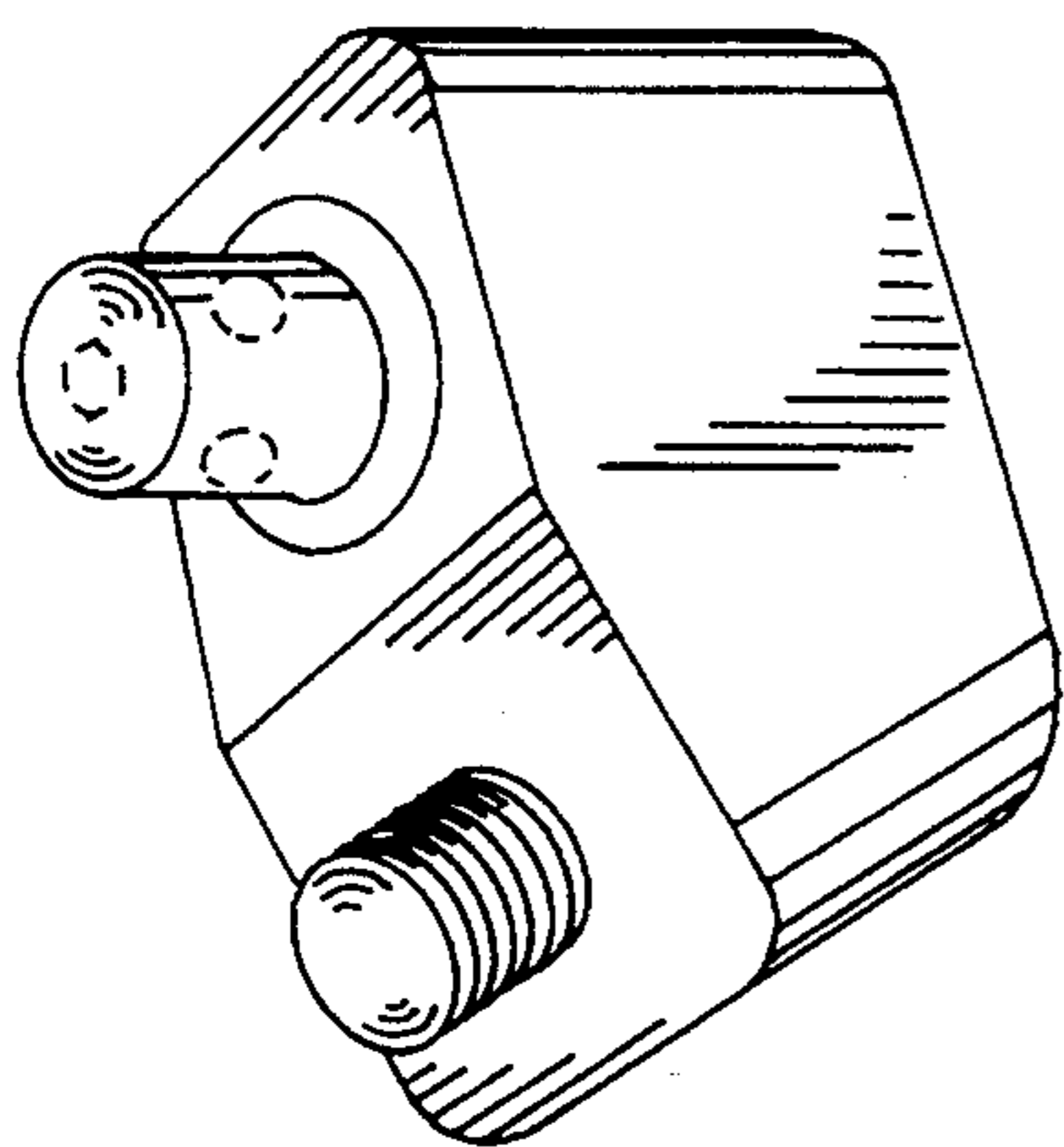

FIG. 8

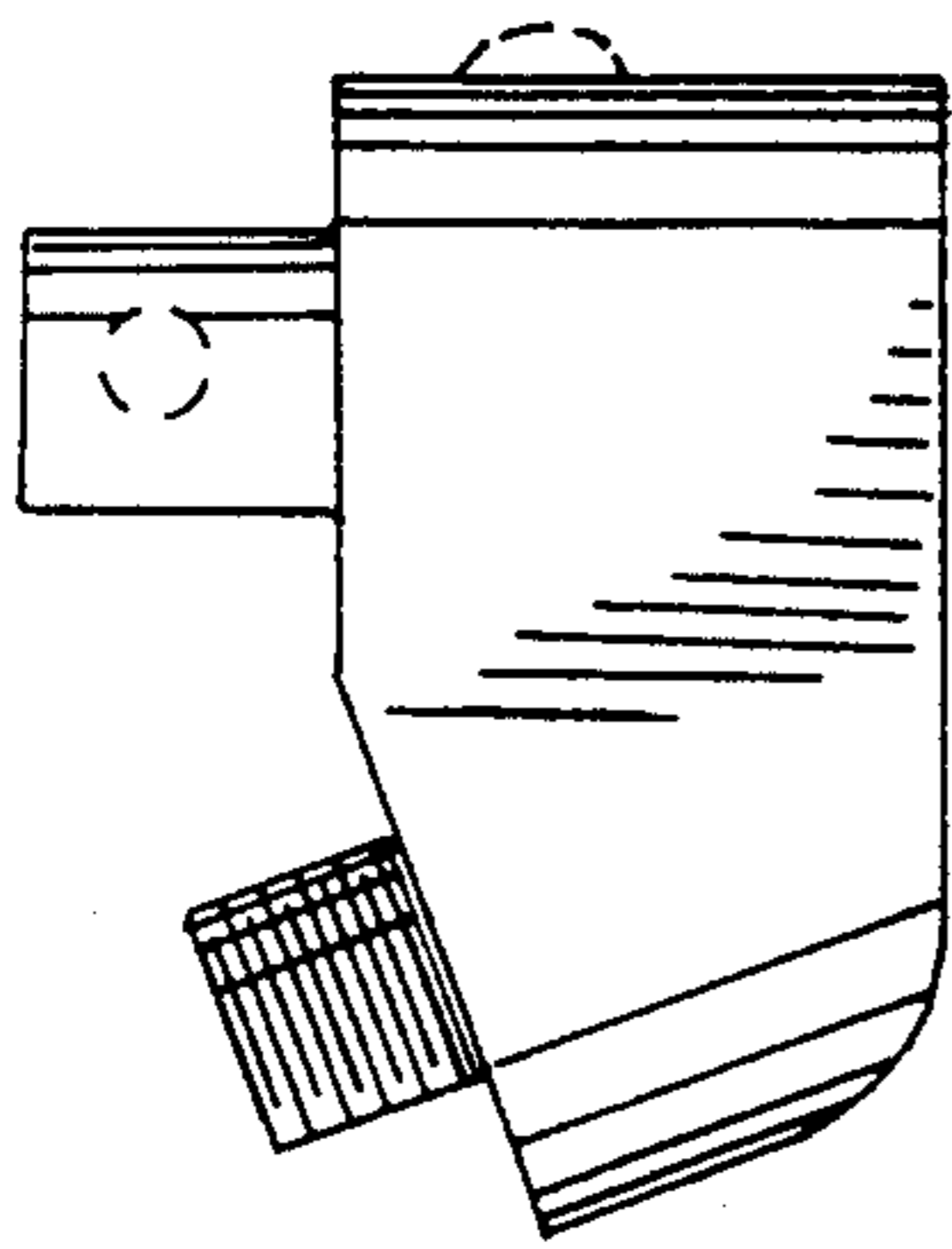

FIG. 9

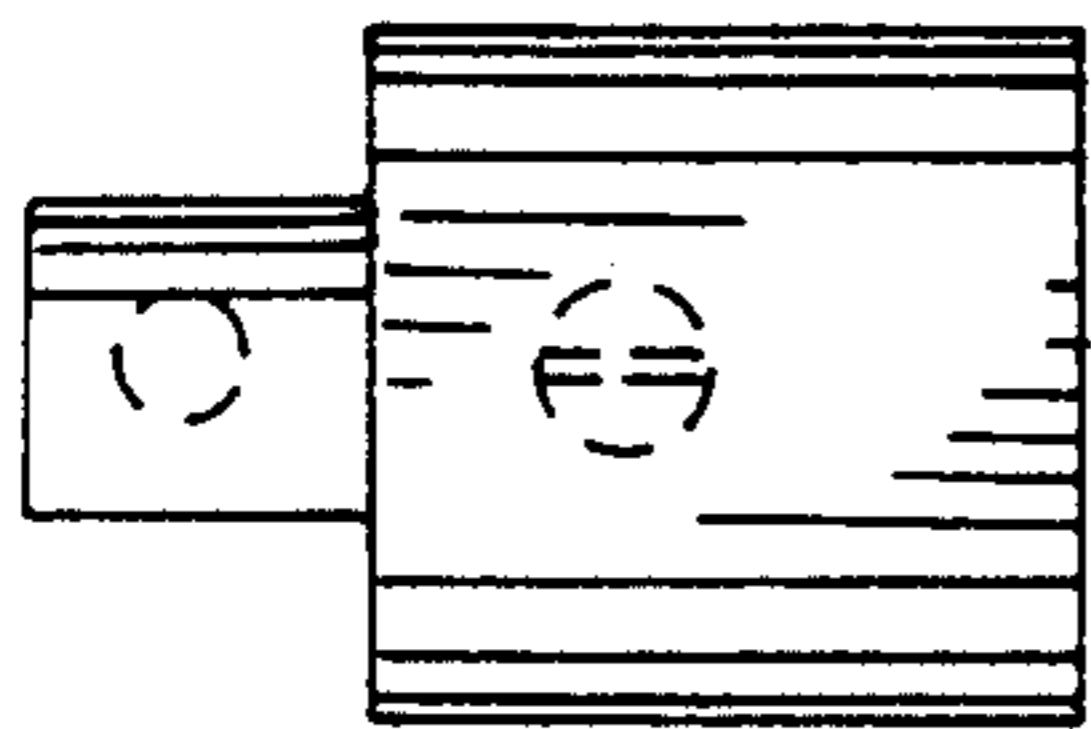

FIG. 10

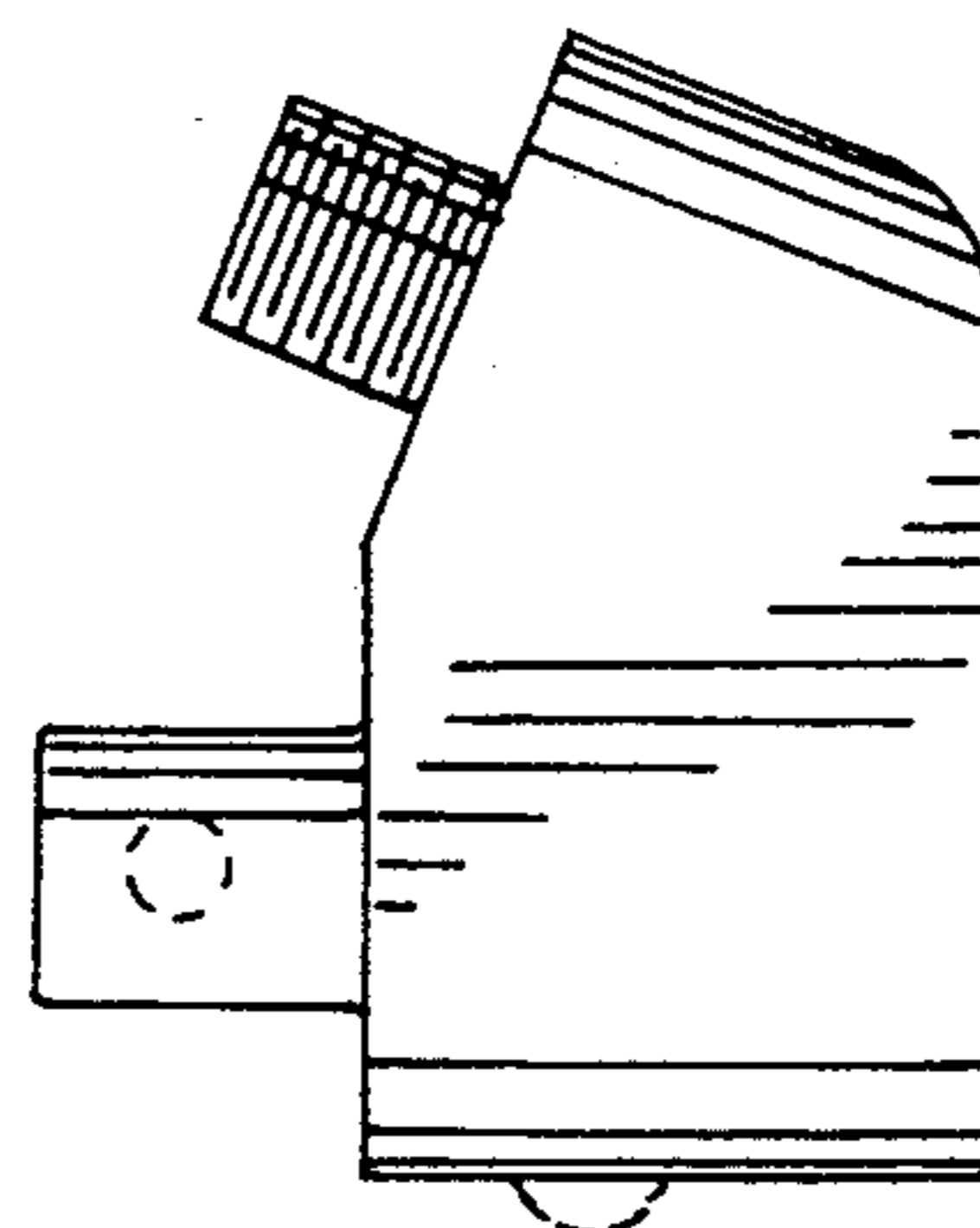

FIG. 11

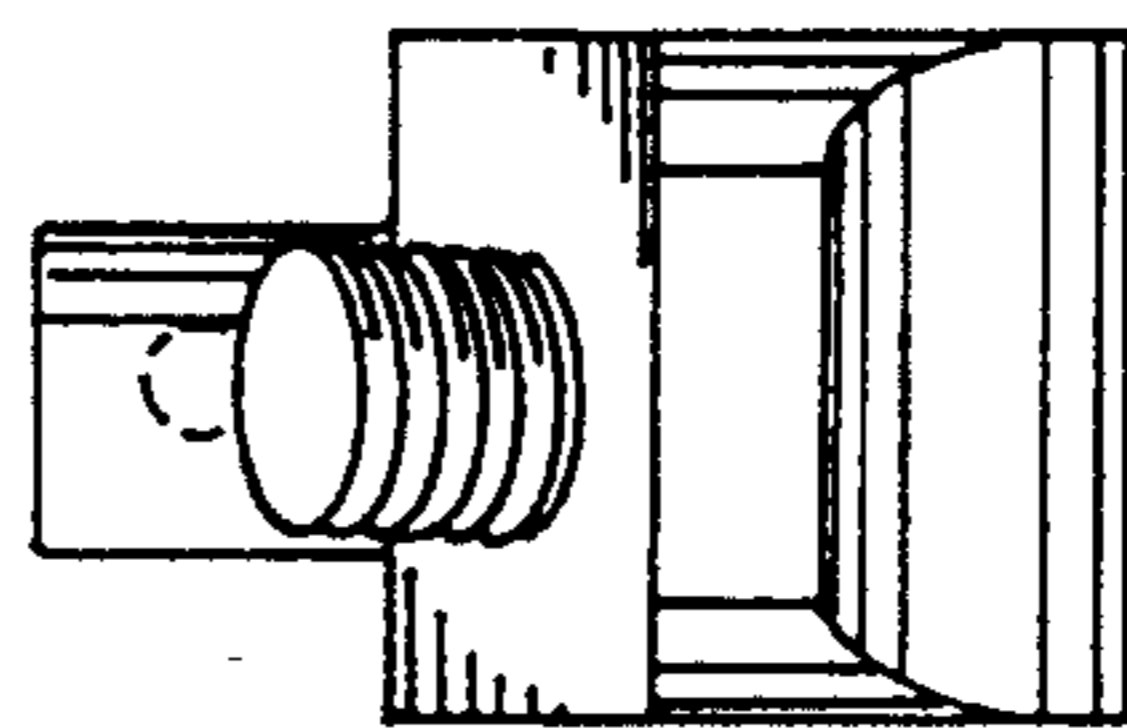

FIG. 12

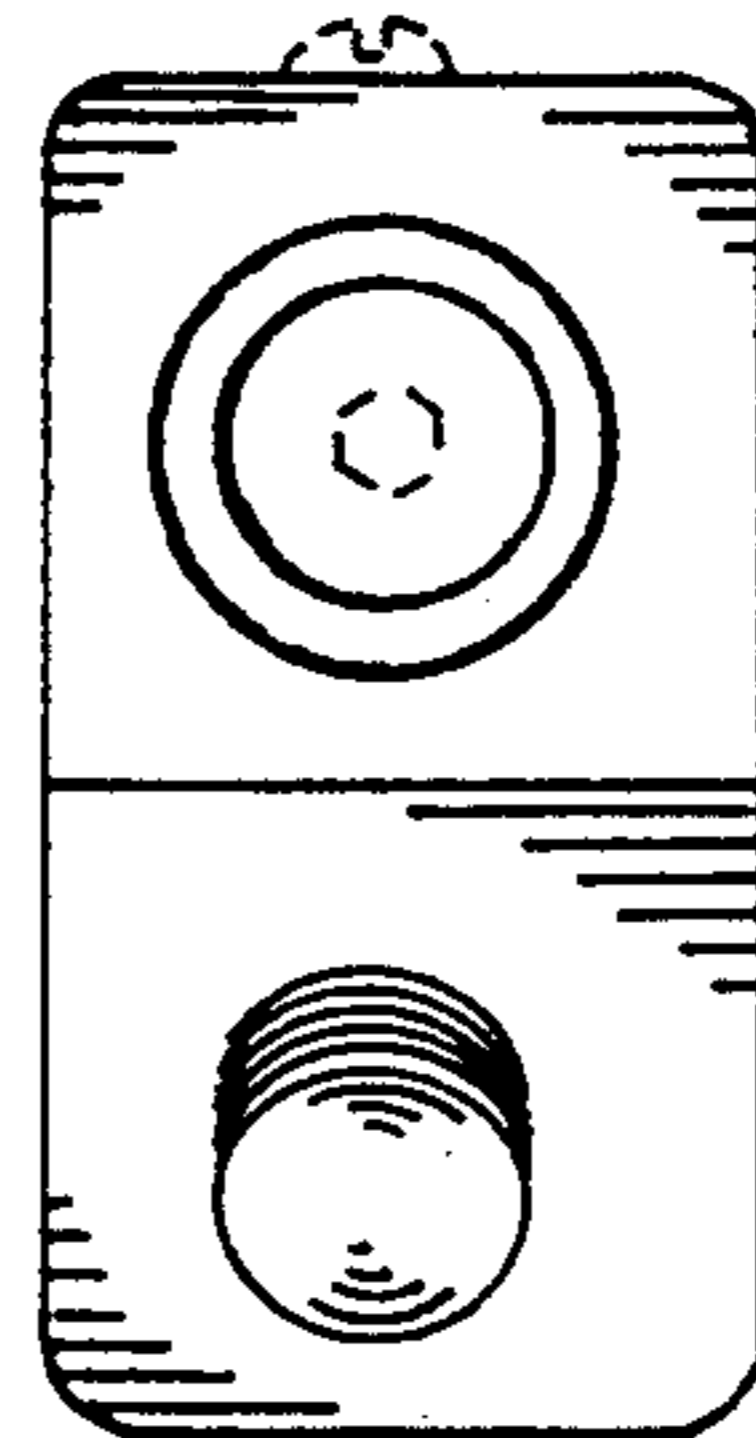

FIG. 13

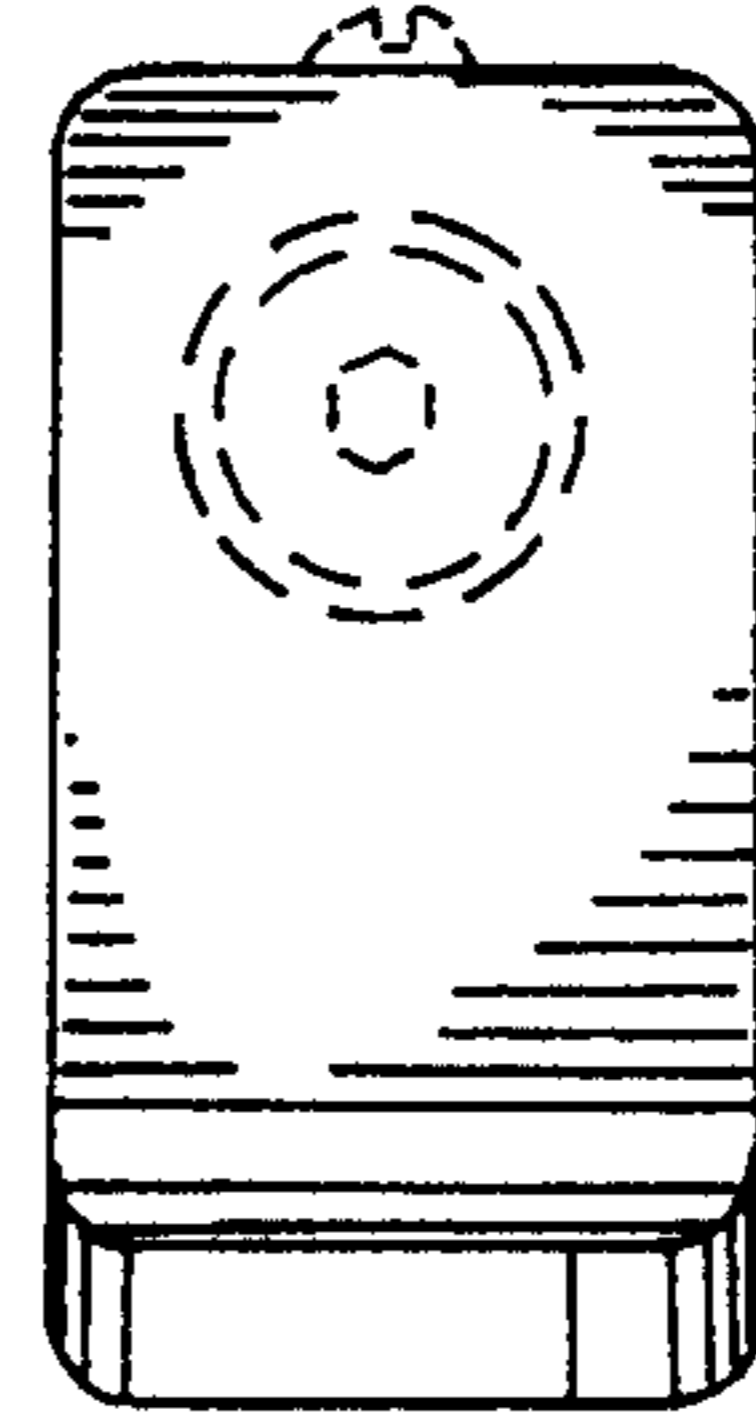

FIG. 14